

BUCKLING ASSESSMENT OF PLATED STRUCTURES

NR615 R07

EDITION JULY 2026



BUREAU VERITAS MARINE & OFFSHORE **RULE NOTE**

NR615 R07 July 2026

NR647 DT R07 July 2026 replaces the former edition July 2023.

The PDF electronic version of this document available on the Bureau Veritas Marine & Offshore website <https://marine-offshore.bureauveritas.com/> is the official version and shall prevail if there are any inconsistencies between the PDF version and any other available version.

These rules are provided within the scope of the Bureau Veritas Marine & Offshore General Conditions, enclosed at the end of Part A of NR467, Rules for the Classification of Steel Ships. The latest version of these General Conditions is available on the Bureau Veritas Marine & Offshore website.

BUREAU VERITAS MARINE & OFFSHORE

Tour Alto
4 place des Saisons
92400 Courbevoie - France
+33 (0)1 55 24 70 00

marine-offshore.bureauveritas.com/rules-guidelines

© 2026 BUREAU VERITAS - All rights reserved





RULE NOTE
NR615
BUCKLING ASSESSMENT OF
PLATED STRUCTURES

Section 1	General
Section 2	Slenderness Requirements
Section 3	Prescriptive Buckling Requirements
Section 4	Buckling Requirements for Direct Strength Analysis
Section 5	Buckling Capacity
Appendix 1	Stress Based Reference Stresses
Appendix 2	Method Selection for Direct Strength Analysis of Panels

Table of Content

Section 1	General	
1	General	4
	1.1 Application	
	1.2 Assumption	
	1.3 Scope	
2	Definitions	4
	2.1 General	
	2.2 Buckling utilisation factor	
	2.3 Allowable buckling utilisation factor	
	2.4 Buckling acceptance criteria	
Section 2	Slenderness Requirements	
1	Application	7
	1.1 General	
2	General	7
	2.1 Net thickness	
3	Stiffeners	8
	3.1 Proportions of stiffeners	
4	Primary supporting members	8
	4.1 Proportions and stiffness	
	4.2 Web stiffeners fitted on primary supporting members	
5	Brackets	9
	5.1 Tripping brackets	
	5.2 End brackets	
	5.3 Edge reinforcement	
6	Other structures	11
	6.1 Pillars	
	6.2 Edge reinforcement in way of openings	
Section 3	Prescriptive Buckling Requirements	
1	General	12
	1.1 Scope	
	1.2 Equivalent plate panel	
2	Hull girder stress	13
	2.1 General	
3	Buckling criteria	13
	3.1 Overall stiffened panels	
	3.2 Elementary plate panels	
	3.3 Stiffeners and side frames of single-side skin ships	
	3.4 Vertically corrugated longitudinal bulkheads	
	3.5 Horizontally corrugated longitudinal bulkheads	
	3.6 Struts, pillars and cross ties	
Section 4	Buckling Requirements for Direct Strength Analysis	
1	General	15
	1.1 Scope	

Table of Content

	2	Stiffened and unstiffened panels	15
	2.1	General	
	2.2	Stiffened panels	
	2.3	Unstiffened panels	
	2.4	Reference stresses	
	2.5	Lateral pressure	
	2.6	Buckling criteria	
	3	Corrugated bulkheads	18
	3.1	General	
	3.2	Reference stresses	
	3.3	Overall column buckling	
	3.4	Local buckling	
	4	Vertically stiffened side shell of single-side skin ships	20
	4.1	Buckling criteria	
	5	Struts, pillars and cross ties	20
	5.1	Buckling criteria	
Section 5		Buckling Capacity	
	1	General	22
	1.1	Scope	
	2	Buckling capacity of plates and stiffeners	23
	2.1	Overall stiffened panel capacity	
	2.2	Plate capacity	
	2.3	Stiffeners	
	2.4	Primary supporting members	
	2.5	Stiffened Panels with U-type Stiffeners	
	3	Buckling capacity of the other structures	38
	3.1	Struts, pillars and cross ties	
	3.2	Corrugated bulkheads	
Appendix 1		Stress Based Reference Stresses	
	1	Stress based method	42
	1.1	Introduction	
	1.2	Stress application	
	2	Reference stresses	42
	2.1	Regular panel	
	2.2	Irregular panel and curved panel	
Appendix 2		Method Selection for Direct Strength Analysis of Panels	
	1	Stiffened and unstiffened panels	45
	1.1	General	

Section 1 General

1 General

1.1 Application

1.1.1 This Rule Note contains the strength criteria for buckling and ultimate strength of local supporting members, primary supporting members and other structures such as pillars, corrugated bulkheads and brackets.

1.1.2 This Rule Note is to be applied for buckling of plated structures when it is referred to in the applicable Rules.

1.2 Assumption

1.2.1 For each structural member, the characteristic buckling strength is to be taken as the most unfavourable/critical buckling failure mode.

1.2.2 Unless otherwise specified, the scantling requirements of structural members in this Rule Note are based on net scantling.

1.2.3 In this Rule Note, compressive and shear stresses are to be taken as positive, tension stresses are to be taken as negative.

1.3 Scope

1.3.1 The buckling checks are to be performed according to:

- Sec 2 for the slenderness requirements of plates, longitudinal and transverse stiffeners, primary supporting members and brackets
- Sec 3 for the prescriptive buckling requirements of plates, longitudinal and transverse stiffeners, primary supporting members and other structures
- Sec 4 for the buckling requirements of the FE analysis for the plates, stiffened panels and other structures
- Sec 5 for the buckling capacity of prescriptive and FE buckling requirements.

1.3.2 Stiffeners

The buckling check of the stiffeners referred to in this Rule Note is applicable to the stiffeners fitted along the long edge of the buckling panel.

1.3.3 Enlarged stiffeners

Enlarged stiffeners used for Permanent Means of Access (PMA), whose net web height are above 700 mm, and net offered section modulus are 3 times greater than the smallest of adjacent surrounding stiffeners not used for PMA, are to comply with the following requirements:

- a) Slenderness requirements for primary supporting members as defined in Sec 2, [2.1.1]
- b) Buckling strength of prescriptive requirements:
 - for enlarged stiffener web, see Sec 3, [3.2]
 - for stiffeners fitted on enlarged stiffener web, see Sec 3, [3.1] and Sec 3, [3.3]
- c) All structural elements used for PMA are to be complied with for the buckling requirements of the FE analysis in Sec 4 when applicable.
- d) Buckling strength of longitudinal PMA platforms without stiffeners fitted on enlarged stiffener web is to be checked using the criteria for local supporting members in Sec 3, [3.1] and Sec 3, [3.3].

2 Definitions

2.1 General

2.1.1 Buckling definition

'Buckling' is used as a generic term to describe the strength of structures, generally under in-plane compressions and/or shear and lateral loads. The buckling strength or capacity can take into account the internal redistribution of loads depending on the load situation, slenderness and type of structure.

2.1.2 Buckling capacity

Buckling capacity based on this principle gives a lower bound estimate of ultimate capacity, or the maximum load the panel can carry without suffering major permanent set.

Buckling capacity assessment utilises the positive elastic post-buckling effect for plates and accounts for load redistribution between the structural components, such as between plating and stiffeners. For slender structures, the capacity calculated using this method is typically higher than the ideal elastic buckling stress (minimum Eigen value). Accepting elastic buckling of structural components in slender stiffened panels implies that large elastic deflections and reduced in-plane stiffness will occur at higher buckling utilisation levels.

2.1.3 Assessment methods

The buckling assessment is carried out according to one of the two following methods, taking into account different boundary condition types:

- Method A:
All the edges of the elementary plate panel are forced to remain straight (but free to move in the in-plane directions) due to the surrounding structure/neighbouring plates. The elementary plate is integrated in the structure, which means that it is surrounded by plates that give a strong in plane support. A typical example is a double bottom girder supporting a longitudinal bulkhead.
- Method B:
The edges of the elementary plate panel are not forced to remain straight due to low in-plane stiffness at the edges and/or no surrounding structure/neighbouring plates. The elementary plate is not surrounded by plates which means that the in-plane support is weak. A typical example is a double bottom girder not supporting a longitudinal bulkhead.

2.2 Buckling utilisation factor

2.2.1 The utilisation factor η is defined as the ratio between the applied loads and the corresponding ultimate capacity or buckling strength.

2.2.2 For combined loads, the utilisation factor η_{act} is to be defined as the ratio of the applied equivalent stress and the corresponding buckling capacity, as shown in Fig 1, and is to be taken as:

$$\eta_{act} = \frac{W_{act}}{W_u} = \frac{1}{\gamma_c}$$

where:

- W_{act} : Equivalent applied stress (see Fig 1)
- W_u : Equivalent buckling capacity (see Fig 1)
- γ_c : Stress multiplier factor at failure as calculated in Sec 5.

For each typical failure mode, the corresponding capacity of the panel is calculated by applying the actual stress combination and then increasing or decreasing the stresses proportionally until collapse.

Fig 1 illustrates the buckling capacity and the buckling utilisation factor of a structural member subjected to σ_x and σ_y stresses. where:

- σ_x, σ_y : Membrane stresses, in N/mm², applied, respectively, in x direction and in y direction.

Figure 1 : Example of buckling capacity and buckling utilisation factor

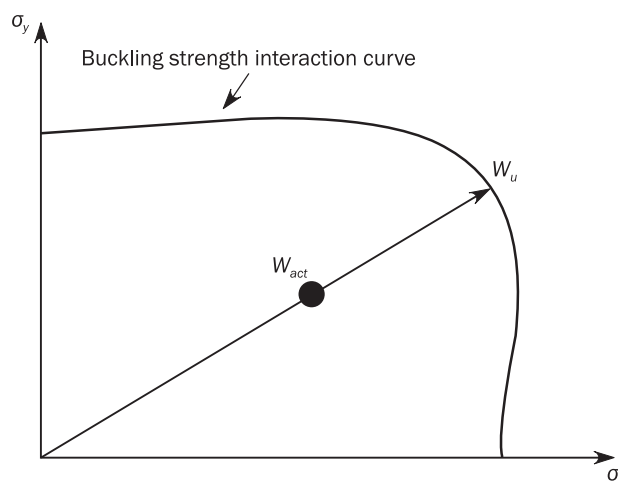

2.3 Allowable buckling utilisation factor

2.3.1 General structural elements

The allowable buckling utilisation factor η_{all} is defined in the applicable Rules.

2.4 Buckling acceptance criteria

2.4.1 A structural member is considered to have an acceptable buckling strength when it satisfies the following criterion:

$$\eta_{act} \leq \eta_{all}$$

where:

- η_{act} : Buckling utilisation factor based on the applied stress, defined in [2.2.2]
- η_{all} : Allowable buckling utilisation factor as defined in [2.3].

Section 2 Slenderness Requirements

Symbols

b_{f-out}	: Maximum distance, in mm, from mid-thickness of the web to the flange edge, as shown in Fig 1
ℓ	: Span of stiffeners, in m
s	: Stiffener spacing, in mm
h_w	: Depth of stiffener web, in mm, as shown in Fig 1
R_{eH}	: Specified minimum yield stress, in N/mm ²
ℓ_b	: Effective length of bracket edge, in mm, as defined in Tab 2
s_{eff}	: Effective width of stiffener attached plating, in mm, taken equal to: $s_{eff} = 0,8 s$.

1 Application

1.1 General

1.1.1 All the structural elements are to comply with the applicable slenderness and proportion requirements given in Article [2] to Article [6] except for the ones listed below:

- bilge plates within the cylindrical part of the ship and radiused gunwale
- corrugation
- structural members in superstructures and deck houses, not contributing to the longitudinal strength.

1.1.2 Materials

The requirements of this Section apply to structures made of steel materials. Structures made of aluminium materials are to comply with the requirements given in NR561, Appendix 2.

2 General

2.1 Net thickness

2.1.1 The net thickness t , in mm, of plate panels, stiffeners and primary supporting members webs and flanges and of pillars is to satisfy the following criteria:

$$t \geq 2,32 \cdot b \cdot 10^{-3} \cdot \sqrt{\frac{\sigma_{Et}}{K}}$$

where:

b : Breadth of the unstiffened part of the considered panel, in mm, to be taken equal to s , h_w or b_{f-out} , as applicable

K : Boundary condition factor, taken equal to:

- for plate panels, for webs of T bars, angle bars, primary supporting members and I-section pillars and for walls of box section pillars:
 $K = 4$
- for webs of bulb flats:
 $K = 1,25$
- for webs of flat bars and for all types of flanges (including those of I-section pillars):
 $K = 0,43$

σ_{Et} : Targeted Euler buckling stress, taken equal to:

- for $\sigma_{ct} \leq 0,5 R_{eH}$:
 $\sigma_{Et} = \sigma_{ct}$
- for $\sigma_{ct} > 0,5 R_{eH}$:

$$\sigma_{Et} = \frac{R_{eH}}{4 - \frac{4 \cdot \sigma_{ct}}{R_{eH}}}$$

σ_{ct} : Targeted critical buckling stress, taken equal to:

- for stiffened plate panels and stiffened webs of primary supporting members:
 $\sigma_{ct} = 0,2 R_{eH}$

- for webs of stiffeners and unstiffened webs of primary supporting members:
 $\sigma_{ct} = 0,5 R_{eH}$
- for flanges and pillars:
 $\sigma_{ct} = 0,9 R_{eH}$

Without being taken greater than the maximum compressive stress applied on the small side of the plate panel induced by the combined effect of hull girder and local loads, if known and as calculated according to the applicable Rules.

3 Stiffeners

3.1 Proportions of stiffeners

3.1.1 Flange breadth

The total flange breadth b_f , in mm, for angle bars, T-bars, L2 bars and I-section pillars is to satisfy the following criterion: $b_f \geq 0,2 h_w$.

Figure 1 : Stiffener scantling parameters

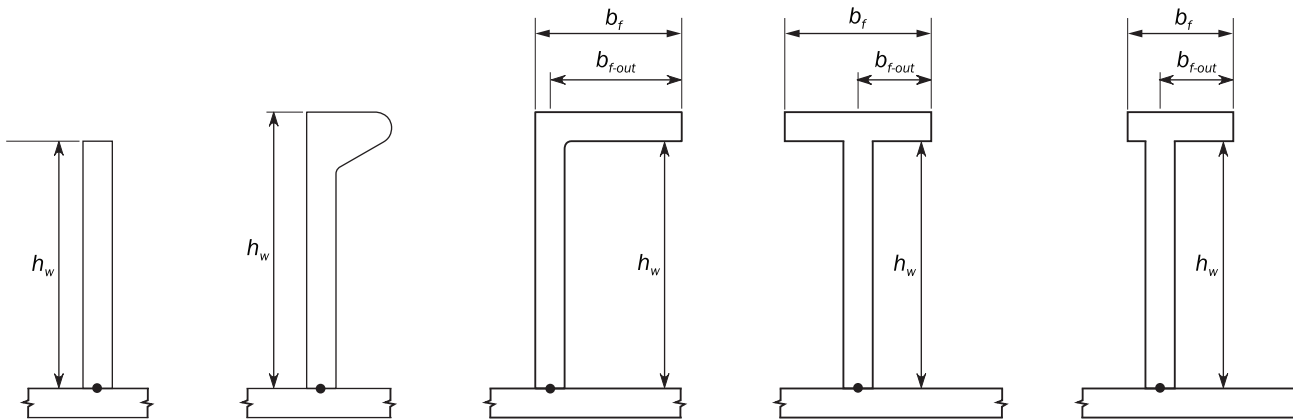

4 Primary supporting members

4.1 Proportions and stiffness

4.1.1 Stiffness of deck transverse primary supporting members

The net moment of inertia $I_{psm-n50}$, in cm^4 , of deck transverse primary members supporting deck longitudinals subject to axial compressive hull girder stress is to comply, within the central half of the bending span, with the following criterion:

$$I_{psm-n50} \geq 300 \frac{\ell_{bdg}^4}{S^3 S} I_{st}$$

where:

$I_{psm-n50}$: Net moment of inertia, in cm^4 , of deck transverse primary supporting members with an effective width of attached plating equal to $0,8 S$

ℓ_{bdg} : Effective bending span of deck transverse primary supporting members, in m, as defined in the applicable Rules

S : Spacing of deck transverse primary supporting members, in m, as defined in the applicable Rules

I_{st} : Net moment of inertia of deck stiffeners, in cm^4 , within the central half of the bending span, taken equal to:

$$I_{st} = 1,43 \ell^2 A_{eff} \frac{R_{eH}}{235}$$

A_{eff} : Net sectional area of the stiffener, including its effective attached plating s_{eff} , in cm^2

R_{eH} : Specified minimum yield stress of the material of the stiffener attached plating, in N/mm^2 .

4.2 Web stiffeners fitted on primary supporting members

4.2.1 Proportions of web stiffeners

The net thicknesses (web plate and flange) and dimensions of the web stiffeners fitted on primary supporting members are to satisfy the requirements specified in [3.1.1].

4.2.2 Stiffness of web stiffeners

The net moment of inertia I_{st} , in cm^4 , of web stiffeners fitted on primary supporting members, with effective attached plating s_{eff} , is not to be less than the minimum moment of inertia defined in Tab 1.

Table 1 : Stiffness criteria for web stiffeners fitted on primary supporting members (PSM)

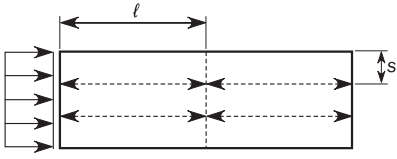
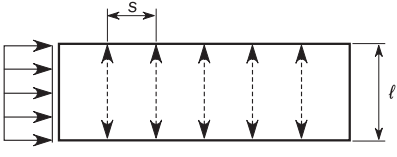
Stiffener arrangement		Minimum moment of inertia of web stiffeners, in cm ⁴
A	 <p>Web stiffeners fitted along the PSM span</p>	$I_{st} \geq 0,72 \ell^2 A_{eff} \frac{R_{eH}}{235}$
B	 <p>Web stiffeners fitted normal to the PSM span</p>	$I_{st} \geq 1,14 \ell s^2 t_w \left(2,5 \frac{1000 \ell}{s} - 2 \frac{s}{1000 \ell} \right) \frac{R_{eH}}{235} 10^{-5}$

Note 1: ℓ : Length of the web stiffeners, in m:

- for web stiffeners welded to local supporting members, the length is to be measured between the flanges of the local support members
- for sniped web stiffeners, the length is to be measured between the lateral supports, i.e. corresponds to the total distance between the flanges of the primary supporting member, as shown for stiffener arrangement B

Note 2: A_{eff} : Net sectional area, in cm², of the web stiffener, including its effective attached plating s_{eff}

t_w : Net web thickness of the primary supporting member, in mm

R_{eH} : Specified minimum yield stress of the material of the web plate of the primary supporting member, in N/mm².

5 Brackets

5.1 Tripping brackets

5.1.1 Distance between tripping brackets

The distance between tripping brackets, in m, is to satisfy the following criterion:

$$S_b \leq \text{Max} \left(b_f C \sqrt{\frac{A_{f-n50}}{A_{f-n50} + \frac{A_{w-n50}}{3}}} \left(\frac{235}{R_{eH}} \right) ; S_{b-\text{min}} \right)$$

where:

b_f : Flange breadth of primary supporting members, in mm

C : Slenderness coefficient taken as:

- $C = 0,022$ for symmetrical flanges
- $C = 0,033$ for asymmetrical flanges

A_{f-n50} : Net cross-sectional area of the flange, in cm²

A_{w-n50} : Net cross-sectional area of the web plate, in cm²

R_{eH} : Specified minimum yield stress of the primary supporting member (PSM) material, in N/mm²

A lower specified minimum yield stress may be used in this slenderness criterion provided the buckling requirements specified in Sec 3 and Sec 4 and the yielding requirements of the applicable Rules are satisfied considering the PSM is made of a material with the same lower specified minimum yield stress.

$S_{b-\text{min}}$: Minimum distance between tripping brackets, in m, taken as:

- $S_{b-\text{min}} = 3,0$ m for tank/hold boundaries or hull envelope including external decks
- $S_{b-\text{min}} = 4,0$ m for the other areas.

5.1.2 Edge stiffening

The tripping brackets on primary supporting members are to be stiffened by a flange or an edge stiffener if the effective length of the edge ℓ_b , as defined in Tab 2, in mm, is greater than $75 t_b$, where:

t_b : Net web thickness of the brackets, in mm.

5.2 End brackets

5.2.1 Proportions

The net web thickness, in mm, of the end brackets subjected to compressive stresses is to satisfy the following criterion:

$$t_b \geq \frac{d_b}{C} \sqrt{\frac{R_{eH}}{235}}$$

where:

- d_b : Bracket depth, in mm, as defined in Tab 2
- C : Slenderness coefficient as defined in Tab 2
- R_{eH} : Specified minimum yield stress of the end bracket material, in N/mm².

Table 2 : Slenderness coefficient C for proportions of brackets

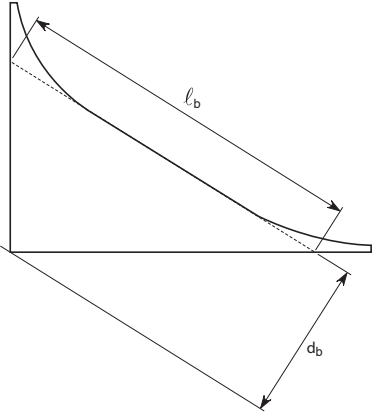
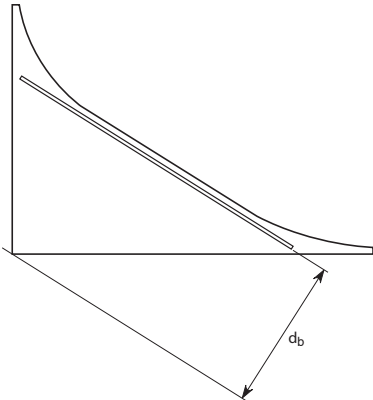
Mode	C
<p style="text-align: center;">Brackets without edge stiffener</p> 	$C = 20 \left(\frac{d_b}{l_b} \right) + 16$ <p style="text-align: center;">with:</p> $0,25 \leq \frac{d_b}{l_b} \leq 1,0$
<p style="text-align: center;">Brackets with edge stiffener</p> 	$C = 70$

5.3 Edge reinforcement

5.3.1 Reinforcement of bracket edges

The web depth h_w , in mm, of the edge stiffeners in way of brackets is to satisfy the following criterion:

$$h_w \geq \text{Max} \left(C l_b \sqrt{\frac{R_{eH}}{235}} \cdot 10^{-3}; 50 \right)$$

where:

- C : Slenderness coefficient, taken as:
 - $C = 75$ for end brackets
 - $C = 50$ for tripping brackets
- R_{eH} : Specified minimum yield stress of the stiffener material, in N/mm².

5.3.2 Proportions of edge stiffeners

The net thicknesses (web plate and flange) and dimensions of the edge stiffeners are to satisfy the requirements specified in [3.1.1] and [3.1.1].

6 Other structures

6.1 Pillars

6.1.1 Proportions of I-section pillars

The net thicknesses (web plate and flanges) and dimensions of I-section pillars are to comply with the requirements specified in [2.1.1] and [3.1.1].

6.1.2 Proportions of box section pillars

The net thickness of thin-walled box section pillars is to comply with the requirements specified in [3.1.1].

6.1.3 Proportions of circular section pillars

The net thickness t , in mm, of circular section pillars is to comply with the following criterion:

$$t \geq \frac{r}{50}$$

where:

r : Mid-thickness radius of the circular section, in mm.

6.2 Edge reinforcement in way of openings

6.2.1 Depth of edge stiffeners

When fitted as shown in Fig 2, the web depth h_w , in mm, of edge stiffeners in way of openings is to satisfy the following criterion:

$$h_w \geq \text{Max} \left(C \ell \sqrt{\frac{R_{eH}}{235}} ; 50 \right)$$

where:

C : Slenderness coefficient taken as: $C = 50$

R_{eH} : Specified minimum yield stress of the edge stiffener material, in N/mm²

ℓ : Length of edge stiffener in way of opening, in m, as defined in Fig 2.

6.2.2 Proportions of edge stiffeners

The net thicknesses (web plate and flange) and dimensions of the edge stiffeners are to satisfy the requirements specified in [2.1.1] and [3.1.1].

Figure 2 : Typical edge reinforcements

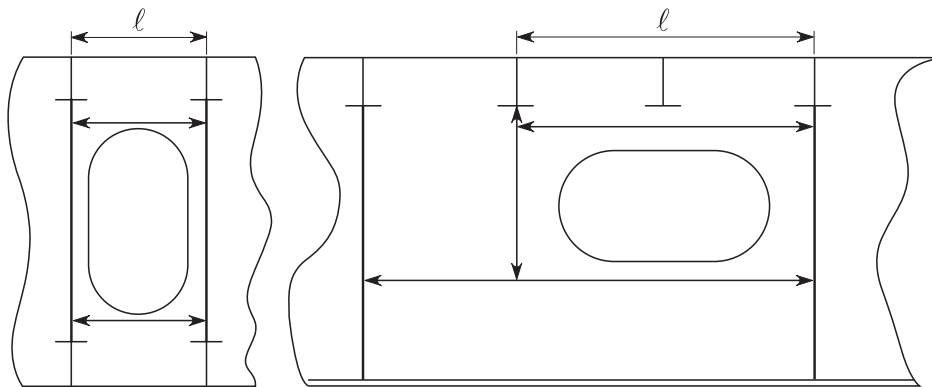

Section 3 Prescriptive Buckling Requirements

Symbols

- η_{all} : Allowable buckling utilisation factor, as defined in Sec 1, [2.3]
 EPP : Elementary Plate Panel, i.e. the unstiffened part of the plating between stiffeners and/or primary supporting members
 LCP : Load Calculation Point, as defined in the applicable Rules.

1 General

1.1 Scope

1.1.1 This Section applies to plate panels, including curved plate panels, and stiffeners subject to hull girder compression and shear stresses. In addition the following structural members subject to compressive stresses are to be checked:

- corrugations of longitudinal corrugated bulkheads
- struts
- pillars
- cross ties.

1.1.2 The hull girder buckling strength requirements apply along the full length of the ship.

1.1.3 Design load sets

The buckling checks are to be performed for all design load sets, with pressure combination defined in the applicable Rules.

For each design load set, and for all dynamic load cases, the lateral pressure is to be determined and applied at a load calculation point as described in the applicable Rules. It is to be applied together with the hull girder stress combinations given in [2.1].

1.2 Equivalent plate panel

1.2.1 In longitudinal stiffening arrangement, when the plate thickness varies over the width b of a plate panel, the buckling check is to be performed for an equivalent plate panel width, combined with the smaller plate thickness t_1 . The width b_{eq} of this equivalent plate panel, in mm, is defined by the following formula:

$$b_{eq} = \ell_1 + \ell_2 \left(\frac{t_1}{t_2} \right)^{1.5}$$

where:

- ℓ_1 : Width of the part of the plate panel with the smaller net plate thickness t_1 , in mm, as defined in Fig 1
 ℓ_2 : Width of the part of the plate panel with the greater net plate thickness t_2 , in mm, as defined in Fig 1.

1.2.2 In transverse stiffening arrangement, when an EPP is made with different thicknesses, the buckling check of the plate and stiffeners is to be made for each thickness considered constant on the EPP, the stresses and pressures being estimated for the EPP at the LCP.

1.2.3 Materials

When the plate panel is made of different materials, the minimum yield strength is to be used for the buckling assessment.

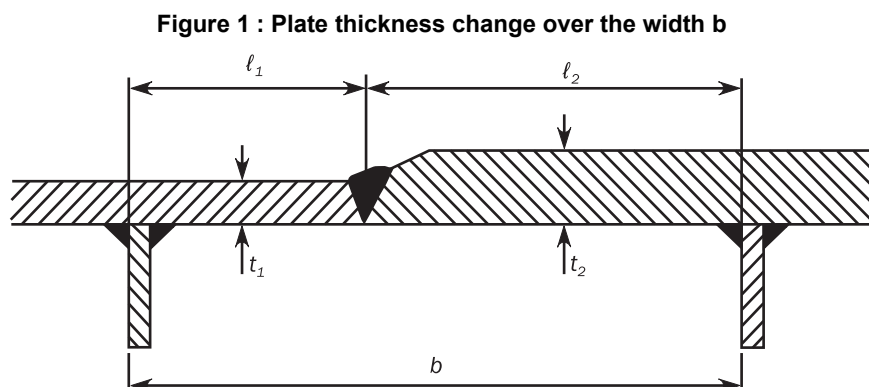

2 Hull girder stress

2.1 General

2.1.1 Each elementary plate panel and each stiffener are to satisfy the criteria defined in [3] with the following stress combinations:

a) Longitudinal stiffening arrangement:

$$\sigma_x = \sigma_{hg}$$

$$\sigma_y = 0$$

$$\tau = \tau_{hg}$$

b) Transverse stiffening arrangement:

$$\sigma_x = 0$$

$$\sigma_y = \sigma_{hg}$$

$$\tau = \tau_{hg}$$

where:

σ_{hg} : Hull girder bending stress, in N/mm², in the elementary plate panel or in the stiffener, determined according to the applicable Rules

τ_{hg} : Hull girder shear stress, in N/mm², in the elementary plate panel or in the stiffener attached plating, determined according to the applicable Rules.

3 Buckling criteria

3.1 Overall stiffened panels

3.1.1 The buckling strength of overall stiffened panels is to satisfy the following criterion:

$$\eta_{Overall} \leq \eta_{all}$$

where:

$\eta_{Overall}$: Maximum utilisation factor, as defined in Sec 5, [2.1].

3.2 Elementary plate panels

3.2.1 The buckling strength of elementary plate panels is to satisfy the following criterion:

$$\eta_{Plate} \leq \eta_{all}$$

where:

η_{Plate} : Maximum plate utilisation factor calculated according to SP-A, as defined in Sec 5, [2.2].

For the determination of η_{Plate} of the vertically stiffened side shell plating of single side skin ships between hopper and topside tanks, the cases 12 and 16 of Sec 5, Tab 4 corresponding to the shorter edge of the plate panel clamped are to be considered together with a mean σ_y stress and $\psi_y = 1$.

3.3 Stiffeners and side frames of single-side skin ships

3.3.1 The buckling strength of stiffeners or of side frames of single-side skin ships between hopper and topside tanks is to satisfy the following criterion:

$$\eta_{Stiffener} \leq \eta_{all}$$

where:

$\eta_{Stiffener}$: Maximum stiffener utilisation factor, as defined in Sec 5, [2.3].

Note 1: This criterion check can only be fulfilled when the overall stiffened panel criterion, as defined in [3.1.1], is satisfied.

Note 2: The buckling check of the stiffeners is only applicable to the stiffeners fitted along the long edge of the buckling panel.

3.4 Vertically corrugated longitudinal bulkheads

3.4.1 The shear buckling strength of vertically corrugated longitudinal bulkheads is to satisfy the following criterion:

$$\eta_{\text{Shear}} \leq \eta_{\text{all}}$$

where:

η_{Shear} : Maximum shear corrugated bulkhead utilisation factor:

$$\eta_{\text{Shear}} = \frac{\tau_{\text{bhd}}}{\tau_c}$$

τ_{bhd} : Hull girder shear stress, in N/mm², in the longitudinal bulkhead as defined in Article [2]

τ_c : Shear critical stress, in N/mm², as defined in Sec 5, [2.2.3].

3.5 Horizontally corrugated longitudinal bulkheads

3.5.1 Each corrugation, within the extension of half flange, web and half flange (i.e. single corrugation as shown in grey in Fig 2, is to satisfy the following criterion:

$$\eta \leq \eta_{\text{all}}$$

where:

η : Overall column utilisation factor, as defined in Sec 5, [3.1].

Figure 2 : Single corrugation

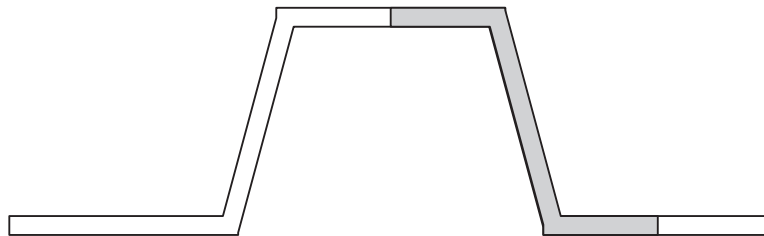

3.6 Struts, pillars and cross ties

3.6.1 The compressive buckling strength of struts, pillars and cross ties is to satisfy the following criterion:

$$\eta \leq \eta_{\text{all}}$$

where:

η : Maximum buckling utilisation factor of struts, pillars or cross ties, as defined in Sec 5, [3.1].

3.6.2 The buckling strength of pillars subject to axial force and bending moments may be required to be checked based on direct calculations. The buckling criterion is to be especially considered by the Society.

Section 4 Buckling Requirements for Direct Strength Analysis

Symbols

- η_{all} : Allowable buckling utilisation factor, as defined in Sec 1, [2.3]
 α : Aspect ratio of the plate panel, defined in Sec 5.

1 General

1.1 Scope

1.1.1 The requirements of this Section apply for the buckling assessment of direct strength analysis subjected to compressive stress, shear stress and lateral pressure.

1.1.2 All structural elements in the FE analysis are to be assessed individually. The buckling checks are to be performed for the following structural elements:

- stiffened and unstiffened panels, including curved panels
- web plates in way of openings
- corrugated bulkheads
- vertically stiffened side shell, between hopper and topside tanks, of single-side skin ships
- struts, pillars and cross ties.

2 Stiffened and unstiffened panels

2.1 General

2.1.1 The plate panels of hull structure are to be modelled as stiffened or unstiffened panels. Method A or Method B as defined in Sec 1, [2] is to be used according to App 2.

2.1.2 Average thickness of plate panel

Where the plate thickness along a plate panel is not constant, the panel used for the buckling assessment is to be modelled according to the applicable Rules, with a weighted average thickness t_{avr} , in mm, taken as:

$$t_{avr} = \frac{\sum_{i=1}^n A_i t_i}{\sum_{i=1}^n A_i}$$

where:

- A_i : Area of the i -th plate element, in mm^2
 t_i : Net thickness of the i -th plate element, in mm
 n : Number of finite elements defining the buckling plate panel.

2.1.3 Yield stress of plate panel

The yield stress $R_{eH,P}$, in N/mm^2 , of a plate panel is taken as the minimum value of the specified yield stresses of the elements within the plate panel.

2.2 Stiffened panels

2.2.1 To represent the overall buckling behaviour, each stiffener with attached plating is to be modelled as a stiffened panel of the extent defined in App 2, Tab 1.

2.2.2 If the stiffener properties or the stiffener spacing vary within the stiffened panel, the calculations are to be performed separately for all the configurations of the plate panels, i.e. for each stiffener and plate between the stiffeners. The plate thickness, stiffener properties and stiffener spacing at the considered location are to be assumed for the whole panel.

2.2.3 The buckling check of the stiffeners of stiffened panels is only applicable to the stiffeners fitted along the longer side edges of the buckling panel.

2.3 Unstiffened panels

2.3.1 Irregular panel

In way of web frames, stringers and brackets, the geometry of the panel (i.e. plate bounded by web stiffeners/face plates) may not have a rectangular shape. In this case, an equivalent rectangular panel is to be defined according to [2.3.2] for irregular geometry and [2.3.3] for triangular geometry and is to comply with buckling assessment.

2.3.2 Modelling of an unstiffened panel with irregular geometry

Unstiffened panels with irregular geometry are to be idealised to equivalent rectangular panels for plate buckling assessment according to the following procedure:

- a) The four corners closest to a right angle (90 deg) in the bounding polygon for the plate are identified as shown in Fig 1a).
- b) The distances along the plate bounding polygon between the corners (as shown in Fig 1, b) are calculated, i.e. the sum of all the straight line segments between the end points.
- c) The pair of opposite edges with the smallest total length is identified, i.e. the minimum of $(d_1 + d_3)$ and $(d_2 + d_4)$
- d) A line joins the middle points of the chosen opposite edges as shown in Fig 1 c) (a middle point is defined as the point at half the distance from one end). This line defines the longitudinal direction for the capacity model. The length of the line defines the length a of the capacity model, measured from one end point.
- e) The length b of the shorter side, in mm, as shown in Fig 1, d), is to be taken as: $b = A/a$

where:

A : Area of the plate, in mm²

a : Length, in mm, defined in item d).

- f) The stresses from the direct strength analysis are to be transformed into the local coordinate system of the equivalent rectangular panel. These stresses are to be used for the buckling assessment.

2.3.3 Modelling of an unstiffened panel with triangular geometry

Unstiffened panels with triangular geometry are to be idealised to equivalent rectangular panels for plate buckling assessment according to the following procedure:

- a) Medians are constructed as shown in Fig 2a).
- b) The longest median is identified as shown in Fig 2, b). This median, the length of which is ℓ_1 in mm, defines the longitudinal direction for the capacity model.
- c) The width ℓ_2 of the model, in mm, as shown in Fig 2, c), is to be taken as: $\ell_2 = A/\ell_1$

where:

A : Area of the plate, in mm².

- d) The lengths of the shorter side b and the longer side a , in mm, of the equivalent rectangular panel are to be taken as:

$$b = \frac{\ell_2}{C_{tri}}$$

$$a = \ell_1 C_{tri}$$

where:

$$C_{tri} = 0,4 \frac{\ell_2}{\ell_1} + 0,6$$

- e) The stresses from the direct strength analysis are to be transformed into the local coordinate system of the equivalent rectangular panel. These stresses are to be used for the buckling assessment.

Figure 1 : Irregular unstiffened panel modelling

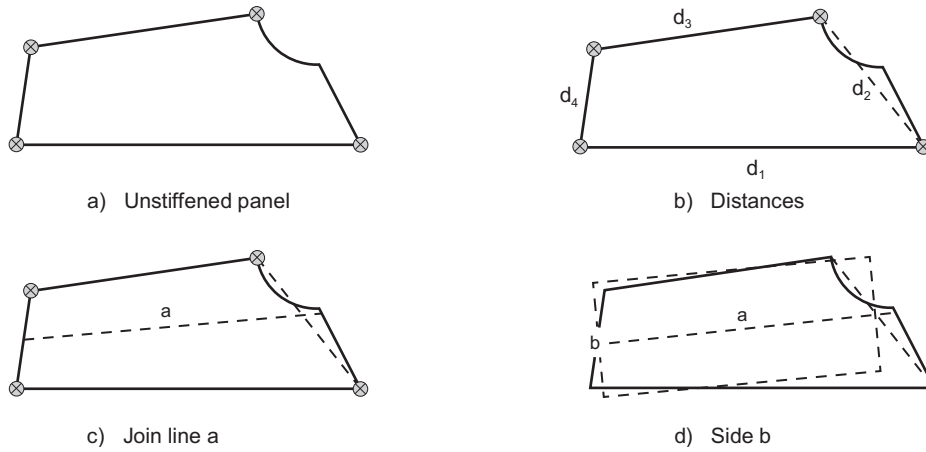
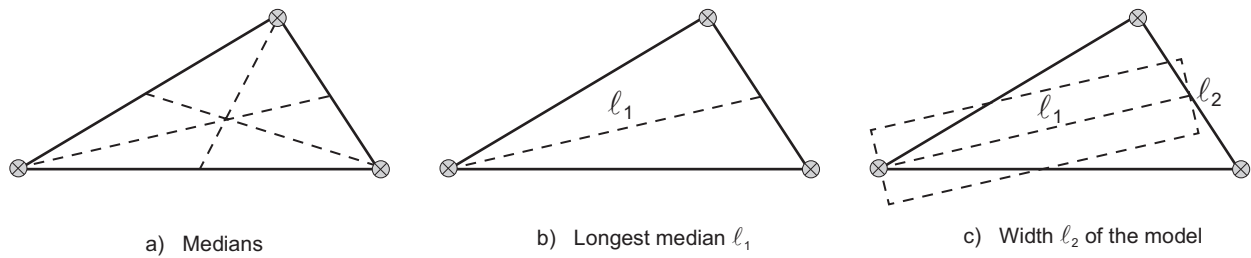

Figure 2 : Triangular unstiffened panel modelling



2.4 Reference stresses

2.4.1 The stress distribution is to be taken from the direct strength analysis and applied to the buckling model.

2.4.2 The reference stresses are to be calculated using the stress based reference stresses, as defined in App 1.

2.5 Lateral pressure

2.5.1 The lateral pressure applied to the direct strength analysis is also to be applied to the buckling assessment unless otherwise stated in the applicable Rules.

2.5.2 Where the lateral pressure is not constant over a buckling panel defined by a number of finite plate elements, an average lateral pressure P_{avr} , in N/mm^2 , is calculated using the following formula:

$$P_{avr} = \frac{\sum_{i=1}^n A_i P_i}{\sum_{i=1}^n A_i}$$

where:

- A_i : Area of the i-th plate element, in mm^2
- P_i : Lateral pressure of the i-th plate element, in N/mm^2
- n : Number of finite elements in the buckling panel.

2.6 Buckling criteria

2.6.1 UP-A

The compressive buckling strength of UP-A is to satisfy the following criterion:

$$\eta_{UP-A} \leq \eta_{all}$$

where:

- η_{UP-A} : Maximum plate panel utilisation factor calculated according to Method A, as defined in Sec 5, [2.2].

2.6.2 UP-B

The compressive buckling strength of UP-B is to satisfy the following criterion:

$$\eta_{UP-B} \leq \eta_{all}$$

where:

η_{UP-B} : Maximum plate panel utilisation factor calculated according to Method B, as defined in Sec 5, [2.2].

2.6.3 SP-A

The compressive buckling strength of SP-A is to satisfy the following criterion:

$$\eta_{SP-A} \leq \eta_{all}$$

where:

η_{SP-A} : Maximum stiffened panel utilisation factor taken as the maximum of:

- the overall stiffened panel capacity, as defined in Sec 5, [2.1]
- the plate capacity calculated according to Method A, as defined in Sec 5, [2.2]
- the stiffener buckling strength as defined in Sec 5, [2.3], considering separately the properties (thickness, dimensions), the pressures defined in [2.5.2] and the reference stresses of each EPP at both sides of the stiffener.

Note 1: The stiffener buckling capacity check can only be fulfilled when the overall stiffened panel capacity, as defined in Sec 5, [2.1], is satisfied.

2.6.4 SP-B

The compressive buckling strength of SP-B is to satisfy the following criterion:

$$\eta_{SP-B} \leq \eta_{all}$$

where:

η_{SP-B} : Maximum stiffened panel utilisation factor taken as the maximum of:

- the overall stiffened panel capacity, as defined in Sec 5, [2.1]
- the plate capacity calculated according to Method B, as defined in Sec 5, [2.2]
- the stiffener buckling strength as defined in Sec 5, [2.3], considering separately the properties (thickness, dimensions), the pressures defined in [2.5.2] and the reference stresses of each EPP at both sides of the stiffener.

Note 1: The stiffener buckling capacity check can only be fulfilled when the overall stiffened panel capacity, as defined in Sec 5, [2.1], is satisfied.

2.6.5 Web plate in way of openings

The web plate of primary supporting members in way of openings is to satisfy the following criterion:

$$\eta_{opening} \leq \eta_{all}$$

where:

$\eta_{opening}$: Maximum web plate utilisation factor in way of openings, as defined in Sec 5, [2.4].

3 Corrugated bulkheads**3.1 General**

3.1.1 Three buckling failure modes are to be assessed on corrugated bulkheads:

- corrugation overall column buckling
- corrugation flange panel buckling
- corrugation web panel buckling.

3.2 Reference stresses

3.2.1 Each corrugation flange and web panel is to be assessed.

3.2.2 The membrane stresses at element centroid are to be used.

3.2.3 For the application of this requirement:

b : Width of the considered member (flange or web) of the corrugation.

The maximum normal stress σ_x parallel to the corrugation is the maximum of the two following stresses:

- the normal stress parallel to the corrugation taken at $b/2$ from the corrugation ends
- the normal stress parallel to the corrugation within the mid-span of the corrugation.

When a corrugation end is fitted with a shedder plate, the normal stress parallel to the corrugation at this end is to be taken at $b/2$ from the intersection of the shedder plate with the point at mid-breadth of the flange or of the web, as the case may be.

The maximum shear stress is the shear stress which is maximum at the corrugation flange or web at the point $b/2$ from ends as defined above for the normal stress parallel to the corrugation.

The in-plane stresses σ_x and σ_y and the shear stress τ are to be taken as the element stresses averaged over the width of the considered member (flange or web) at the considered location.

When the stress value at $b/2$ from ends cannot be obtained directly from FEA element, the stress at this location is to be obtained by interpolation. This interpolation is to be made on elements extending over a distance equal to $3b$ at a point located at $b/2$ from the end of the corrugation or from the intersection of the shedder plate if fitted, measured at mid-breadth of the flange or of the web. The interpolation of the in-plane stresses σ_x and σ_y is to be made in accordance with App 1, [2.1].

The shear stress at $b/2$ is obtained by linear interpolation between the elements the closest to $b/2$ location.

3.2.4 Where more than one plate thickness is used for a flange or web panel, the maximum stress is to be obtained for each thickness range and is to be checked with the buckling criteria for each thickness.

3.3 Overall column buckling

3.3.1 The overall buckling failure mode of corrugated bulkheads subjected to axial compression is to be checked for column buckling (e.g. horizontally corrugated bulkheads and vertically corrugated bulkheads subjected to local vertical forces), see Tab 1.

Table 1 : Application of overall column buckling for corrugated bulkheads

Bulkhead orientation	Corrugation orientation	
	Horizontal	Vertical
Longitudinal or Transverse	Required	Required, when subjected to local vertical forces (e.g. crane loads)

3.3.2 Each corrugation unit, i.e. each single corrugation made up of half flange/web/half flange, as shown in grey in Fig 3, is to satisfy the following criterion:

$$\eta_{Overall} \leq \eta_{all}$$

where:

$\eta_{Overall}$: Maximum overall column utilisation factor, as defined in Sec 5, [3.1] and Sec 5, [3.1.3], considering the corrugation unit as a pillar with an unsupported length equal to the length of the corrugation.

Figure 3 : Single corrugation

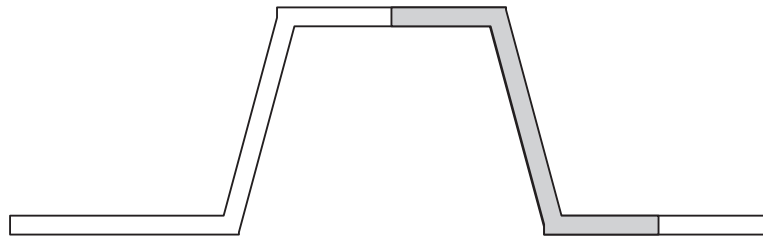

3.3.3 End constraint factor f_{end} to be applied corresponds to:

- pinned ends, in general
- fixed end support, in case of stool having a width exceeding 2 times the depth of the corrugation.

3.4 Local buckling

3.4.1 The compressive buckling strength of a unit flange and a unit web of corrugated bulkheads is to satisfy the following criterion:

$$\eta_{Corr} \leq \eta_{all}$$

where:

η_{Corr} : Maximum unit flange or unit web utilisation factor, as defined in Sec 5, [3.2.1].

Two stress combinations are to be considered for the application of this criterion:

- the maximum normal stress σ_x parallel to the corrugation, combined with the stress σ_y perpendicular to the corrugation and with the shear stress τ , at the location where the maximum normal stress parallel to the corrugation occurs.
- the maximum shear stress τ , combined with the normal stress σ_x parallel to the corrugation and with the stress σ_y perpendicular to the corrugation, at the location where the maximum shear stress occurs.

The buckling assessment is to be performed with an aspect ratio α equal to 2, and for the member thicknesses where the maximum compressive/shear stress occurs (see [3.2.4]).

4 Vertically stiffened side shell of single-side skin ships

4.1 Buckling criteria

4.1.1 Side shell plating

The compressive buckling strength of the vertically stiffened side shell plating of single-side skin ships, between hopper and topside tanks, is to satisfy the following criterion:

$$\eta_{VSS} \leq \eta_{all}$$

where:

η_{VSS} : Maximum vertically stiffened side shell plating utilisation factor calculated according to Method A as defined in Sec 5, [2.2.1] and considering the boundary conditions and stress combinations detailed in a) and b) hereafter:

a) 4 edges simply supported (cases 1, 2 and 15 of Sec 5, Tab 4):

- Pure vertical stress:

The maximum vertical stress of stress elements is used with $\alpha = 1$ and $\psi_x = 1$.

- Maximum vertical stress combined with longitudinal and shear stress:

The maximum vertical stress in the buckling panel plus the shear and longitudinal stresses at the location where the maximum vertical stress occurs is used with $\alpha = 2$ and $\psi_x = \psi_y = 1$

The plate thickness to be considered in the buckling strength check is the one where the maximum vertical stress occurs.

- Maximum shear stress combined with longitudinal and vertical stress:

The maximum shear stress in the buckling panel plus the longitudinal and vertical stresses at the location where maximum shear stress occurs is used with $\alpha = 2$ and $\psi_x = \psi_y = 1$

The plate thickness to be considered in the buckling strength check is the one where the maximum shear stress occurs.

b) The 2 shorter edges of the plate panel clamped (cases 11, 12 and 16 of Sec 5, Tab 4):

- Distributed longitudinal stress associated with vertical and shear stress:

The actual size of the buckling panel is used to define α

The average values for longitudinal, vertical and shear stresses are to be used $\psi_x = \psi_y = 1$

The plate thickness to be considered in the buckling strength check is the minimum thickness of the buckling panel.

4.1.2 Side frames

The buckling strength of side frames of single-side skin ships, between hopper and topside tanks, is to satisfy the following criterion:

$$\eta_{Stiffener} \leq \eta_{all}$$

where:

$\eta_{Stiffener}$: Maximum stiffener utilisation factor, as defined in Sec 5, [2.3].

5 Struts, pillars and cross ties

5.1 Buckling criteria

5.1.1 The compressive buckling strength of struts, pillars and cross ties is to satisfy the following criterion:

$$\eta_{Pillar} \leq \eta_{all}$$

The buckling strength of elementary plate panels of cross ties is to satisfy the following criterion:

$$\eta_{Plate} \leq \eta_{all}$$

where:

η_{Pillar} : Maximum utilisation factor of struts, pillars or cross ties, as defined in Sec 5, [3.1].

η_{Plate} : Maximum plate utilisation factor calculated according to UP-B, as defined in Sec 5, [2.2].

5.1.2 The buckling strength of pillars subject to axial force and bending moments may be required to be checked based on direct calculations. The buckling criterion is to be especially considered by the Society.

Section 5 Buckling Capacity

Symbols

- A_p : Net sectional area of the stiffener attached plating, in mm², taken as $A_p = s t_p$
 A_s : Net sectional area of the stiffener without attached plating, in mm²
 A_{s_eff} : Net sectional area of the stiffener, in mm², without attached plating and considering a reduced web thickness t_{w_red} in case of flat bars
 a : Length of the longer side of the plate panel, in mm
 b : Length of the shorter side of the plate panel, in mm
 b_{eff} : Effective width of the attached plating of a stiffener, in mm, as defined in [2.3.4]
 b_{eff1} : Effective width of the attached plating of a stiffener, in mm, without the shear lag effect, taken as:
 - when $\sigma_x > 0$
 - for prescriptive assessment:
$$b_{eff1} = \frac{C_{x1}b_1 + C_{x2}b_2}{2}$$
 - for FE analysis:
$$b_{eff1} = C_x b$$
 - when $\sigma_x \leq 0$:
$$b_{eff1} = b$$
- b_f : Breadth of the stiffener flange, in mm
 b_1, b_2 : Width of the plate panel on each side of the considered stiffener, in mm
 C_{x1}, C_{x2} : Reduction factor define in Tab 4, calculated for the EPP1 and EPP2 on each side of the considered stiffener according to case 1
 C_x : Reduction factor as defined in [2.2.3]
 d : Length, in mm, of the side parallel to the axis of the cylinder corresponding to the curved plate panel, as shown in Tab 5
 d_f : Distance in mm, for the extension of flange for L2 profiles, as shown in Fig 1
 E : Young's modulus of the material, in N/mm²
 e_f : Distance, in mm, from the attached plating to the flange centre, as shown in Fig 1, depending on the profile type:
 - $e_f = h_w$ for flat bars
 - $e_f = h_w - 0,5 t_f$ for bulb bars
 - $e_f = h_w + 0,5 t_f$ for angle bars, T-bars and L2 bars
- F_{long} : Correction factor defined in [2.2.4]
 F_{tran} : Correction factor defined in [2.2.5]
 h_w : Depth of the stiffener web, in mm, as shown in Fig 1 and Fig 2
 I_{eff} : Moment of inertia of the stiffener, in cm⁴, including effective width of the attached plating according to [2.3.4] and considering a reduced web thickness t_{w_red} in case of flat bars, without being taken less than:
$$\frac{s t_p^3}{12 \cdot 10^4}$$
- ℓ : Span of the stiffener, in mm, equal to the spacing between the primary supporting members
 R : Radius of the curved plate panel, in mm
 R_{eH_P} : Specified minimum yield stress of the plate, in N/mm²
 R_{eH_S} : Specified minimum yield stress of the stiffener, in N/mm²
 S : Partial safety factor, to be taken as:
 - for structures exposed to local concentrated loads:
$$S = 1,1$$
 - for stiffeners located on the hatchway coamings, the sloping plate of the topside and hopper tanks, the inner bottom, the inner side if any, the side shell of single-side skin construction between hopper and topside tanks and the transverse bulkheads top and bottom stools of ships carrying dry cargo in bulk and having a length greater than 150 m:
$$S = 1,15$$

- for all the other cases:

$$S = 1,0$$

- s : Stiffener spacing, in mm
 t_p : Net thickness of the plate panel, in mm
 t_w : Net thickness of the stiffener web, in mm
 t_{w_red} : Reduced web thickness, in mm, to account for the decrease of stiffness due to local lateral deformation in the case of flat bars, to be taken equal to:

$$t_{w_red} = t_w \left[1 - \frac{2\pi^2}{3} \left(\frac{h_w}{s} \right)^2 \left(1 - \frac{b_{eff1}}{s} \right) \right]$$

without being taken less than 0,05 t_w

- t_f : Net thickness of the stiffener flange, in mm
 x axis : For a rectangular buckling panel, local axis parallel to its long edge
 y axis : For a rectangular buckling panel, local axis perpendicular to its long edge
 α : Aspect ratio of the plate panel, to be taken as:

$$\alpha = \frac{a}{b}$$

- β : Coefficient taken as:

$$\beta = \frac{1 - \Psi}{\alpha}$$

- ω : Coefficient taken as: ω = Min (3 ; α)
 σ_x : Stress applied on the edge along x axis of the buckling panel, in N/mm²
 σ_y : Stress applied on the edge along y axis of the buckling panel, in N/mm²
 σ₁ : Maximum stress, in N/mm²
 σ₂ : Minimum stress, in N/mm²
 σ_E : Elastic buckling reference stress, in N/mm², to be taken as:

- for the application of plate limit state according to [2.2.1]:

$$\sigma_E = \frac{\pi^2 E}{12(1 - \nu^2)} \left(\frac{t_p}{b} \right)^2$$

- for the application of curved plate panels according to [2.2.6]:

$$\sigma_E = \frac{\pi^2 E}{12(1 - \nu^2)} \left(\frac{t_p}{d} \right)^2$$

- τ : Applied shear stress, in N/mm²
 ν : Poisson's ratio of the material
 Ψ : Edge stress ratio, to be taken as:

$$\Psi = \frac{\sigma_2}{\sigma_1}$$

- γ : Stress multiplier factor acting on loads. When γ is such that the loads reach the interaction formulae, then: γ = γ_c
 γ_c : Stress multiplier factor at failure
 γ_{GEB} : Stress multiplier factor of global elastic buckling capacity.

1 General

1.1 Scope

1.1.1 This Section contains the methods for determination of the buckling capacity of plate panels, stiffeners, primary supporting members, struts, pillars, cross ties and corrugated bulkheads.

1.1.2 For the application of this Section, the stresses σ_x, σ_y and τ applied on the structural members are defined in:

- Sec 3 for the prescriptive requirements
- Sec 4 for the FE analysis requirements.

1.1.3 Ultimate buckling capacity

The ultimate buckling capacity is calculated by applying the actual stress combination and then increasing or decreasing the stresses proportionally until the interaction formulae defined in [2.1.1], [2.2.1], and [2.3.3] are equal to 1,0.

1.1.4 Buckling utilisation factor

The buckling utilisation factor η of the structural member is equal to the highest utilisation factor obtained for the different buckling modes.

1.1.5 Lateral pressure

The lateral pressure is to be considered as constant in the buckling strength assessment.

2 Buckling capacity of plates and stiffeners

2.1 Overall stiffened panel capacity

2.1.1 The elastic stiffened panel limit state is based on the following interaction formula, which sets a precondition for the buckling check of stiffeners in accordance with [2.3.4]:

$$\frac{\gamma}{\gamma_{GEB}} = 1$$

where the stress multiplier factor corresponding to global elastic buckling capacity, γ_{GEB} , is to be calculated based on the following formulae:

- for $\tau \neq 0$ and ($\sigma_x > 0$ or $\sigma_y > 0$): $\gamma_{GEB} = \gamma_{GEB,bi+\tau}$
- for $\tau = 0$ and ($\sigma_x > 0$ or $\sigma_y > 0$): $\gamma_{GEB} = \gamma_{GEB,bi}$
- for $\tau \neq 0$ and ($\sigma_x \leq 0$ and $\sigma_y \leq 0$): $\gamma_{GEB} = \gamma_{GEB,\tau}$

where:

$\gamma_{GEB,bi+\tau}$, $\gamma_{GEB,bi}$, $\gamma_{GEB,\tau}$: stress multiplier factors for different load combinations as defined in [2.1.2], [2.1.3] and [2.1.4], respectively

For the calculation of $\gamma_{GEB,bi+\tau}$, $\gamma_{GEB,bi}$ and $\gamma_{GEB,\tau}$, neither σ_x nor σ_y shall be taken less than 0

σ_x , σ_y : Applied normal stresses to the plate panel, in N/mm², to be taken as defined in [2.2.7]

τ : Applied shear stress, in N/mm², to be taken as defined in [2.2.7].

2.1.2 The stress multiplier factor $\gamma_{GEB,bi}$ for the stiffened panel subjected to biaxial loads is taken as:

$$\gamma_{GEB,bi} = \frac{\pi^2 [D_{11}L_{B2}^4 + 2(D_{12} + D_{33})n^2L_{B1}^2L_{B2}^2 + n^4D_{22}L_{B1}^4]}{L_{B1}^2L_{B2}^2 [L_{B2}^2N_x + n^2L_{B1}^2N_y]}$$

where:

N_x : Load per unit length applied on the edge along x axis of the stiffened panel, in N/mm, taken as:

$$N_x = \sigma_{x,av} (A_p + A_{s,eff}) / s$$

For stiffened panels fitted with U-type stiffeners, stiffener spacing s is taken as:

$$s = b_1 + b_2$$

b_1 and b_2 are defined at the head of the Section and Fig 2 is specific to U-Types

N_y : Load per unit length applied on the edge along y axis of the stiffened panel, in N/mm, taken as:

$$N_y = c \sigma_y t_p$$

L_{B1} : Stiffener span, in mm, equal to spacing between primary supporting members, i.e. $L_{B1} = \ell$

For vertically stiffened side shell of single side skin bulk carriers, $L_{B1} = 0.8\ell$

L_{B2} : Width of the stiffened panel, in mm, taken as 6 times the stiffener spacing, i.e. $6s$

n : Number of half waves along the direction perpendicular to the stiffener axis. The factor $\gamma_{GEB,bi}$ is to be minimized with respect to the wave parameter n , i.e. to be taken as the smallest value larger than zero

c : Factor taking into account the stresses in the attached plating acting perpendicular to the stiffener axis:

- for $0 \leq \psi \leq 1$:

$$c = 0,5(1 + \psi)$$

- for $\psi < 0$:

$$c = \frac{1}{2(1 - \psi)}$$

ψ : Edge stress ratio for case 2 according to Tab 4

$\sigma_{x,av}$: Average stress for both plate and stiffener with Poisson correction, taken as:

- for $\sigma_x > 0$ and $\sigma_y > 0$:

$$\sigma_{x,av} = \sigma_x - v c \sigma_y A_{s,eff} / (A_p + A_{s,eff}) \geq 0$$

- for $\sigma_x < 0$ or $\sigma_y < 0$:

$$\sigma_{x,av} = \sigma_x$$

D_{11} , D_{12} , D_{22} , D_{33} : Bending stiffness coefficients, in N.mm, of the stiffened panel, defined in general as:

$$D_{11} = \frac{E I_{eff} 10^4}{s}$$

$$D_{12} = \frac{Et_p^3 \nu}{12(1-\nu^2)}$$

$$D_{22} = \frac{Et_p^3}{12(1-\nu^2)}$$

$$D_{33} = \frac{Et_p^3}{12(1+\nu)}$$

For stiffened panels fitted with U-type stiffeners, D_{12} and D_{22} are defined as:

$$D_{12} = \nu D_{22}$$

$$D_{22} = \frac{Et_p^3}{12(1-\nu^2)} \left[1,2 + 4,8 \times \text{Min} \left(1, 0 \frac{b_1^2}{h_w(b_1 + b_2)} \right) \times \text{Min} \left(1, 0 \left(\frac{t_w}{t_p} \right)^3 \right) \right]$$

h_w : Breadth of U-type stiffener web a defined in Fig 2

2.1.3 The stress multiplier factor $\gamma_{GEB,\tau}$ for the stiffened panel subjected to pure shear load is taken as:

- for $D_{11}D_{22} \geq (D_{12} + D_{33})^2$:

$$\gamma_{GEB,\tau} = \frac{\sqrt[4]{D_{11}^3 D_{22}}}{(L_{B1}/2)^2 N_{xy}} \left[8,125 + 5,64 \sqrt{\frac{(D_{12} + D_{33})^2}{D_{11} D_{22}}} - 0,6 \frac{(D_{12} + D_{33})^2}{D_{11} D_{22}} \right]$$

- for $D_{11}D_{22} < (D_{12} + D_{33})^2$:

$$\gamma_{GEB,\tau} = \frac{\sqrt{2D_{11}(D_{12} + D_{33})}}{(L_{B1}/2)^2 N_{xy}} \left[8,3 + 1,525 \frac{D_{11} D_{22}}{(D_{12} + D_{33})^2} - 0,493 \frac{D_{11}^2 D_{22}^2}{(D_{12} + D_{33})^4} \right]$$

where:

N_{xy} : τt_p

2.1.4 The stress multiplier factor $\gamma_{GEB,bi+\tau}$ for the stiffened panel subjected to combined loads is taken as:

$$\gamma_{GEB,bi+\tau} = \frac{1}{2} \gamma_{GEB,\tau} \left[-\frac{1}{\gamma_{GEB,bi}} + \sqrt{\frac{1}{\gamma_{GEB,bi}^2} + 4 \frac{1}{\gamma_{GEB,\tau}^2}} \right]$$

where $\gamma_{GEB,bi}$ and $\gamma_{GEB,\tau}$ are as defined in [2.1.2] and [2.1.3], respectively.

2.2 Plate capacity

2.2.1 Plate limit state

a) The plate limit state is based on the following interaction formulae:

$$\bullet \left(\frac{\gamma_{c1} \sigma_x S}{\sigma_{cx}'} \right)^{e_0} + \left(\frac{\gamma_{c1} \sigma_y S}{\sigma_{cy}'} \right)^{e_0} + \left(\frac{\gamma_{c1} |\tau| S}{\tau_c} \right)^{e_0} - \Omega = 1$$

with:

$$\Omega = B \left(\frac{\gamma_{c1} \sigma_x S}{\sigma_{cx}'} \right)^{e_0/2} \left(\frac{\gamma_{c1} \sigma_y S}{\sigma_{cy}'} \right)^{e_0/2}$$

• when $\sigma_x \geq 0$:

$$\left(\frac{\gamma_{c2} \sigma_x S}{\sigma_{cx}'} \right)^{2/\beta_p^{0,25}} + \left(\frac{\gamma_{c2} |\tau| S}{\tau_c} \right)^{2/\beta_p^{0,25}} = 1$$

• when $\sigma_y \geq 0$:

$$\left(\frac{\gamma_{c3} \sigma_y S}{\sigma_{cy}'} \right)^{2/\beta_p^{0,25}} + \left(\frac{\gamma_{c3} |\tau| S}{\tau_c} \right)^{2/\beta_p^{0,25}} = 1$$

$$\bullet \frac{\gamma_{c4} |\tau| S}{\tau_c} = 1$$

where:

σ_x, σ_y : Normal stresses applied on the plate panel, in N/mm², to be taken as defined in [2.2.7]

τ : Shear stress applied on the plate panel, in N/mm², to be taken as defined in [2.2.7]

σ_{cx}' : Ultimate buckling stress, in N/mm², in the direction parallel to the longer edge of the buckling panel, as defined in [2.2.3]

- σ_{cy}' : Ultimate buckling stress, in N/mm², in the direction parallel to the shorter edge of the buckling panel, as defined in [2.2.3]
- τ_c' : Ultimate buckling shear stresses, in N/mm², as defined in [2.2.3]
- $\gamma_{c1}, \gamma_{c2}, \gamma_{c3}, \gamma_{c4}$: Stress multiplier factors at failure for each of the above different limit states.
 γ_{c2} and γ_{c3} are to be considered only when $\sigma_x \geq 0$ and $\sigma_y \geq 0$, respectively
- B, e_0 : Coefficients given in Tab 1.

b) The stress multiplier factor at failure, γ_c , is taken as: $\gamma_c = \text{Min} (\gamma_{c1} ; \gamma_{c2} ; \gamma_{c3} ; \gamma_{c4})$.

Figure 1 : Stiffener cross-sections

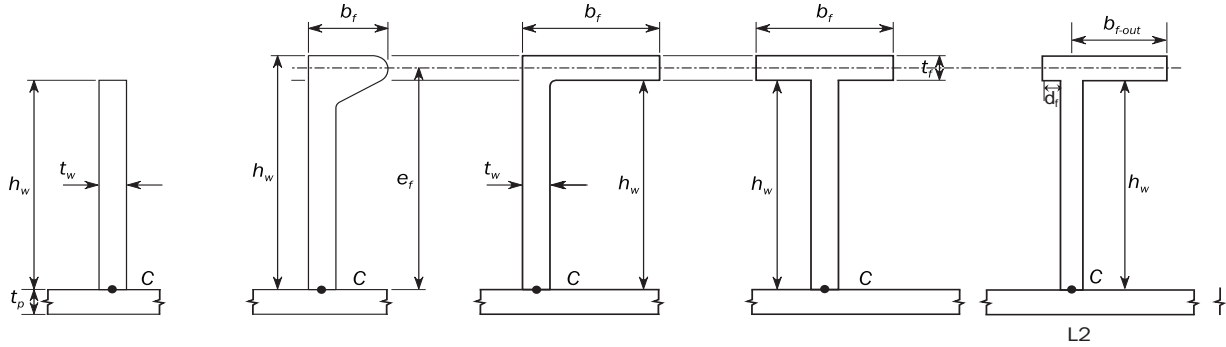

Figure 2 : U-type stiffener cross-section

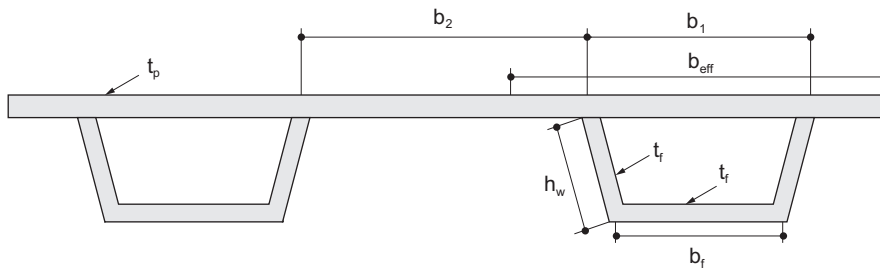

Table 1 : Coefficients B and e₀

Applied stresses	B	e ₀
$\sigma_x \geq 0$ and $\sigma_y \geq 0$	$0,7 - 0,3 \beta_p / \alpha^2$	$2 / \beta_p^{0,25}$
$\sigma_x < 0$ or $\sigma_y < 0$	1,0	2,0

Note 1:
 β_p : Plate slenderness parameter taken as:

$$\beta_p = \frac{b}{t_p} \sqrt{\frac{R_{eH-P}}{E}}$$

Table 2 : Coefficient c₁

Plate panels	c ₁
SP-A	$c_1 = \left(1 - \frac{1}{\alpha}\right) \geq 0$
UP-A	
Vertically stiffened single-side skin between hopper and topside tanks	
Corrugations of corrugated bulkhead	
SP-B	$c_1 = 1$
UP-B	

2.2.2 Reference degree of slenderness

The reference degree of slenderness is to be taken as:

$$\lambda = \sqrt{\frac{R_{eH,P}}{K\sigma_E}}$$

where:

K : Buckling factor, as defined in Tab 4 for plane plate panels and Tab 5 for curved plate panels.

2.2.3 Ultimate buckling stresses

The ultimate buckling stresses of plate panels, in N/mm², are to be taken as:

$$\sigma_{cx}' = C_x R_{eH,P}$$

$$\sigma_{cy}' = C_y R_{eH,P}$$

The ultimate buckling stress of plate panels subject to shear, in N/mm², is to be taken as:

$$\tau_c' = C_\tau \frac{R_{eH,P}}{\sqrt{3}}$$

where:

C_x, C_y, C_τ : Reduction factors, as defined in Tab 4.

- for the first equation of [2.2.1]:
when $\sigma_x < 0$ or $\sigma_y < 0$, the reduction factors are to be taken as follows:

$$C_x = C_y = C_\tau = 1$$

- in the other cases:
C_y is calculated according to Tab 4, using the values of c₁ given in Tab 2.

The boundary conditions for the plates are to be considered as simply supported: see case 1, case 2 and case 15 of Tab 4.

If the boundary conditions differ significantly from the condition ‘simple support’, a more appropriate boundary condition can be applied, chosen from the different cases of Tab 4, subject to the agreement of the Society.

2.2.4 Correction factor F_{long}

The correction factor F_{long} depending on the edge stiffener types on the longer side of the buckling panel is defined in Tab 3. An average value of F_{long} is to be used for the plate panels having different edge stiffeners. For stiffener types other than those mentioned in Tab 3, the value of c is to be agreed by the Society. In such a case, a value of c higher than those mentioned in Tab 3 can be used, provided it is verified by buckling strength check of panel using non-linear FEA and deemed appropriate by the Society.

2.2.5 Correction factor F_{tran}

The correction factor F_{tran} is to be taken as:

- For transversely framed EPP of single-side skin ships, between the hopper and top wing tank:
 - when the two adjacent frames are supported by one tripping bracket fitted in way of the adjacent plate panels:
F_{tran} = 1,25
 - when the two adjacent frames are supported by two tripping brackets each fitted in way of the adjacent plate panels:
F_{tran} = 1,33
 - elsewhere:
F_{tran} = 1,15

- For the attached plate of a U-type stiffener fitted on a hatch cover:

$$F_{tran} = \text{Max} (3 - 0,08 (F_{tran0} - 6)^2, 1,0) \leq 2,25$$

where:

$$F_{tran0} = \text{Min} \left(\frac{b_2}{b_1} + \frac{6b_2^2}{\pi^2 h_w (b_1 + b_2)} \left(\frac{t_w}{t_p} \right)^3 ; 6 \right) \quad \text{for EPP } b_2$$

$$F_{tran0} = \text{Min} \left(\frac{b_1}{b_2} + \frac{6b_1^2}{\pi^2 h_w (b_2 + b_1)} \left(\frac{t_w}{t_p} \right)^3 ; 6 \right) \quad \text{for EPP } b_1$$

with b₁, b₂ and h_w as defined in Fig 2

Coefficient F defined in Case 2 of Tab 4 is to be replaced by the following formula:

$$F = \left[1 - \left(\frac{K_y}{0,91 F_{tran}} - 1 \right) / \lambda_p^2 \right] c_1 \geq 0$$

- For other cases:

$$F_{tran} = 1$$

Table 3 : Correction factor F_{long}

Structural element types		F_{long}	
Unstiffened panel		1,0	
Stiffened panel	Stiffener not fixed at both ends	1,0	
	Stiffener fixed at both ends	Flat bar (c = 0,10)	$F_{long} = c + 1$ for $\frac{t_w}{t_p} > 1$ $F_{long} = c \left(\frac{t_w}{t_p}\right)^3 + 1$ for $\frac{t_w}{t_p} \leq 1$
		Bulb bar (c = 0,30)	
		Angle and L2 bars (c = 0,40)	
		T-bar (c = 0,30)	
		Girder of high rigidity (e.g. bottom transverse)	1,4
U-type profile fitted on hatch cover (1)	<ul style="list-style-type: none"> Plate on which the U-type profile is fitted including EPP b_1 and EPP b_2: <ul style="list-style-type: none"> for $b_2 < b_1$: $F_{long} = 1$ for $b_2 \geq b_1$: $F_{long} = \left(1,55 - 0,55 \frac{b_1}{b_2}\right) \left[1 + c \left(\frac{t_w}{t_p}\right)^3\right]$ Other plate of the U-type profile: $F_{long} = 1$ 		

(1) b_1 , b_2 and t_w are defined in Fig 2.

Table 4 : Buckling factor K and reduction factor C for plane plate panels

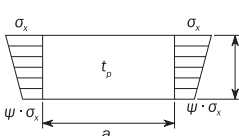
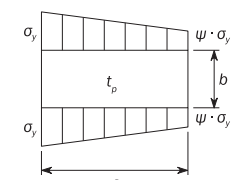
Case	Stress ratio ψ	Buckling factor K	Reduction factor C
Case 1 	$1 \geq \psi \geq 0$	$K_x = F_{long} \frac{8,4}{\psi + 1,1}$	<ul style="list-style-type: none"> when $\sigma_x \leq 0$: $C_x = 1,00$ when $\sigma_x > 0$: $C_x = 1,00$ for $\lambda \leq \lambda_c$ $C_x = c \left(\frac{1}{\lambda} - \frac{0,22}{\lambda^2}\right)$ for $\lambda > \lambda_c$ where: $c = (1,25 - 0,12\psi) \leq 1,25$ $\lambda_c = \frac{c}{2} \left(1 + \sqrt{1 - \frac{0,88}{c}}\right)$
	$0 > \psi > -1$	$K_x = F_{long} [7,63 - \psi (6,26 - 10 \psi)]$	
	$\psi \leq -1$	$K_x = F_{long} [5,975 (1 - \psi)^2]$	
Case 2 	$1 \geq \psi \geq 0$	$K_y = F_{tran} \frac{2 \left(1 + \frac{1}{\alpha^2}\right)^2}{1 + \psi + \frac{(1-\psi)(2,4 + 6,9f_1)}{100 \alpha^2}}$ <ul style="list-style-type: none"> when $\alpha \leq 6$: $f_1 = (1 - \psi)(\alpha - 1)$ when $\alpha > 6$: $f_1 = 0,6 \left(1 - \frac{6\psi}{\alpha}\right) \left(\alpha + \frac{14}{\alpha}\right)$ with $f_1 \leq 14,5 - \frac{0,35}{\alpha^2}$ 	

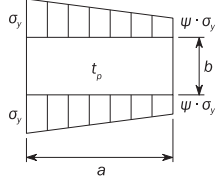
Case	Stress ratio ψ	Buckling factor K	Reduction factor C
<p>Case 2 (continued)</p> 	$0 > \psi \geq 1 - \frac{4\alpha}{3}$	$K_y = \frac{200F_{tran}(1 + \beta^2)^2}{(1 - f_3)(100 + 2,4\beta^2 + 6,9f_1 + 23f_2)}$ <ul style="list-style-type: none"> when $\alpha > 6 (1 - \psi)$: $f_1 = 0,6 \left(\frac{1}{\beta} + 14\beta \right)$ <p>with $f_1 \leq 14,5 - 0,35 \beta^2$ $f_2 = f_3 = 0$</p> when $3 (1 - \psi) \leq \alpha \leq 6 (1 - \psi)$: $f_1 = \frac{1}{\beta} - 1$ <p>$f_2 = f_3 = 0$</p> when $1,5 (1 - \psi) \leq \alpha < 3 (1 - \psi)$: $f_1 = \frac{1}{\beta} - (2 - \omega\beta)^4 - 9(\omega\beta - 1) \left(\frac{2}{3} - \beta \right)$ <p>$f_2 = f_3 = 0$</p> when $1 - \psi \leq \alpha < 1,5 (1 - \psi)$: <ul style="list-style-type: none"> for $\alpha > 1,5$: $f_1 = 2 \left[\frac{1}{\beta} - 16 \left(1 - \frac{\omega}{3} \right)^4 \right] \left(\frac{1}{\beta} - 1 \right)$ <p>$f_2 = 3\beta - 2$ $f_3 = 0$</p> for $\alpha \leq 1,5$: $f_1 = 2 \left(\frac{1,5}{1 - \psi} - 1 \right) \left(\frac{1}{\beta} - 1 \right)$ $f_2 = \frac{\psi(1 - 16f_4^2)}{1 - \alpha}$ <p>$f_3 = 0$ $f_4 = [1,5 - \text{Min}(1,5; \alpha)]^2$</p> when $0,75 (1 - \psi) \leq \alpha < 1 - \psi$: $f_1 = 0$ $f_2 = 1 + 2,31(\beta - 1) - 48 \left(\frac{4}{3} - \beta \right) f_4^2$ $f_3 = 3f_4(\beta - 1) \left(\frac{f_4}{1,81} - \frac{\alpha - 1}{1,31} \right)$ <p>$f_4 = [1,5 - \text{Min}(1,5; \alpha)]^2$</p> 	<ul style="list-style-type: none"> when $\sigma_y \leq 0$: $C_y = 1,00$ when $\sigma_y > 0$: $C_y = c \left[\frac{1}{\lambda} - \frac{R + F^2 (H - R)}{\lambda^2} \right]$ <p>where: $c = (1,25 - 0,12 \Psi) \leq 1,25$ $R = \lambda \left(1 - \frac{\lambda}{c} \right)$ for $\lambda < \lambda_c$ $R = 0,22$ for $\lambda \geq \lambda_c$ $\lambda_c = \frac{c}{2} \left(1 + \sqrt{1 - \frac{0,88}{c}} \right)$</p> $F = \left[1 - \frac{\left(\frac{K}{0,91} - 1 \right)}{\lambda_p^2} \right] c_1 \geq 0$ <p>$\lambda_p^2 = \lambda^2 - 0,5$ with $1 \leq \lambda_p^2 \leq 3$ c_1 as defined in Tab 2 $H = \lambda - \frac{2\lambda}{c(T + \sqrt{T^2 - 4})} \geq R$ $T = \lambda + \frac{14}{15\lambda} + \frac{1}{3}$</p>
	$\psi < 1 - \frac{4\alpha}{3}$	$K_y = 5,972 F_{tran} \frac{\beta^2}{1 - f_3}$ <p>with:</p> $f_3 = f_5 \left(\frac{f_5}{1,81} + \frac{1 + 3\psi}{5,24} \right)$ $f_5 = \frac{9}{16} [1 + \text{Max}(-1; \psi)]^2$	

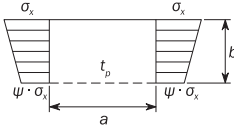
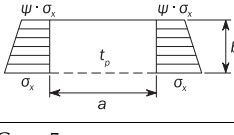
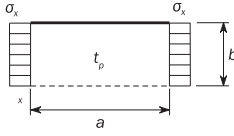
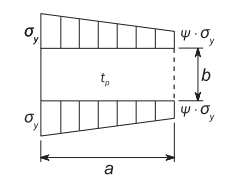
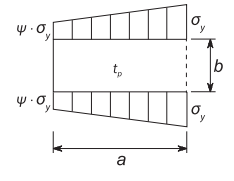
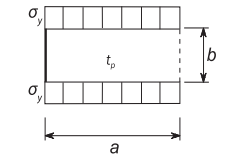
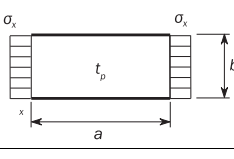
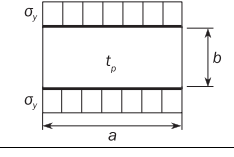
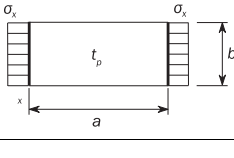
Case	Stress ratio ψ	Buckling factor K	Reduction factor C
<p>Case 3</p> 	$1 \geq \psi \geq 0$	$K_x = \frac{4 \left(0,425 + \frac{1}{\alpha^2} \right)}{3\psi + 1}$	<p>For UP-A:</p> $C_x = 1,00$ for $\lambda \leq 0,75$ $C_x = \frac{0,75}{\lambda}$ for $\lambda > 0,75$
	$0 > \psi \geq -1$	$K_x = 4 \left(0,425 + \frac{1}{\alpha^2} \right) (1 + \psi) - 5\psi (1 - 3,42\psi)$	
<p>Case 4</p> 	$1 \geq \psi \geq -1$	$K_x = \left(0,425 + \frac{1}{\alpha^2} \right) \frac{3 - \psi}{2}$	<p>For UP-B:</p> $C_x = 1,00$ for $\lambda \leq 0,7$
<p>Case 5</p> 	<p>–</p>	<ul style="list-style-type: none"> when $\alpha \geq 1,64$: $K_x = 1,28$ when $\alpha < 1,64$: $K_x = \frac{1}{\alpha^2} + 0,56 + 0,13\alpha^2$ 	$C_x = \frac{1}{\lambda^2 + 0,51}$ for $\lambda > 0,7$
<p>Case 6</p> 	$1 \geq \psi \geq 0$	$K_y = \frac{4(0,425 + \alpha^2)}{(3\psi + 1)\alpha^2}$	<p>For UP-A:</p> $C_y = 1,00$ for $\lambda \leq 0,75$ $C_y = \frac{0,75}{\lambda}$ for $\lambda > 0,75$
	$0 > \psi \geq -1$	$K_y = 4(0,425 + \alpha^2)(1 + \psi) \frac{1}{\alpha^2} - 5\psi [1 - (3,42\psi)] \frac{1}{\alpha^2}$	
<p>Case 7</p> 	$1 \geq \psi \geq -1$	$K_y = (0,425 + \alpha^2) \frac{(3 - \psi)}{2\alpha^2}$	<p>For UP-B:</p> $C_y = 1,00$ for $\lambda \leq 0,7$
<p>Case 8</p> 	<p>–</p>	$K_y = 1 + \frac{0,56}{\alpha^2} + \frac{0,13}{\alpha^4}$	$C_y = \frac{1}{\lambda^2 + 0,51}$ for $\lambda > 0,7$
<p>Case 9</p> 	<p>–</p>	$K_x = 6,97$	$C_x = 1,00$ for $\lambda \leq 0,83$ $C_x = 1,13 \left(\frac{1}{\lambda} - \frac{0,22}{\lambda^2} \right)$ for $\lambda > 0,83$
<p>Case 10</p> 	<p>–</p>	$K_y = 4 + \frac{2,07}{\alpha^2} + \frac{0,67}{\alpha^4}$	$C_y = 1,00$ for $\lambda \leq 0,83$ $C_y = 1,13 \left(\frac{1}{\lambda} - \frac{0,22}{\lambda^2} \right)$ for $\lambda > 0,83$
<p>Case 11</p> 	<p>–</p>	<ul style="list-style-type: none"> when $\alpha \geq 4$: $K_x = 4$ when $\alpha < 4$: $K_x = 4 + 2,74 \left(\frac{4 - \alpha}{3} \right)^4$ 	$C_x = 1,00$ for $\lambda \leq 0,83$ $C_x = 1,13 \left(\frac{1}{\lambda} - \frac{0,22}{\lambda^2} \right)$ for $\lambda > 0,83$

Case	Stress ratio ψ	Buckling factor K	Reduction factor C
<p>Case 12</p> 	—	$K_y = K_{y2}$ <p>with: $K_{y2} : K_y$ determined as per Case 2</p>	$C_y = C_{y2} \text{ for } \alpha < 2$ $C_y = \left(1,06 + \frac{1}{10\alpha}\right) C_{y2} \text{ for } \alpha \geq 2$ <p>where: $C_{y2} = C_y$ determined as per Case 2</p>
<p>Case 13</p> 	—	<ul style="list-style-type: none"> when $\alpha \geq 4$: $K_x = 6,97$ when $\alpha < 4$: $K_x = 6,97 + 3,1 \left(\frac{4-\alpha}{3}\right)^4$ 	$C_x = 1,00 \text{ for } \lambda \leq 0,83$ $C_x = 1,13 \left(\frac{1}{\lambda} - \frac{0,22}{\lambda^2}\right) \text{ for } \lambda > 0,83$
<p>Case 14</p> 	—	$K_y = \frac{6,97}{\alpha^2} + \frac{3,1}{\alpha^2} \left(\frac{4-\alpha}{3}\right)^4$	$C_y = 1,00 \text{ for } \lambda \leq 0,83$ $C_y = 1,13 \left(\frac{1}{\lambda} - \frac{0,22}{\lambda^2}\right) \text{ for } \lambda > 0,83$
<p>Case 15</p> 	—	$K_\tau = \sqrt{3} \left(5,34 + \frac{4}{\alpha^2}\right)$	
<p>Case 16</p> 	—	$K_\tau = \sqrt{3} \left[5,34 + \text{Max}\left(\frac{4}{\alpha^2}; \frac{7,15}{\alpha^{2,5}}\right)\right]$	
<p>Case 17</p> 	—	$K_\tau = \sqrt{3} \left(5,34 + \frac{4}{\alpha^2}\right) r$ <p>with r, the opening reduction factor taken as: $r = \left(1 - \frac{d_a}{a}\right) \left(1 - \frac{d_b}{b}\right)$ with $\frac{d_a}{a} \leq 0,7$ and $\frac{d_b}{b} \leq 0,7$</p>	$C_\tau = 1,00 \text{ for } \lambda \leq 0,84$ $C_\tau = \frac{0,84}{\lambda} \text{ for } \lambda > 0,84$
<p>Case 18</p> 	—	$K_\tau = \sqrt{3} \left(0,6 + \frac{4}{\alpha^2}\right)$	
<p>Case 19</p> 	—	$K_\tau = 8$	
<p>Edge boundary conditions:</p> <p>----- Plate edge free. ————— Plate edge simply supported. ————— Plate edge clamped.</p> <p>Note 1: The cases listed are general cases. Each stress component (σ_x, σ_y) is to be understood in local coordinates.</p>			

Table 5 : Buckling factor K and reduction factor C for curved plate panel with $R/t_p \leq 2500$

Case	Aspect ratio	Buckling factor K	Reduction factor C
Case 1 	$\frac{d}{R} \leq 0,5 \sqrt{\frac{R}{t_p}}$	$K = 1 + \frac{2}{3} \frac{d^2}{R t_p}$	<ul style="list-style-type: none"> for general application: $C_{ax} = 1,00$ for $\lambda \leq 0,25$ $C_{ax} = 1,233 - 0,933 \lambda$ for $0,25 < \lambda \leq 1,0$ $C_{ax} = \frac{0,30}{\lambda^3}$ for $1,0 < \lambda \leq 1,5$ $C_{ax} = \frac{0,20}{\lambda^2}$ for $\lambda > 1,5$ for curved single fields, e.g. bilge plating, which are bounded by plane panels: $C_{ax} = \frac{0,65}{\lambda^2} \leq 1,0$
	$\frac{d}{R} > 0,5 \sqrt{\frac{R}{t_p}}$	$K = 0,267 \frac{d^2}{R t_p} \left[3 - \frac{d}{R} \sqrt{\frac{t_p}{R}} \right] \geq 0,4 \frac{d^2}{R t_p}$	
Case 2 	$\frac{d}{R} \leq 1,63 \sqrt{\frac{R}{t_p}}$	$K = \frac{d}{\sqrt{R t_p}} + 3 \frac{(R t_p)^{0,175}}{d^{0,35}}$	<ul style="list-style-type: none"> for general application: $C_{tg} = 1,00$ for $\lambda \leq 0,4$ $C_{tg} = 1,274 - 0,686 \lambda$ for $0,4 < \lambda \leq 1,2$ $C_{tg} = \frac{0,65}{\lambda^2}$ for $\lambda > 1,2$ for curved single fields, e.g. bilge plating, which are bounded by plane panels: $C_{tg} = \frac{0,8}{\lambda^2} \leq 1,0$
	$\frac{d}{R} > 1,63 \sqrt{\frac{R}{t_p}}$	$K = 0,3 \frac{d^2}{R^2} + 2,25 \left(\frac{R^2}{d t_p} \right)^2$	
Case 3 	$\frac{d}{R} \leq \sqrt{\frac{R}{t_p}}$	$K = \frac{0,6d}{\sqrt{R t_p}} + \frac{\sqrt{R t_p}}{d} - 0,3 \frac{R t_p}{d^2}$	as in Case 2a
	$\frac{d}{R} > \sqrt{\frac{R}{t_p}}$	$K = 0,3 \frac{d^2}{R^2} + 0,291 \left(\frac{R^2}{d t_p} \right)^2$	
Case 4 	$\frac{d}{R} \leq 8,7 \sqrt{\frac{R}{t_p}}$	$K = \sqrt{3} \sqrt{28,3 + \frac{0,67 d^3}{R^{1,5} t_p^{1,5}}}$	$C_\tau = 1,00$ for $\lambda \leq 0,4$ $C_\tau = 1,274 - 0,686 \lambda$ for $0,4 < \lambda \leq 1,2$ $C_\tau = \frac{0,65}{\lambda^2}$ for $\lambda > 1,2$
	$\frac{d}{R} > 8,7 \sqrt{\frac{R}{t_p}}$	$K = \sqrt{3} \frac{0,28d^2}{R \sqrt{R t_p}}$	
Edge boundary conditions: - - - - - Plate edge free. ——— Plate edge simply supported. ——— Plate edge clamped.			

2.2.6 Curved plate panels

This requirement for curved plate limit state is applicable when $R/t_p \leq 2500$. Otherwise, the requirement for plate limit state given in [2.2.1] is applicable.

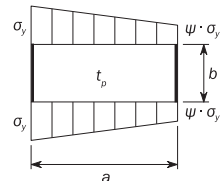
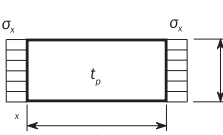
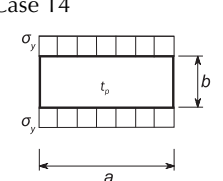
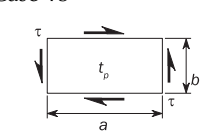
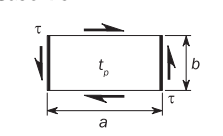
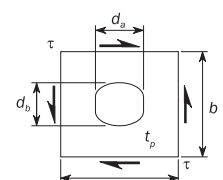
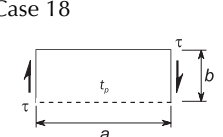
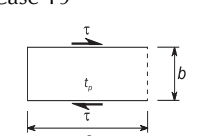
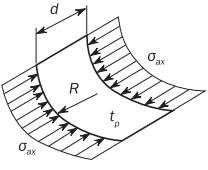
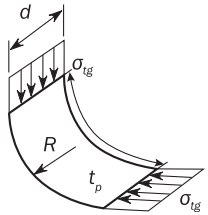
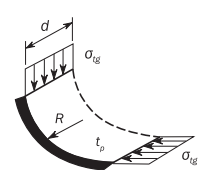
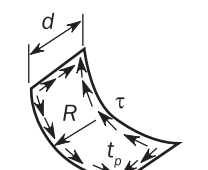
The curved plate limit state is based on the following interaction formula:

$$\left(\frac{\gamma_c \sigma_{ax} S}{C_{ax} R_{eH,p}} \right)^{1,25} + \left(\frac{\gamma_c \sigma_{tg} S}{C_{tg} R_{eH,p}} \right)^{1,25} + \left(\frac{\gamma_c \tau \sqrt{3} S}{C_\tau R_{eH,p}} \right)^2 - \gamma = 1$$

with:

$$\gamma = 0,5 \left(\frac{\gamma_c \sigma_{ax} S}{C_{ax} R_{eH_P}} \right) \left(\frac{\gamma_c \sigma_{tg} S}{C_{tg} R_{eH_P}} \right)$$

where:

- σ_{ax} : Axial stress applied to the cylinder corresponding to the curved plate panel, in N/mm².
In case of tensile axial stresses: $\sigma_{ax} = 0$
- σ_{tg} : Tangential stress applied to the cylinder corresponding to the curved plate panel, in N/mm².
In case of tensile tangential stresses: $\sigma_{tg} = 0$

C_{ax} , C_{tg} , C_{τ} : Buckling reduction factors of the curved plate panel, as defined in Tab 5.

The stress multiplier factor γ_c of the curved plate panel need not be taken less than the stress multiplier factor γ_c obtained from [2.2.1] for an expanded plane panel.

2.2.7 Normal and shear stresses applied to plate panels

The normal stresses σ_x and σ_y , in N/mm², to be applied for the overall stiffened panel capacity and the plate panel capacity calculations, as given in [2.1.1] and [2.2.1] respectively, are to be taken as follows:

- For FE analysis, the reference stresses as defined in Sec 4, [2.4].
- For prescriptive assessment of the overall stiffened panel capacity and the plate panel capacity, the axial or transverse compressive stresses at load calculation points of the considered stiffener or the considered elementary plate panel, as defined in the applicable Rules, respectively. However, in case of transverse stiffening arrangement, the transverse compressive stress used for the assessment of the overall stiffened panel capacity is to be taken as the compressive stress calculated at load calculation points of the stiffener attached plating, as defined in applicable Rules.
- For grillage analysis where the stresses are obtained based on the beam theory, the following values:

$$\sigma_x = \frac{\sigma_{xb} + \nu \sigma_{yb}}{1 - \nu^2}$$

$$\sigma_y = \frac{\sigma_{yb} + \nu \sigma_{xb}}{1 - \nu^2}$$

where:

- σ_{xb} , σ_{yb} : Stresses, in N/mm², from grillage beam analysis, respectively along x axis and y axis of the plate attached to the PSM.

The shear stress τ , in N/mm², to be applied for the overall stiffened panel capacity and the plate panel capacity calculations, as given in [2.1.1] and [2.2.1] respectively, is to be taken as follows:

- for FE analysis, the reference shear stresses as defined in Sec 4, [2.4]
- for prescriptive assessment of the plate panel capacity, the shear stresses at load calculation points of the considered elementary plate panel, as defined in the applicable Rules
- for prescriptive assessment of the overall stiffened panel capacity, the shear stresses calculated according to Sec 3, [2.1.1], at the following load calculation point:
 - at the middle of the full span, ℓ , of the considered stiffener
 - at the intersection point between the stiffener and its attached plating
- for grillage beam analysis, $\tau = 0$ in the plate attached to the PSM.

2.3 Stiffeners

2.3.1 Buckling modes

The following buckling modes are to be checked:

- stiffener induced failure (SI)
- associated plate induced failure (PI).

2.3.2 Idealisation of bulb bars

Bulb bars are to be considered as equivalent angle bars, as defined in the applicable Rules.

2.3.3 Ultimate buckling capacity

When $\sigma_a + \sigma_b + \sigma_w > 0$ while initially setting $\gamma = 1$, the ultimate buckling capacity for stiffeners is to be checked according to the following interaction formula:

$$\frac{\gamma_c \sigma_a + \sigma_b + \sigma_w}{R_{eH}} S = 1$$

where:

- σ_a : Effective axial stress, in N/mm², at mid span of the stiffener, acting on the stiffener with its attached plating:

$$\sigma_a = \sigma_{x1} \frac{s t_p + A_{s_eff}}{b_{eff1} t_p + A_{s_eff}}$$

- σ_{x1} : Nominal axial stress, in N/mm², acting on the stiffener with its attached plating:
- for FE analysis, σ_{x1} is the FE corrected stress, as defined in [2.3.5], in the attached plating in the direction of the stiffener axis
 - for prescriptive assessment, σ_{x1} is the axial stress at load calculation point of the stiffener, as defined in the applicable Rules
 - for grillage beam analysis, σ_{x1} is the stress acting along the x axis of the attached buckling panel
- R_{eH} : Specified minimum yield stress of the material, in N/mm²:
- for stiffener induced failure (SI): $R_{eH} = R_{eH,S}$
 - for associated plate induced failure (PI): $R_{eH} = R_{eH,P}$
- σ_b : Bending stress in the stiffener, in N/mm²:
- $$\sigma_b = \frac{M_0 + M_1 + M_2}{1000Z_{eff}}$$
- M_2 : Bending moment, in N.mm, due to eccentricity of sniped stiffeners, to be taken as:
- $M_2 = 0$ for continuous stiffeners
 - $M_2 = C_{snip}W_{na} \gamma \sigma_{x1} (A_p + A_{s,eff})$ for stiffeners sniped at one or both ends.
with σ_{x1} not taken less than 0.
- C_{snip} : Coefficient to account for the end effect of the stiffener sniped at one or both ends, to be taken as:
- $C_{snip} = -1,2$ for stiffener induced failure (SI)
 - $C_{snip} = 1,2$ for plate induced failure (PI)
- C_{sl} : Deformation reduction factor to account for global slenderness, to be taken as:
- For $\lambda_G \leq 1,56$
$$C_{sl} = 1 - \frac{1}{12} \lambda_G^4$$
 - For $\lambda_G > 1,56$
$$C_{sl} = \frac{3}{\lambda_G^4}$$
- λ_G : The reference degree of global slenderness of the stiffened panel, to be taken as:
- $$\lambda_G = \sqrt[4]{\frac{\gamma_{ReH}}{\gamma_{GEB}}}$$
- $$\gamma_{ReH} = \frac{\min(R_{eH,P}, R_{eH,S})}{\sqrt{\sigma_{x,av}^2 + \sigma_y^2 - \sigma_{x,av} \sigma_y + 3 \tau_{xy}^2}}$$
- Z_{eff} : Net section modulus of the stiffener, in cm³, including effective width of the attached plating according to [2.3.4] and considering reduced web thickness $t_{w,red}$ in case of flat bars, to be taken as:
- the section modulus calculated at the top of the stiffener flange for stiffener induced failure (SI)
 - the section modulus calculated at the attached plating for associated plate induced failure (PI)
- C_{PI} : Associated plate induced failure pressure coefficient:
- $C_{PI} = 1$ if the lateral pressure is applied on the side opposite to the stiffener
 - $C_{PI} = -1$ if the lateral pressure is applied on the same side as the stiffener
- C_{SI} : Stiffener induced failure pressure coefficient:
- $C_{SI} = -1$ if the lateral pressure is applied on the side opposite to the stiffener
 - $C_{SI} = 1$ if the lateral pressure is applied on the same side as the stiffener
- M_1 : Bending moment, in N.mm, induced by:
- lateral pressure P:
 - for continuous stiffener:
$$M_1 = C_i \frac{|P|s \ell^2}{24 \cdot 10^3}$$
 - for sniped stiffener:
$$M_1 = C_i \frac{|P|s \ell^2}{8 \cdot 10^3}$$
 - for sniped stiffener at one end and continuous at the other end:
$$M_1 = C_i \frac{|P|s \ell^2}{14,2 \cdot 10^3}$$

- concentrated forces:

$$M_1 = C_{CL}|M_{CL}|10^6$$

P : Lateral pressure, in kN/m²:

- for FE analysis, P is the average pressure P_{avr} as defined in Sec 4, [2.5.2] in the attached plating
- for prescriptive assessment, P is the pressure calculated at load calculation point of the stiffener, as defined in the applicable Rules

C_{CL} : Concentrated load coefficient:

- for stiffener induced failure (SI): $C_{CL} = -1$
- for associated plate induced failure (PI): $C_{CL} = 1$

C_i : Pressure coefficient:

- for stiffener induced failure (SI): $C_i = C_{Si}$
- for associated plate induced failure (PI): $C_i = C_{Pi}$

M_{CL} : Bending moment, in kN.m, taken as the maximum bending moment in absolute value induced by the concentrated load in the area between $\ell/3$ and $2\ell/3$ of the stiffener span

This bending moment may be evaluated by means of beam analysis, taking into account the condition of fixity at the ends of the stiffener

M_0 : Bending moment, in N-mm, due to the lateral deformation w_0 of the stiffener:

$$M_0 = F_E \cdot C_{s1} \frac{\gamma}{\gamma_{GEB} - \gamma} w_0$$

with precondition $\gamma_{GEB} - \gamma > 0$

where γ_{GEB} is the stress multiplier factor of global elastic buckling capacity as defined in [2.1].

F_E : Ideal elastic buckling force of the stiffener, in N:

$$F_E = \left(\frac{\pi}{\ell}\right)^2 E I_{eff} 10^4$$

t_p : Net thickness of the attached plating, in mm, to be taken as:

- for prescriptive requirements: the mean thickness of the two attached plating panels
- for FE analysis: the thickness of the considered EPP on one side of the stiffener

w_0 : Assumed imperfection, in mm, to be taken as: $w_0 = \ell / 1000$

w_{nat} : Distance, in mm, from the mid-point of attached plating to the neutral axis of the stiffener calculated with the effective width of the attached plating according to [2.3.4]

σ_w : Stress due to torsional deformation, in N/mm², to be taken as:

- For stiffener induced failure (SI):
 - for $\sigma_a > 0$:

$$\sigma_w = E y_w e_1 \Phi_0 \left(\frac{m_{tor} \pi}{\ell_{tor}}\right)^2 \left(\frac{1}{1 - \frac{\gamma \sigma_a}{\sigma_{ET}}} - 1\right) \quad \text{with precondition } \sigma_{ET} - \gamma \sigma_a > 0$$

- for $\sigma_a \leq 0$:

$$\sigma_w = 0$$

- For plate induced failure (PI):

$$\sigma_w = 0$$

y_w : Distance, in mm, from the centroid of the stiffener cross-section to the free edge of the stiffener flange, to be taken as:

- for flat bars:

$$y_w = \frac{t_w}{2}$$

- for angle and bulb bars:

$$y_w = b_f - \frac{h_w t_w^2 + t_f b_f^2}{2A_s}$$

- for T-bars:

$$y_w = \frac{b_f}{2}$$

- for L2 bars:

$$y_w = b_{f-out} + 0,5 t_w - \frac{h_w t_w^2 + t_f (b_f^2 - 2 b_f d_f)}{2A_s}$$

- ℓ_{tor} : Stiffener span, in mm, taken equal to spacing between primary supporting members, i.e. $\ell_{tor} = \ell$. When the stiffener is supported by tripping brackets, ℓ_{tor} should be taken as the maximum spacing between the adjacent primary supporting members and fitted tripping brackets
- Φ_0 : Coefficient taken as:
- $$\Phi_0 = \frac{\ell_{tor}}{m_{tor} h_w} 10^{-4}$$
- σ_{ET} : Reference stress for torsional buckling, in N/mm²:
- $$\sigma_{ET} = \frac{E}{I_p} \left[\left(\frac{m_{tor} \pi}{\ell_{tor}} \right)^2 I_w \cdot 10^2 + \frac{1}{2(1+\nu)} I_T + \left(\frac{\ell_{tor}}{m_{tor} \pi} \right)^2 \varepsilon \cdot 10^{-4} \right]$$
- I_p : Net polar moment of inertia of the stiffener, in cm⁴, about point C (see Fig 1), as defined in Tab 6
- I_T : Net Saint Venant's moment of inertia of the stiffener, in cm⁴, as defined in Tab 6
- I_ω : Net sectorial moment of inertia of the stiffener, in cm⁶, about point C (see Fig 1), as defined in Tab 6
- m_{tor} : Number of half waves within ℓ_{tor} , taken as a positive integer so as to give smallest reference stress for torsional buckling
- ε : Degree of fixation, in mm², to be taken as:
- for bulb, angle, L2, L3 and T profiles:
- $$\varepsilon = \left(\frac{3b}{t_p^3} + \frac{2h_w}{t_w^3} \right)^{-1}$$
- for flat bars:
- $$\varepsilon = \left(\frac{t_p^3}{3b} \right)$$
- A_w : Net area of the stiffener web, in mm²
- A_f : Net area of the stiffener flange, in mm².

Table 6 : Moments of inertia I_p , I_T and I_ω

Flat bars (1)	Bulb, angle, L2 and T-bars
$I_p = \frac{h_w^3 t_w}{3 \cdot 10^4}$	$I_p = \left(\frac{A_w (e_f - 0,5 t_f)^2}{3} + A_f e_f^2 \right) 10^{-4}$
$I_T = \frac{h_w t_w^3}{3 \cdot 10^4} \left(1 - 0,63 \frac{t_w}{h_w} \right)$	$I_T = \frac{(e_f - 0,5 t_f) t_w^3}{3 \cdot 10^4} \left(1 - 0,63 \frac{t_w}{e_f - 0,5 t_f} \right) + \frac{b_f t_f^3}{3 \cdot 10^4} \left(1 - 0,63 \frac{t_f}{b_f} \right)$
$I_\omega = \frac{h_w^3 t_w^3}{36 \cdot 10^6}$	<ul style="list-style-type: none"> for bulb, angle and L2 bars (2): $I_\omega = \frac{A_f^3 + A_w^3}{36 \cdot 10^6} + \frac{e_f^2}{10^6} \left(\frac{A_f b_f^2 + A_w t_w^2}{3} - \frac{(A_f (b_f - 2 d_f) + A_w t_w)^2}{4(A_f + A_w)} - A_f d_f (b_f - d_f) \right)$
	<ul style="list-style-type: none"> for T-bars: $I_\omega = \frac{b_f^3 t_f e_f^2}{12 \cdot 10^6}$
(1) $t_{w,red}$ is not to be used in this Table.	
(2) d_f is to be taken as 0 for bulb and angle profiles.	

2.3.4 Effective width of attached plating

The effective width b_{eff} , in mm, of the stiffener attached plating is to be taken as:

- when $\sigma_x > 0$:
 - for FE analysis:

$$b_{eff} = \text{Min} (C_x b ; \chi_s s)$$
 - for prescriptive assessment:

$$b_{eff} = \text{Min} \left(\frac{C_{x1} b_1 + C_{x2} b_2}{2} ; \chi_s s \right)$$
- when $\sigma_x \leq 0$:

$$b_{eff} = \chi_s s$$

where:

χ_s : Effective width coefficient to be taken as:

- for $l_{eff}/s \geq 1$:

$$\chi_s = \text{Min} \left[\frac{1,12}{1 + \frac{1,75}{\left(\frac{l_{eff}}{s}\right)^{1,6}}}; 1, 0 \right]$$

- for $l_{eff}/s < 1$:

$$\chi_s = 0,407 \frac{l_{eff}}{s}$$

l_{eff} : Effective length of the stiffener, in mm, taken as:

- for a stiffener fixed at both ends:

$$l_{eff} = \frac{l}{\sqrt{3}}$$

- for a stiffener simply supported at one end and fixed at the other:

$$l_{eff} = 0,75 l$$

- for a stiffener simply supported at both ends:

$$l_{eff} = l$$

2.3.5 FE corrected stresses for stiffener capacity

When the reference stresses σ_x and σ_y obtained by FE analysis according to Sec 4, [2.4] are both compressive, σ_x is to be corrected according to the following formula:

- if $\sigma_x < \nu \sigma_y$: $\sigma_{xcor} = 0$
- if $\sigma_x \geq \nu \sigma_y$: $\sigma_{xcor} = \sigma_x - \nu \sigma_y$

2.4 Primary supporting members

2.4.1 Web plate in way of openings

The web plate of primary supporting members with openings is to be assessed for buckling based on the combined axial compressive and shear stresses.

The web plate adjacent to the opening on both sides is to be considered as individual unstiffened plate panels as shown in Tab 7.

The interaction formulae of [2.2.1] are to be used with:

- $\sigma_x = \sigma_{av}$
- $\sigma_y = 0$
- $\tau = \tau_{av}$

where:

σ_{av} : Weighted average compressive stress, in N/mm², in the area of web plate being considered, i.e. P1, P2 or P3 as shown in Tab 7

τ_{av} : Weighted average shear stress, in N/mm²:

- for opening modelled in primary supporting members:

τ_{av} is the weighted average shear stress in the area of web plate being considered, i.e. P1, P2 or P3 as shown in Tab 7

- for opening not modelled in primary supporting members:

τ_{av} is the weighted average shear stress given in Tab 7.

2.4.2 Reduction factors of web plate in way of openings

The reduction factors, C_x or C_y in combination with C_τ , of the plate panel(s) of the web adjacent to the opening is to be taken as shown in Tab 7.

Table 7 : Reduction factors C_x , C_y and C_τ

Configuration (1)	C_x and C_y	C_τ	
		Opening modelled in PSM	Opening not modelled in PSM
<p>(a) Without edge reinforcements (2):</p>	<p>Separate reduction factors are to be applied to areas P1 and P2 using case 3 or case 6 in Tab 4, with edge stress ratio $\psi = 1,0$</p>	<p>Separate reduction factors are to be applied to areas P1 and P2 using case 18 or case 19 in Tab 4</p>	<ul style="list-style-type: none"> when case 17 of Tab 4 is applicable: A common reduction factor is to be applied to areas P1 and P2 using case 17 in Tab 4 with: $\tau_{av} = \tau_{av}(\text{web})$ when case 17 of Tab 4 is not applicable: Separate reduction factors are to be applied to areas P1 and P2 using case 18 or case 19 in Tab 4 with: $\tau_{av} = \frac{\tau_{av}(\text{web}) \cdot h}{h - h_o}$
<p>(b) With edge reinforcements:</p>	<p>Separate reduction factors are to be applied to areas P1 and P2 using, in Tab 4 C_x for case 1 or C_y for case 2, with edge stress ratio $\psi = 1,0$</p>	<p>Separate reduction factors are to be applied to areas P1 and P2 using case 15 in Tab 4</p>	<p>Separate reduction factors are to be applied to areas P1 and P2 using case 15 in Tab 4, with: $\tau_{av} = \frac{\tau_{av}(\text{web}) \cdot h}{h - h_o}$</p>
<p>(c) Example of hole in web:</p>		<p>Panels P1 and P2 are to be evaluated in accordance with configuration (a) Panel P3 is to be evaluated in accordance with configuration (b)</p>	

where:

h : Height, in m, of the web of the primary supporting member in way of the opening

h_o : Height, in m, of the opening measured in the depth of the web

$\tau_{av}(\text{web})$: Weighted average shear stress, in N/mm^2 over the web height h of the primary supporting member.

(1) Web panels to be considered for buckling in way of openings are shown shaded and numbered P1, P2, etc.

(2) For a PSM web panel with opening and without edge reinforcements as shown in configuration (a), the applicable buckling assessment method depends on the boundary conditions of its individual long edges:

- If the structure adjacent to the panel can provide in-plane support to the panel, i.e. the edge cannot pull in, Method A is to be applied (typically when long edges are attached to PSM web stiffeners).
- In other cases, where no structure adjacent to the panel can provide in-plane support to the panel, i.e. the edge is free to pull in, Method B is to be applied (typically when the long edges are attached to the PSM attached plating and flange).

2.4.3 The equivalent plate panel of web plate of primary supporting members crossed by perpendicular stiffeners is to be idealised as shown in Fig 3.

Figure 3 : Web plate idealisation

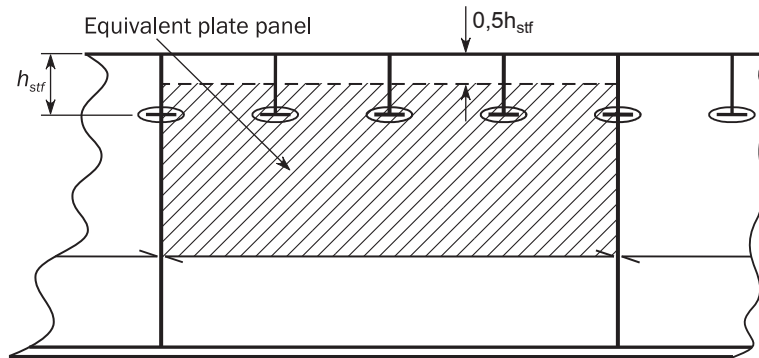

The correction of panel breadth is also applicable for other slot configurations, provided the web or the collar plate is attached to at least one side of the passing stiffener.

2.5 Stiffened Panels with U-type Stiffeners

2.5.1 Local plate buckling

For stiffened panels with U-type stiffeners, local plate buckling is to be checked for each of the plate panels EPP b_1 , b_2 , b_f and h_w (see Fig 2) separately as follows:

- The attached plate panels EPP b_1 and b_2 are to be assessed using SP-A model, where in the calculation of buckling factors K_x as defined in Case 1 of Tab 4, the correction factor F_{long} for U-type stiffeners as defined in Tab 3 is to be used; and in the calculation of K_y as defined in Case 2 of Tab 4, the F_{trans} for U-type stiffeners as defined in [2.2.5] is to be used.
- The face plate and web plate panels b_f and h_w are to be assessed using UP-B model with $F_{long} = 1$ and $F_{trans} = 1$.

2.5.2 Overall stiffened panel buckling and stiffener buckling

For a stiffened panel with U-type stiffeners, the overall buckling capacity and ultimate capacity of the stiffeners are to be checked with warping stress $\sigma_w = 0$, and with bending moment of inertia including effective width of attached plating being calculated based on the following assumptions:

- The two web panels of a U-type stiffener are to be taken as perpendicular to the attached plate with thickness equal to t_w and height equal to the distance between the attached plate and the face plate of the stiffener.
- Effective width of the attached plating, b_{eff} taken as the sum of the b_{eff} calculated for the EPP b_1 and b_2 respectively according to SP-A model.
- Effective width of the attached plating of a stiffener without shear lag effect, b_{eff1} , taken as the sum of the b_{eff1} calculated for the EPP b_1 and b_2 respectively.

3 Buckling capacity of the other structures

3.1 Struts, pillars and cross ties

3.1.1 Buckling utilisation factor

The buckling utilisation factor η , for axially compressed struts, pillars and cross ties, is to be taken as:

$$\eta = \frac{\sigma_{av}}{\sigma_{cr}}$$

where:

σ_{av} : Average axial compressive stress in the member, in N/mm²

σ_{cr} : Minimum critical buckling stress, in N/mm², taken as:

- for $\sigma_E \leq 0,5 R_{eH,S}$:

$$\sigma_{cr} = \sigma_E$$

- for $\sigma_E > 0,5 R_{eH,S}$:

$$\sigma_{cr} = \left(1 - \frac{R_{eH,S}}{4\sigma_E}\right) R_{eH,S}$$

σ_E : Minimum elastic buckling stress, in N/mm², according to [3.1.3] to [3.1.5], as applicable.

$R_{eH,S}$: Specified minimum yield stress of the considered member, in N/mm². For built-up members, the lowest specified minimum yield stress is to be used.

3.1.2 Elastic column buckling stress

The elastic compressive column buckling stress σ_{EC} , in N/mm², of members subject to axial compression is to be taken as:

$$\sigma_{EC} = \pi^2 E f_{end} \frac{I}{A \ell_{pill}^2} 10^{-4}$$

where:

- A : Net cross-sectional area of the member, in cm²
- I : Net moment of inertia about the weakest axis of the cross-section, in cm⁴
- ℓ_{pill} : Length of the member, in m:
 - for pillars and struts:
 - ℓ_{pill} is the unsupported length of the member
 - for cross ties:
 - in centre tanks: ℓ_{pill} is the distance between the flanges of longitudinal stiffeners on the starboard and port longitudinal bulkheads to which the cross tie's horizontal stringer is attached
 - in wing tanks: ℓ_{pill} is the distance between the flanges of longitudinal stiffeners on the longitudinal bulkhead to which the cross tie's horizontal stringer is attached, and the inner hull plating.
- f_{end} : End constraint factor, taken as:
 - for pillars and struts:
 - $f_{end} = 1,0$ where both ends are simply supported
 - $f_{end} = 2,0$ where one end is simply supported and the other end is fixed
 - $f_{end} = 4,0$ where both ends are fixed
 - for cross ties:
 - $f_{end} = 2,0$

A pillar end may be considered fixed when brackets of adequate size are fitted. Such brackets are to be supported by structural members with bending stiffness greater than the pillar.

3.1.3 Elastic torsional buckling stress of open-type cross-sections

The elastic torsional buckling stress σ_{ET} , in N/mm², with respect to axial compression of members is to be taken as:

$$\sigma_{ET} = \frac{GI_{sv}}{I_{pol}} + \frac{\pi^2 f_{end} E C_{warp}}{I_{pol} \ell_{pill}^2} 10^{-4}$$

where:

- I_{sv} : Net Saint Venant's moment of inertia, in cm⁴ (see Tab 8 for examples of cross-sections)
- I_{pol} : Net polar moment of inertia about the shear centre of cross-section, in cm⁴, taken as:
 - $I_{pol} = I_y + I_z + A (y_0^2 + z_0^2)$
- C_{warp} : Warping constant, in cm⁶ (see Tab 8 for examples of cross-sections)
- ℓ_{pill} : Length of the member, in m, as defined in [3.1.2]
- I_y : Net moment of inertia about the y axis, in cm⁴
- I_z : Net moment of inertia about the z axis, in cm⁴
- A : Net cross-sectional area of the member, in cm²
- y_0 : Transverse position of shear centre relative to the cross-sectional centroid, in cm (see Tab 8 for examples of cross-sections)
- z_0 : Vertical position of shear centre relative to the cross-sectional centroid, in cm (see Tab 8 for examples of cross-sections).

3.1.4 Elastic torsional/column buckling stress of open-type cross-sections

For the cross-sections where the centroid and the shear centre do not coincide, the interaction between the torsional and column buckling modes is to be examined.

The elastic torsional/column buckling stress σ_{ETF} , in N/mm², with respect to axial compression is to be taken as:

$$\sigma_{ETF} = \frac{1}{2\zeta} [(\sigma_{EC} + \sigma_{ET}) - \sqrt{(\sigma_{EC} + \sigma_{ET})^2 - 4\zeta \sigma_{EC} \sigma_{ET}}]$$

where:

- σ_{EC} : Elastic compressive column buckling stress, as defined in [3.1.2]
- σ_{ET} : Elastic torsional buckling stress, as defined in [3.1.3]
- ζ : Coefficient taken as:

$$\zeta = 1 - \frac{(y_0^2 + z_0^2) A}{I_{pol}}$$

y_0, z_0, I_{pol} : As defined in [3.1.3]

A : Net cross-sectional area of the member, in cm^2 .

3.2 Corrugated bulkheads

3.2.1 The buckling utilisation factor of flange and web of corrugations of corrugated bulkheads is based on the combination of in-plane stresses and shear stress.

The interaction formulae of [2.2.1] are to be used considering the following coefficients:

- $\alpha = 2$
- $\Psi_x = \Psi_y = 1$

Table 8 : Cross-sectional properties

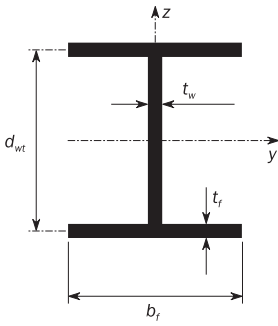
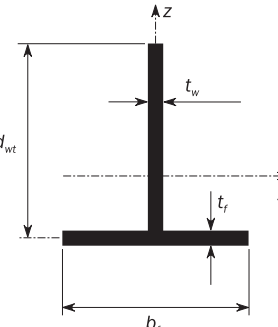
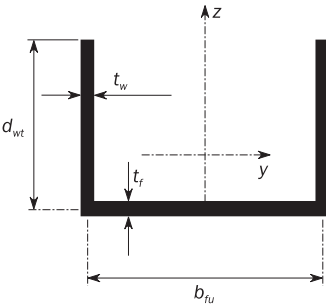
Typical cross-sections	Properties	Units
	$I_{sv} = \frac{1}{3} (2b_f t_f^3 + d_{wt} t_w^3) 10^{-4}$	cm^4
	$C_{warp} = \frac{d_{wt}^2 b_f^3 t_f}{24} 10^{-6}$	cm^6
	$I_{sv} = \frac{1}{3} (b_f t_f^3 + d_{wt} t_w^3) 10^{-4}$	cm^4
	$y_0 = 0$	cm
	$z_0 = -\frac{0,5 d_{wt}^2 t_w}{d_{wt} t_w + b_f t_f} 10^{-1}$	cm
	$C_{warp} = \frac{b_f^3 t_f^3 + 4d_{wt}^3 t_w^3}{144} 10^{-6}$	cm^6
	$I_{sv-n50} = \frac{1}{3} (b_{fu} t_f^3 + 2d_{wt} t_w^3) 10^{-4}$	cm^4
	$y_0 = 0$	cm
	$z_0 = -\frac{d_{wt}^2 t_w 10^{-1}}{2d_{wt} t_w + b_{fu} t_f} - \frac{0,5 d_{wt}^2 t_w 10^{-1}}{d_{wt} t_w + b_{fu} t_f / 6}$	cm
	$C_{warp} = \frac{b_{fu}^2 d_{wt}^3 t_w (3d_{wt} t_w + 2b_{fu} t_f)}{12(6d_{wt} t_w + b_{fu} t_f)} 10^{-6}$	cm^6

Note 1: All the dimensions are in mm.

Note 2: Cross-sectional properties for cross-sections other than these typical ones are to be determined by direct calculation.

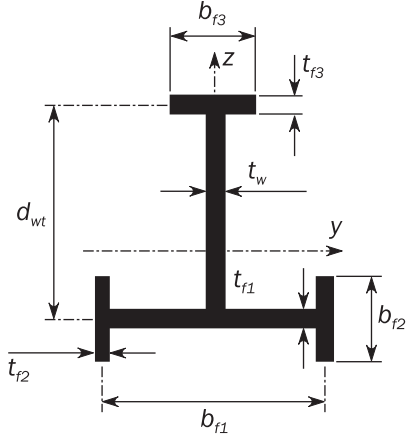
Typical cross-sections	Properties	Units
	$I_{sv} = \frac{1}{3} (b_{f1} t_{f1}^3 + 2b_{f2} t_{f2}^3 + b_{f3} t_{f3}^3 + d_{wt} t_w^3) 10^{-4}$	cm ⁴
	$y_0 = 0$	cm
	$z_0 = z_s - \frac{(b_{f3} d_{wt} t_{f3} + 0,5 d_{wt}^2 t_w) 10^{-1}}{d_{wt} t_w + b_{f1} t_{f1} + 2b_{f2} t_{f2} + b_{f3} t_{f3}}$	cm
	$C_{warp} = \left[I_{f1} z_s^2 + \frac{I_{f2} b_{f2}^2}{200} + I_{f3} \left(\frac{d_{wt}}{10} - z_s \right)^2 \right]$	cm ⁶
	$I_{f1} = \left[\frac{(b_{f1} - t_{f2})^3 t_{f1}}{12} + \frac{b_{f2} t_{f2} b_{f1}^2}{2} \right] 10^{-4}$	cm ⁴
	$I_{f2} = \frac{b_{f2}^3 t_{f2}}{12} 10^{-4}$	cm ⁴
	$I_{f3} = \frac{b_{f3}^3 t_{f3}}{12} 10^{-4}$	cm ⁴
$z_s = \frac{I_{f3} d_{wt}}{I_{f1} + I_{f3}} 10^{-1}$	cm	
<p>Note 1: All the dimensions are in mm.</p> <p>Note 2: Cross-sectional properties for cross-sections other than these typical ones are to be determined by direct calculation.</p>		

Appendix 1 Stress Based Reference Stresses

Symbols

a	: Length, in mm, of the longer side of the plate panel as defined in Sec 5
b	: Length, in mm, of the shorter side of the plate panel as defined in Sec 5
A_i	: Area, in mm ² , of the i-th plate element of the buckling panel
n	: Number of plate elements in the buckling panel
σ_{xi}	: Actual membrane stress, in N/mm ² , at the centroid of the i-th plate element in x direction, applied along the shorter edge of the buckling panel
σ_{yi}	: Actual membrane stress, in N/mm ² , at the centroid of the i-th plate element in y direction, applied along the longer edge of the buckling panel
ψ	: Edge stress ratio as defined in Sec 5
τ_i	: Actual membrane shear stress, in N/mm ² , at the centroid of the i-th plate element of the buckling panel.

1 Stress based method

1.1 Introduction

1.1.1 This Appendix provides a method to determine stress distribution along the edges of the considered buckling panel by 2nd order polynomial curve, by linear distribution using the least square method and by weighted average approach. This method is called Stress based method.

The reference stress is the stress components at centre of the plate element transferred into the local system of the considered buckling panel.

1.1.2 Definition

A regular panel is a plate panel of rectangular shape. An irregular panel is a plate panel which is not regular, as detailed in Sec 4, [2.3.1].

1.2 Stress application

1.2.1 Regular panel

The reference stresses are to be taken as defined in [2.1] for a regular panel when the following conditions are satisfied:

- at least one plate element centre is located in each third part of the long edge a of a regular panel, and
- this element centre is located at a distance in the panel local x direction not less than $a/4$ to at least one of the element centres in the adjacent third part of the panel.

Otherwise, the reference stresses are to be taken as defined in [2.2] for an irregular panel.

1.2.2 Irregular panel and curved panel

The reference stresses of an irregular panel or a curved panel are to be taken as defined in [2.2].

2 Reference stresses

2.1 Regular panel

2.1.1 Longitudinal stress

The longitudinal stress σ_x applied on the shorter edge of the buckling panel is to be calculated as follows:

- for plate buckling assessment, the distribution of $\sigma_x(x)$ is assumed as 2nd order polynomial curve:

$$\sigma_x(x) = Cx^2 + Dx + E$$

The best fitting curve $\sigma_x(x)$ is to be obtained by minimising the square error Π , considering the area of each element as a weighting factor:

$$\Pi = \sum_{i=1}^n A_i [\sigma_{xi} - (Cx_i^2 + Dx_i + E)]^2$$

The unknown coefficients C, D and E must yield zero first partial derivatives $\partial\Pi$ with respect to C, D and E respectively:

$$\begin{cases} \frac{\partial\Pi}{\partial C} = 2 \sum_{i=1}^n A_i x_i^2 [\sigma_{xi} - (Cx_i^2 + Dx_i + E)] = 0 \\ \frac{\partial\Pi}{\partial D} = 2 \sum_{i=1}^n A_i x_i [\sigma_{xi} - (Cx_i^2 + Dx_i + E)] = 0 \\ \frac{\partial\Pi}{\partial E} = 2 \sum_{i=1}^n A_i [\sigma_{xi} - (Cx_i^2 + Dx_i + E)] = 0 \end{cases}$$

The unknown coefficients C, D and E are obtained by solving the three above equations.

$$\sigma_{x1} = \frac{1}{b} \int_0^b \sigma_x(x) dx = \frac{b^2}{3} C + \frac{b}{2} D + E$$

$$\sigma_{x2} = \frac{1}{b} \int_{a-b}^a \sigma_x(x) dx = \left(a^2 - ab + \frac{b^2}{3}\right) C + \left(a - \frac{b}{2}\right) D + E$$

When $(-D/2C < b/2)$ or $(-D/2C > a - b/2)$, σ_{x3} is to be ignored. Otherwise:

$$\sigma_{x3} = \frac{1}{b} \int_{x_{min}}^{x_{max}} \sigma_x(x) dx = \frac{b^2}{12} C - \frac{D^2}{4C} + E$$

where:

$$x_{min} = -\frac{b}{2} - \frac{D}{2C}$$

$$x_{max} = \frac{b}{2} - \frac{D}{2C}$$

The longitudinal stress is to be taken as: $\sigma_x = \text{Max}(\sigma_{x1}; \sigma_{x2}; \sigma_{x3})$

The edge stress ratio is to be taken as: $\psi_x = 1$

- for overall stiffened panel buckling and stiffener buckling assessments, $\sigma_x(x)$ applied on the shorter edge of the attached plate is to be taken as:

$$\sigma_x = \frac{\sum_{i=1}^n A_i \sigma_{xi}}{\sum_{i=1}^n A_i}$$

The edge stress ratio ψ_x for the stress σ_x is equal to 1,0.

2.1.2 Transverse stress

The transverse stress σ_y applied along the longer edges of the buckling panel is to be calculated by extrapolation of the transverse stresses of all the elements up to the shorter edges of the considered buckling panel.

The distribution of $\sigma_y(x)$ is assumed to be a straight line.

Therefore: $\sigma_y(x) = A + B x$

The best fitting curve $\sigma_y(x)$ is to be obtained by the least square method minimising the square error Π , considering the area of each element as a weighting factor:

$$\Pi = \sum_{i=1}^n A_i [\sigma_{yi} - (A + Bx_i)]^2$$

The unknown coefficients A and B must yield zero first partial derivatives $\partial\Pi$ with respect to A and B respectively:

$$\begin{cases} \frac{\partial\Pi}{\partial A} = 2 \sum_{i=1}^n A_i [\sigma_{yi} - (A + Bx_i)] = 0 \\ \frac{\partial\Pi}{\partial B} = 2 \sum_{i=1}^n A_i x_i [\sigma_{yi} - (A + Bx_i)] = 0 \end{cases}$$

The unknown coefficients A and B are obtained by solving the two previous equations, as follows:

$$\left\{ \begin{aligned} A &= \frac{\left(\sum_{i=1}^n A_i \sigma_{yi}\right)\left(\sum_{i=1}^n A_i x_i^2\right) - \left(\sum_{i=1}^n A_i x_i\right)\left(\sum_{i=1}^n A_i x_i \sigma_{yi}\right)}{\left(\sum_{i=1}^n A_i\right)\left(\sum_{i=1}^n A_i x_i^2\right) - \left(\sum_{i=1}^n A_i x_i\right)^2} \\ B &= \frac{\left(\sum_{i=1}^n A_i\right)\left(\sum_{i=1}^n A_i x_i \sigma_{yi}\right) - \left(\sum_{i=1}^n A_i x_i\right)\left(\sum_{i=1}^n A_i \sigma_{yi}\right)}{\left(\sum_{i=1}^n A_i\right)\left(\sum_{i=1}^n A_i x_i^2\right) - \left(\sum_{i=1}^n A_i x_i\right)^2} \end{aligned} \right.$$

$$\sigma_y = \text{Max} (A ; A + Ba)$$

$$\psi_y = \frac{\text{Min} (A; A + Ba)}{\text{Max} (A; A + Ba)} \text{ for } \sigma_y \geq 0$$

$$\psi_y = 1,0 \text{ for } \sigma_y < 0$$

2.1.3 Shear stress

The shear stress τ is to be calculated using a weighted average approach and is to be taken as:

$$\tau = \frac{\sum_{i=1}^n A_i \tau_i}{\sum_{i=1}^n A_i}$$

2.2 Irregular panel and curved panel

2.2.1 Reference stresses

The longitudinal, transverse and shear stresses are to be calculated using a weighted average approach. They are to be taken as:

$$\sigma_x = \frac{\sum_{i=1}^n A_i \sigma_{xi}}{\sum_{i=1}^n A_i} ; \sigma_y = \frac{\sum_{i=1}^n A_i \sigma_{yi}}{\sum_{i=1}^n A_i} ; \tau = \frac{\sum_{i=1}^n A_i \tau_i}{\sum_{i=1}^n A_i}$$

The edge stress ratios are to be taken as follows:

$$\psi_x = 1,0$$

$$\psi_y = 1,0$$

Appendix 2 Method Selection for Direct Strength Analysis of Panels

1 Stiffened and unstiffened panels

1.1 General

1.1.1 This Appendix provides guidance for the selection of the modelling method of plate panels, when assessed for buckling through direct strength analysis according to Sec 4.

1.1.2 The plate panels of hull structure are to be modelled as stiffened or unstiffened panels. Method A or Method B as defined in Sec 1, [2] is to be used according to Fig 1 to Fig 11.

Table 1 : Structural members

Structural elements	Assessment method	Normal panel definition
Longitudinal structure (see Fig 1, Fig 2 and Fig 7)		
Longitudinally stiffened panels Shell envelope Deck Inner hull Hopper tank sides Longitudinal bulkheads	SP-A	length: between web frames width: between primary supporting members
Double bottom longitudinal girders in line with longitudinal bulkheads or connected to hopper tank sides	SP-A	length: between web frames width: full web depth
Web of double bottom longitudinal girders not in line with longitudinal bulkheads or not connected to hopper tank sides	SP-B	length: between web frames width: full web depth
Web of horizontal girders in double side spaces connected to hopper tank sides	SP-A	length: between web frames width: full web depth
Web of horizontal girders in double side spaces not connected to hopper tank sides	SP-B	length: between web frames width: full web depth
Web of single skin longitudinal girders or stringers	UP-B	plate between local stiffeners/face plate/PSM
Transverse structure (see Fig 3 Fig 4, Fig 5, Fig 8 and Fig 11)		
Web of transverse deck frames, including brackets	UP-B	plate between local stiffeners/face plate/PSM
Vertical web in double side spaces	SP-B	length: full web depth width: between primary supporting members
Irregularly stiffened panels, e.g. web panels in way of hopper tanks and bilges	UP-B	plate between local stiffeners/face plate/PSM
Double bottom floors	SP-B	length: full web depth width: between primary supporting members
Vertical web frames, including brackets	UP-B	plate between vertical web stiffeners/face plate/PSM
Cross tie web plates	UP-B	plate between vertical web stiffeners/face plate/PSM
Transverse watertight bulkheads (see Fig 6, Fig 9 and Fig 10)		
Regularly stiffened bulkhead panels including the secondary buckling stiffeners perpendicular to the regular stiffeners (such as carlings)	SP-A	length: between primary supporting members width: between primary supporting members
Irregularly stiffened bulkhead panels, e.g. web panels in way of hopper tanks and bilges	UP-B	plate between local stiffeners/face plate
Web plate of bulkhead stringers, including brackets	UP-B	plate between web stiffeners/face plate
Transverse corrugated bulkheads and cross deck		
Cross deck	SP-A	plate between local stiffeners/PSM

Structural elements	Assessment method	Normal panel definition
Hatch cover top/bottom plating structures		
Hatch cover top/bottom plating	SP-A	length: between transverse girders width: between longitudinal girders
Irregularly stiffened panels	UP-B	plate between local stiffeners/PSM
Hatch cover web panels of primary supporting members		
Web of transverse/longitudinal girder (single skin type)	UP-B	plate between local stiffeners/face plate/PSM
Web of transverse/longitudinal girder (double skin type)	SP-B (1)	length: between PSM width: full web depth
Web panel with opening	Procedure for opening	plate between local stiffeners/face plate/PSM
Irregularly stiffened panels	UP-B	plate between local stiffeners/face plate/PSM
<p>Note 1: SP, UP : Stiffened panel and Unstiffened panel, respectively A, B : Method A and Method B, respectively PSM : Primary supporting member. (1) In case that the buckling carlings/brackets are irregularly arranged in the web of transverse/longitudinal girder, UP-B method may be used.</p>		

Figure 1 : Longitudinal plates for double bottom offshore units

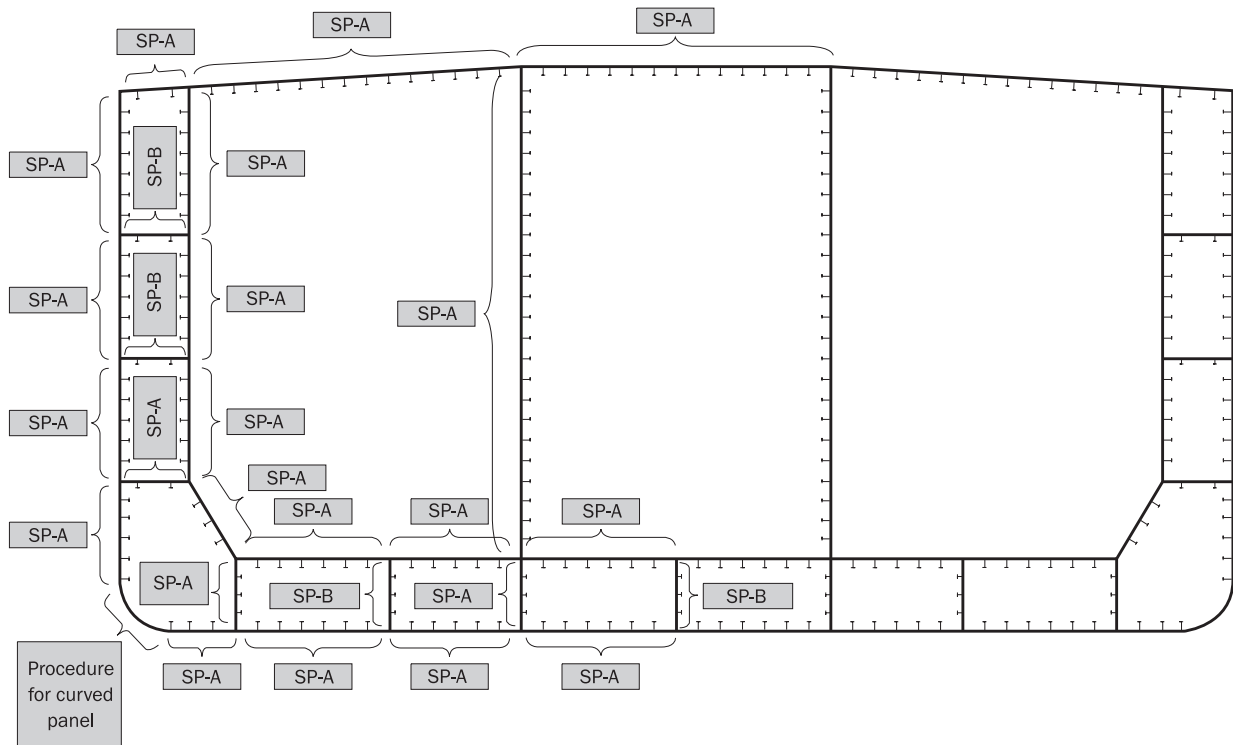

Figure 2 : Longitudinal plates for single bottom offshore units

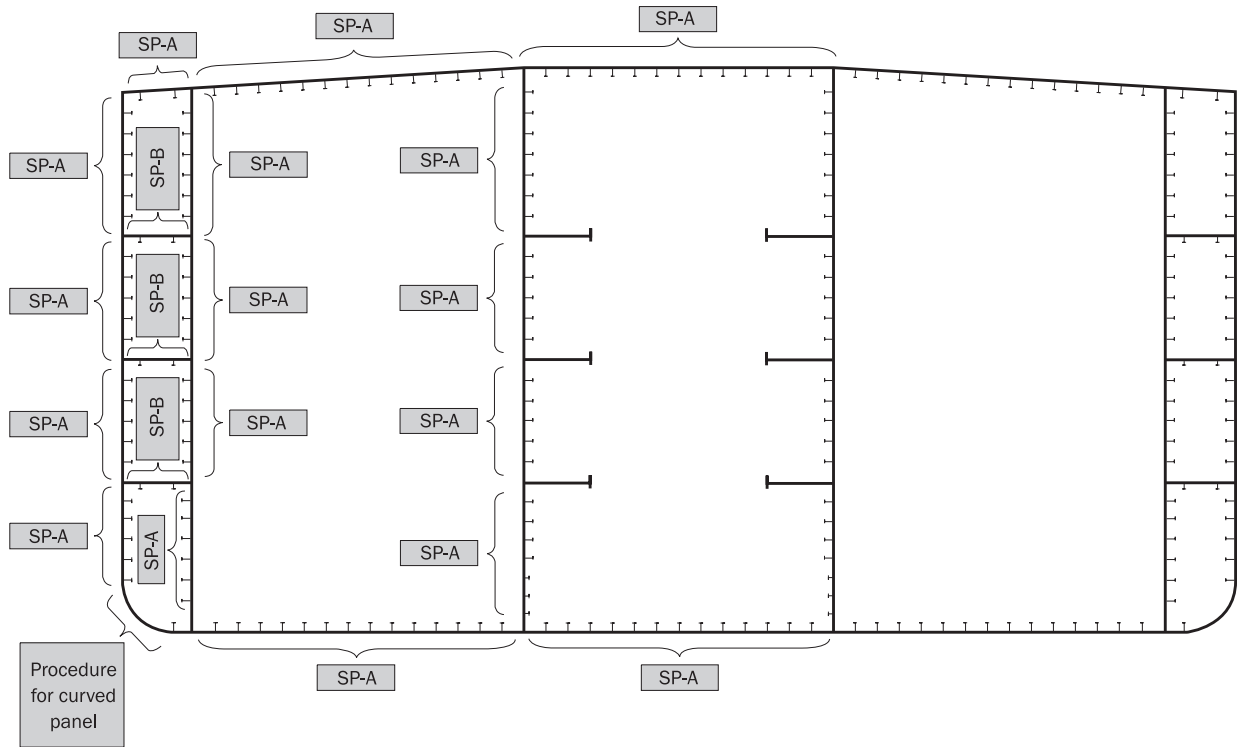

Figure 3 : Transverse web frames for double bottom offshore units

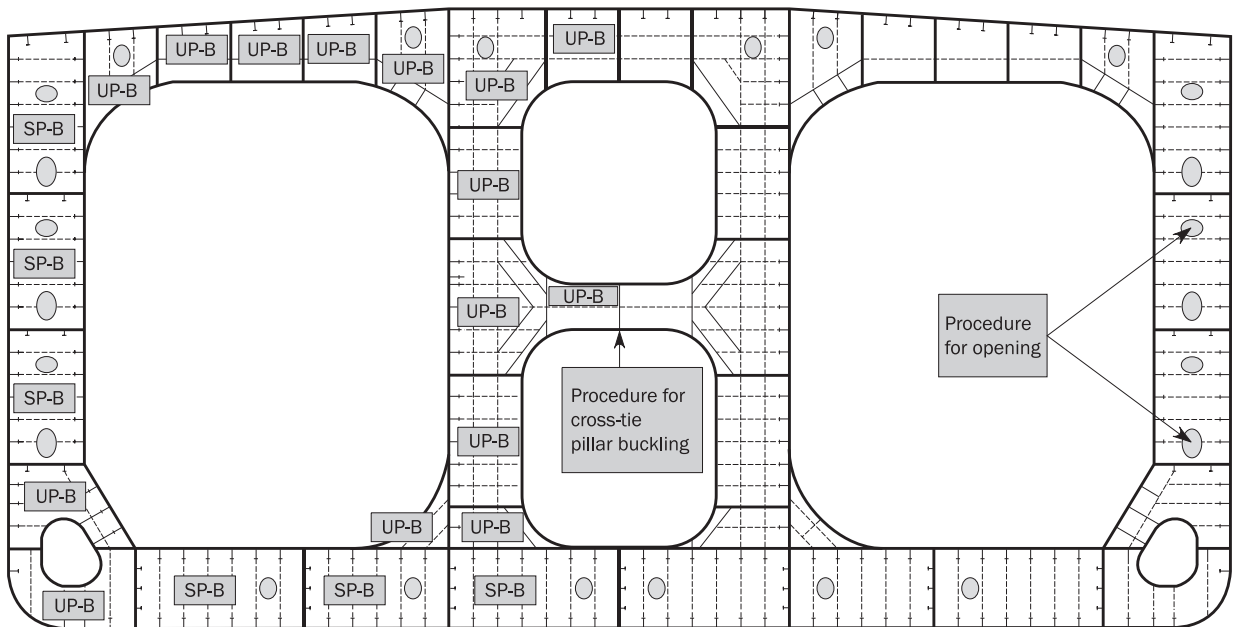

Figure 4 : Transverse web frames for single bottom offshore units

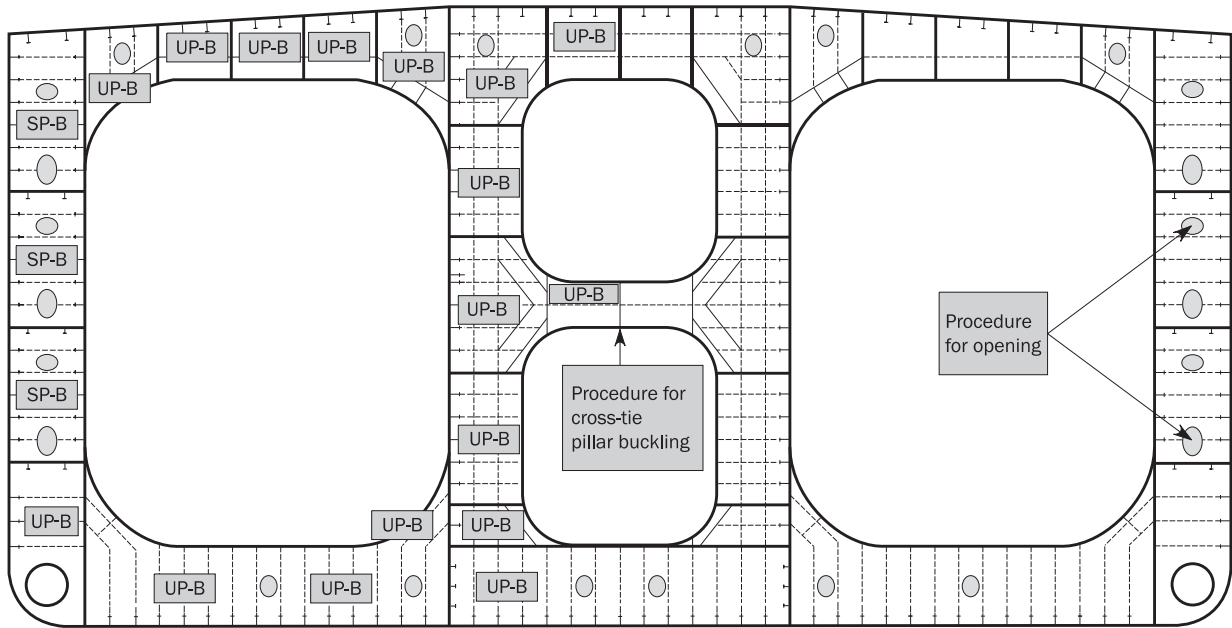

Figure 5 : Cross tie

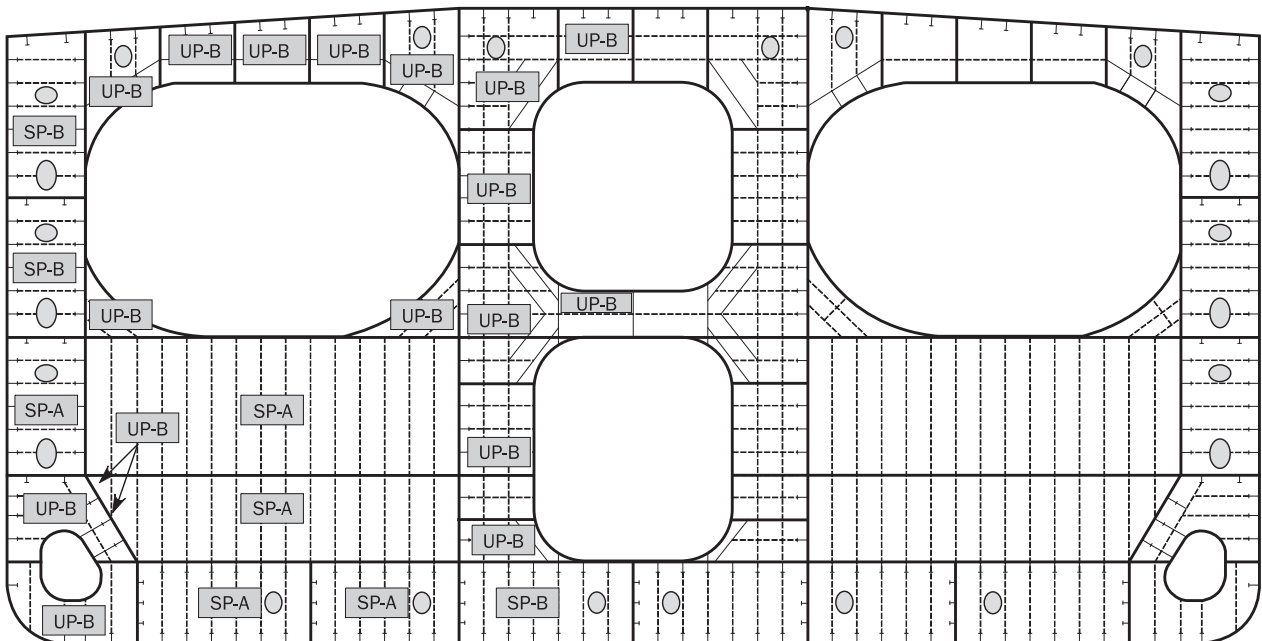

Figure 6 : Transverse bulkhead for offshore units

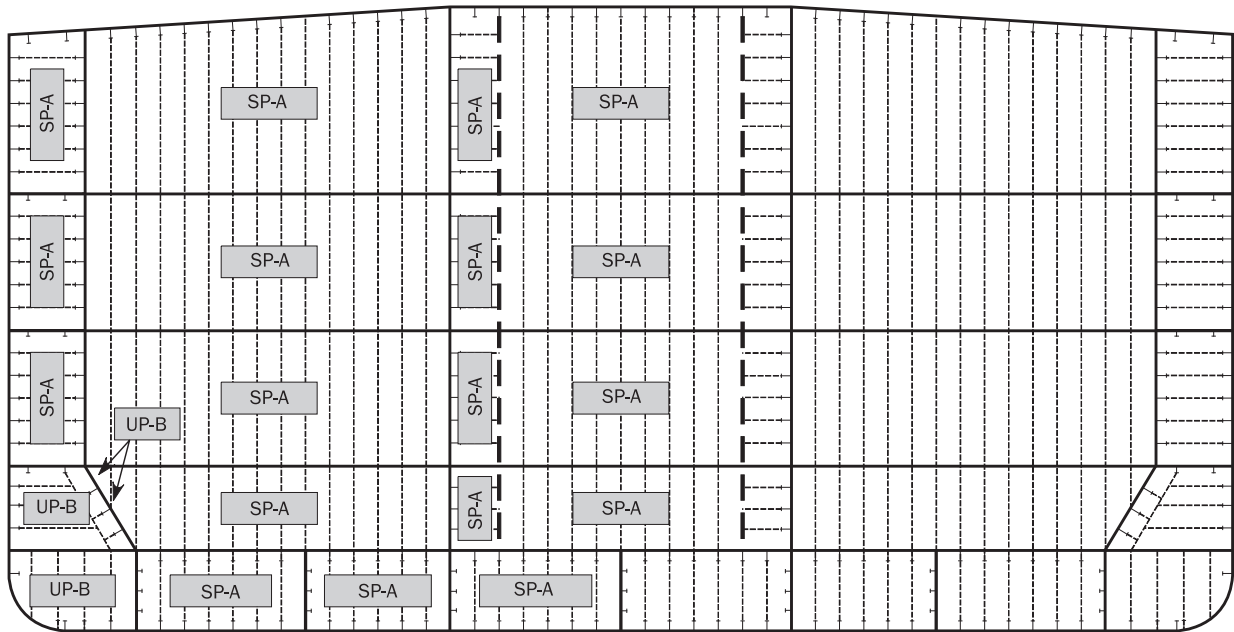

Figure 7 : Longitudinal plates for container ships

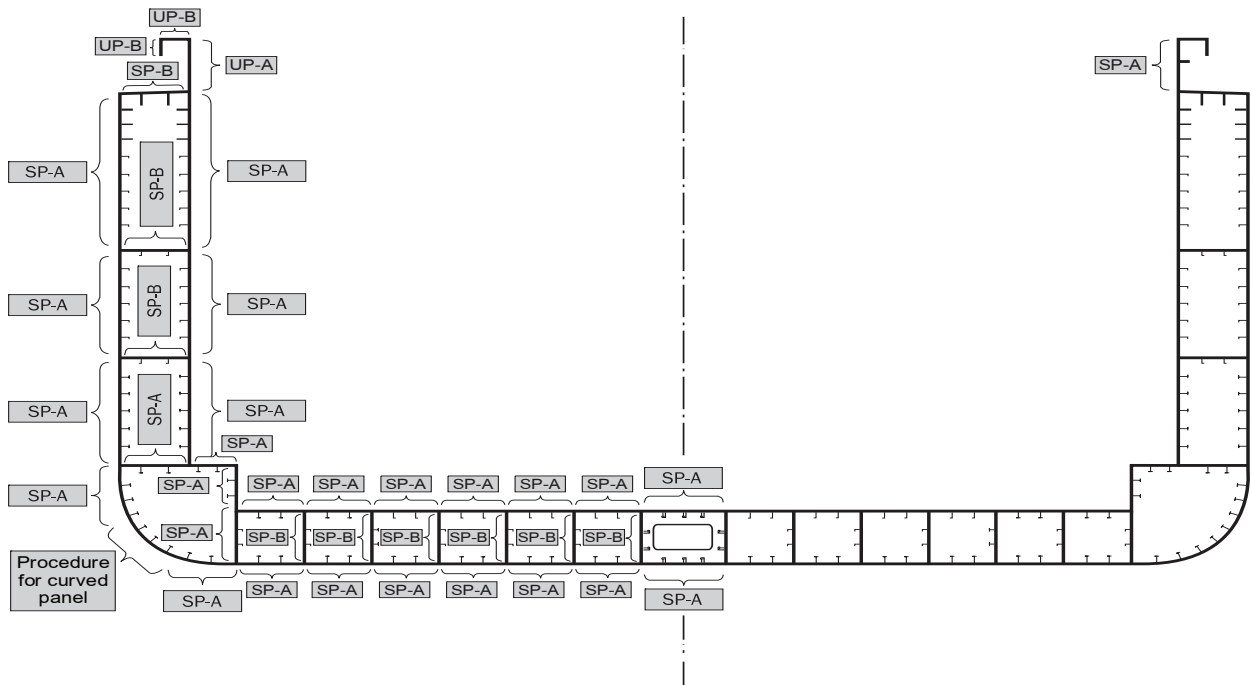

Figure 8 : Transverse web frames for container ships

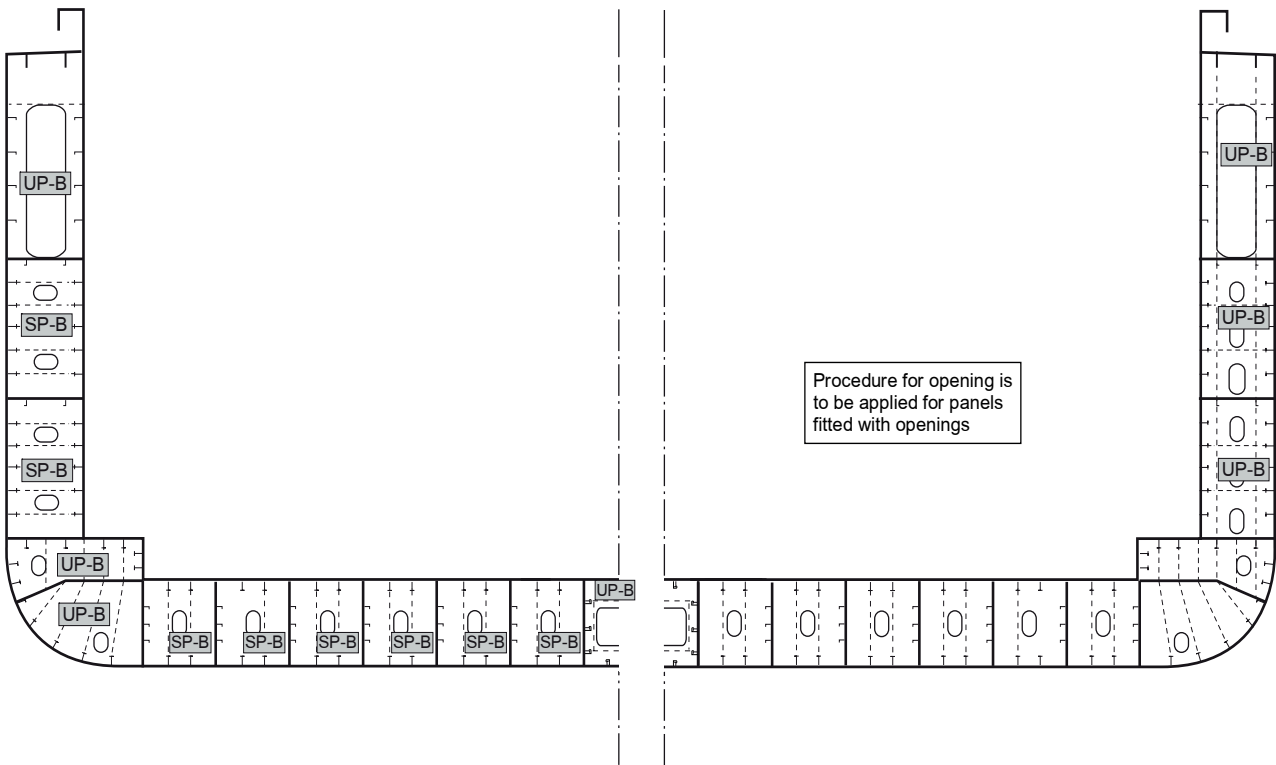

Figure 9 : Transverse bulkhead for container ships

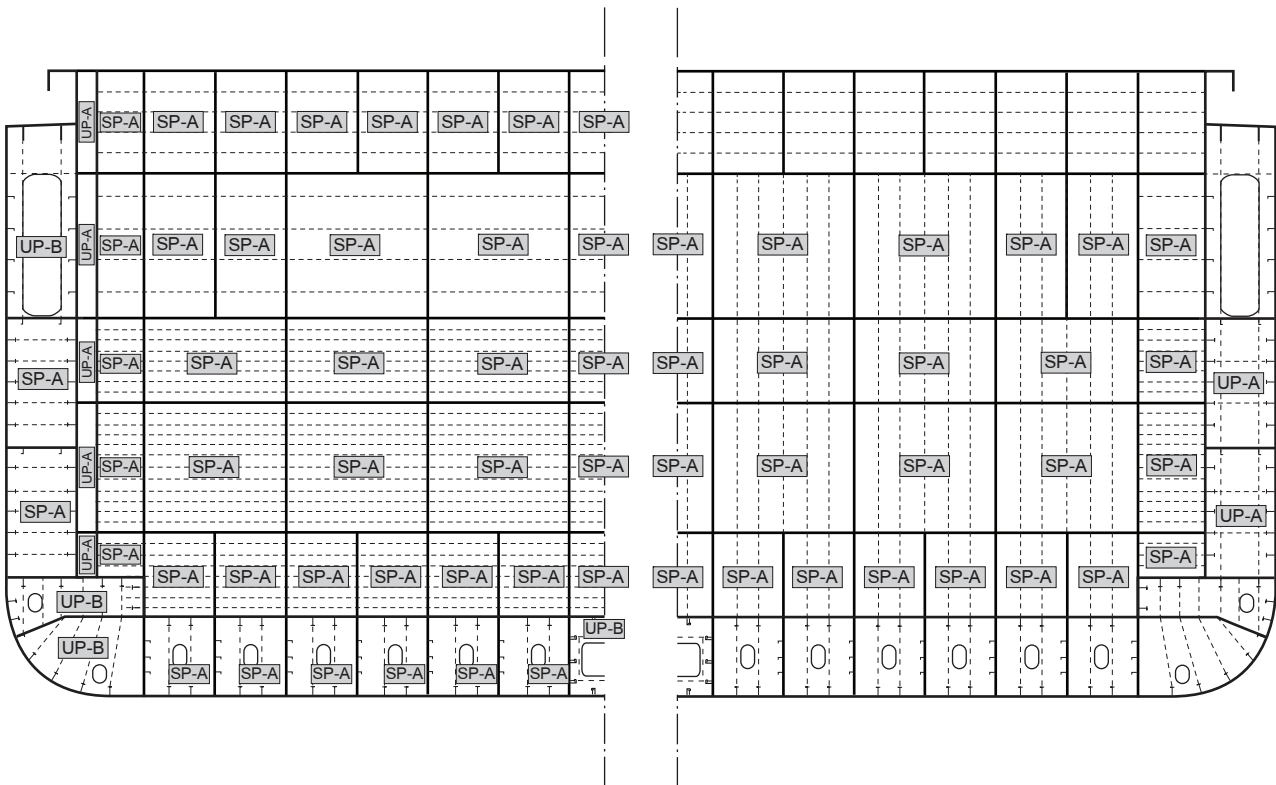

Figure 10 : Bulkhead internal members for container ships

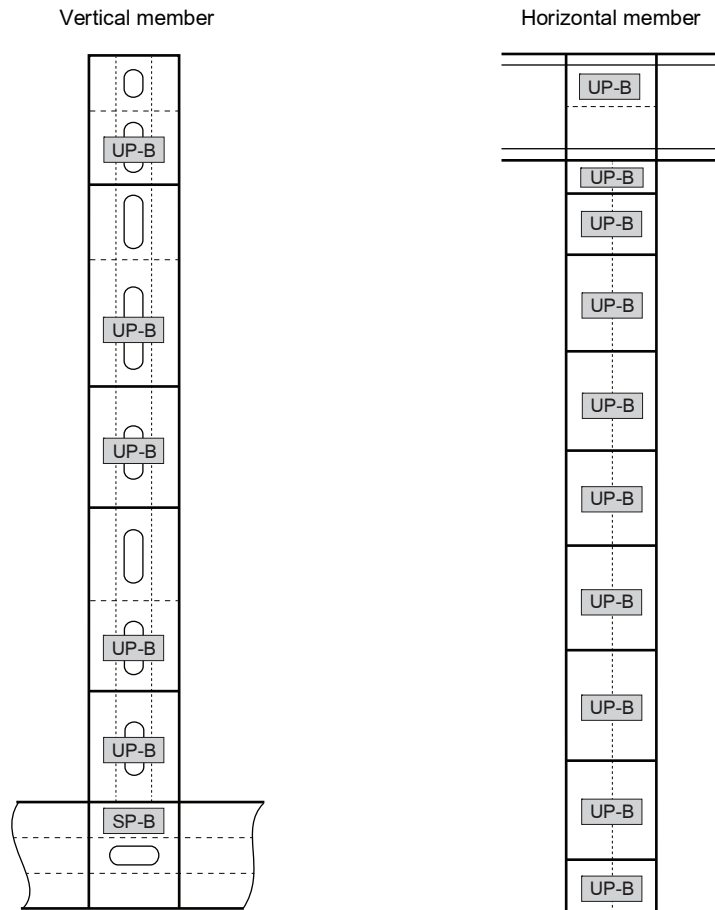
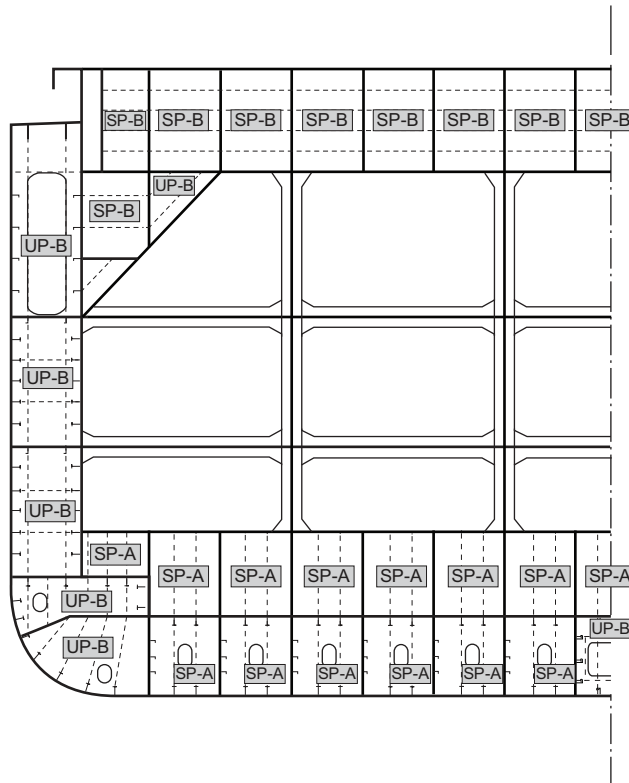

Figure 11 : Support bulkhead for container ships





BUREAU VERITAS MARINE & OFFSHORE

Tour Alto
4 place des Saisons
92400 Courbevoie - France
+33 (0)1 55 24 70 00

marine-offshore.bureauveritas.com/rules-guidelines

© 2026 BUREAU VERITAS - All rights reserved



**BUREAU
VERITAS**

Shaping a World of Trust