

WIND PROPULSION SYSTEMS

NR206 R04

EDITION JULY 2026

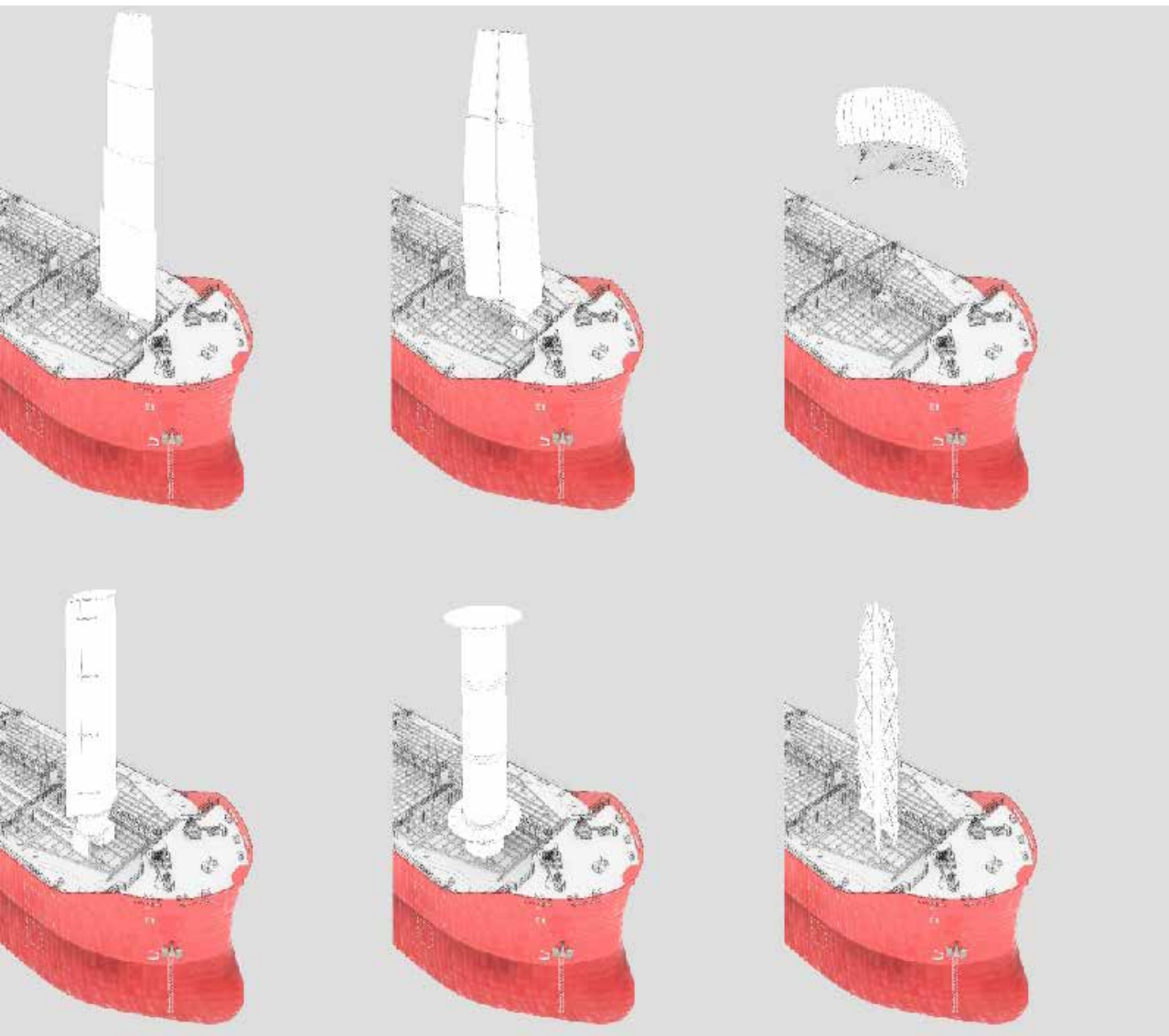

BUREAU VERITAS MARINE & OFFSHORE **RULE NOTE**

NR206 R04 July 2026

NR206 DT R04 July 2026 replaces the former edition March 2025.

The PDF electronic version of this document available on the Bureau Veritas Marine & Offshore website <https://marine-offshore.bureauveritas.com/> is the official version and shall prevail if there are any inconsistencies between the PDF version and any other available version.

These rules are provided within the scope of the Bureau Veritas Marine & Offshore General Conditions, enclosed at the end of Part A of NR467, Rules for the Classification of Steel Ships. The latest version of these General Conditions is available on the Bureau Veritas Marine & Offshore website.

BUREAU VERITAS MARINE & OFFSHORE

Tour Alto
4 place des Saisons
92400 Courbevoie - France
+33 (0)1 55 24 70 00

marine-offshore.bureauveritas.com/rules-guidelines

© 2026 BUREAU VERITAS - All rights reserved





Rule Note
NR206

WIND PROPULSION SYSTEMS

Section 1	General
Section 2	Documentation to be Submitted
Section 3	Materials, Equipment and Accessories
Section 4	Environmental Conditions and Design Loads
Section 5	Safety Rigging Parts Structure
Section 6	Operating Rigging Parts Structure
Section 7	Drive Systems
Section 8	Base Ship Requirements
Section 9	Sea Trials, Initial Inspection and Testing
Section 10	Wind Propulsion Prepared Ships
Appendix 1	Requirements for Survey of Materials and Equipment

Table of Content

Section 1	General	
1	General	6
1.1	Application	
1.2	Scope	
1.3	Classification notations	
1.4	Risk assessment	
1.5	Operating manual and maintenance instruction manual	
1.6	Applicable rules	
2	Definitions	9
2.1	Wind propulsion system types	
2.2	Elements constituting the wind propulsion system - Safety and operating rigging parts	
2.3	Ship hull areas	
Section 2	Documentation to be Submitted for Notations WINDPROPULSION	
1	General	13
1.1	Application	
Section 3	Materials, Equipment and Accessories	
1	Scope of application	16
1.1	Application	
1.2	General	
2	Construction materials	16
2.1	Steel	
2.2	Aluminium alloys	
2.3	Composite materials	
2.4	Other materials	
3	Manufacturing and testing	19
3.1	Welding and non-destructive testing	
3.2	Bolting	
3.3	Riveting for aluminium alloy elements	
3.4	Adhesive joint	
4	Equipment and accessories	21
4.1	Shrouds and stays (fore, back and running backstays)	
4.2	Mast slewing ring	
4.3	Winches	
4.4	Ropes	
4.5	Sheaves	
4.6	Wind propulsion system accessories	
4.7	Ship hull interface accessories	
5	Certification requirements	24
5.1	General	
Section 4	Environmental Conditions and Design Loads	
1	General	25
1.1	Design loads	
2	Environmental conditions	25
2.1	Wind	
2.2	Sea state	
2.3	Snow and ice	
3	Design load scenarios for strength assessment	26
3.1	General	

Table of Content

	4	Elementary design loads	27
	4.1	General	
	4.2	Wind loads	
	4.3	Static and inertial forces induced by ship motions	
	4.4	Ice	
	4.5	Pre-tensioning loads	
	4.6	Particular loads	
	5	Overall design loads	30
	5.1	Design Load combinations	
Section 5		Safety Rigging Parts Structure	
	1	General	33
	1.1	Application	
	2	Structure calculation approach	33
	2.1	Structural model	
	2.2	Documentation to be submitted	
	3	Stress analysis	34
	3.1	General	
	3.2	Stress analysis in shell elements made of steel and aluminium	
	3.3	Stress analysis in shell elements made of composite materials	
	3.4	Stress analysis in beam elements made of steel and aluminium	
	3.5	Stress analysis in beam elements made of composite materials	
	3.6	Stress analysis in rod elements	
	4	Scantling check	37
	4.1	General	
	4.2	Scantling check of items modeled as shell elements made of steel and aluminium	
	4.3	Scantling check of items modeled as shell elements made of composite materials	
	4.4	Scantling check of items modeled as beam elements made of steel and aluminium	
	4.5	Scantling check of items modeled as beam elements made of composite material	
	4.6	Scantling check of items modeled as rod elements	
	4.7	Scantling check of mast rotating systems	
	5	Scantling check for safety rigging parts connections	42
	5.1	Application	
	5.2	Welding and weld connections	
	5.3	Bolting connections	
	5.4	Riveting connections	
	5.5	Bonded connections	
	6	Scantling check for safety rigging parts accessories	44
	6.1	General	
	6.2	Scantling check	
	7	Scantling check for ship hull interface accessories	45
	7.1	General	
	8	Deflection	45
	8.1	Maximum horizontal deflection	
	9	Vibration	45
	9.1	General	
	10	Fatigue	45
	10.1	General	
Section 6		Operating Rigging Parts Structure	
	1	General	46
	1.1	Application	
	1.2	Documentation to be submitted	

Table of Content

	2	Calculation methods	46
	2.1	Application	
	3	Scantling check for operating rigging parts	46
	3.1	General	
	3.2	Scantling criteria for operating rigging parts	
	4	Scantling check for ship hull interface accessories	48
	4.1	General	
Section 7		Drive Systems	
	1	General	49
	1.1	Application	
	1.2	Applicable requirements	
	2	Main design principles	50
	2.1	General	
	2.2	Power sources	
	3	Electrical installations	51
	3.1	General	
	4	Machinery	51
	4.1	General	
	4.2	Hydraulic systems	
	4.3	Pneumatic equipment	
	5	Automation	53
	5.1	General	
	5.2	Remote control	
	5.3	Alarm system	
	5.4	Safety systems	
	5.5	Interconnection and relationship with the mechanical propulsion plant	
Section 8		Base Ship Requirements	
	1	Application	56
	1.1	General	
	2	General arrangement	56
	2.1	General	
	3	Stability	56
	3.1	General	
	3.2	Intact stability	
	3.3	Counter-heeling systems	
	4	Structural strength	60
	4.1	General	
	4.2	Design principles	
	4.3	Design loads	
	4.4	Local ship hull reinforcement	
	4.5	Strength check of the global hull girder	
	5	Hull outfitting	61
	5.1	Rudder	
	5.2	Keel and leeboard	
	5.3	Equipment for anchoring and mooring	
	6	Fire safety	62
	6.1	General	

Table of Content

	7	Electrical installation	62
	7.1	General	
	7.2	Lightning protection and earth protection	
Section 9		Sea Trials, Initial Inspection and Testing	
	1	General	64
	1.1	Application	
	2	Tests after fitting	64
	2.1	General	
	3	Sea trials	64
	3.1	General	
	3.2	Functional tests	
Section 10		Wind Propulsion Prepared Ships	
	1	General	66
	1.1	Application	
	1.2	Documentation to be submitted	
Appendix 1		Requirements for Survey of Materials and Equipment	
	1	Application	68
	1.1	General	
	1.2	Explanatory notes, symbols and abbreviations	
	1.3	Notice regarding columns 2 to 6 (product certification)	

Section 1 General

1 General

1.1 Application

1.1.1 The present Rule Note applies to wind propulsion systems fitted on board ships.

Wind propulsion systems mean technologies that directly transfer thrust forces created by the wind action on the system to the ship's structure.

The types of wind propulsion systems considered in this Rule Note are detailed in [2.1].

1.1.2 It is considered in this Rule Note that:

- apart from the wind propulsion system, the ship is equipped with an engine-driven propulsion system with sufficient power to maintain the manoeuvrability in adverse conditions when the wind propulsion system is out of operation
- the ship manoeuvrability is not impaired by the wind propulsion system in the various expected operational and environmental conditions.

The attention is drawn on any possible specific requirement regarding the manoeuvrability that may be defined by Flag Administration according to the service notation of the ship and its particulars.

1.1.3 This Rule Note also applies to the parts of ship affected by the installation of wind propulsion systems such as:

- general arrangement
- global and local hull structure
- stability
- rudder and steering gear
- equipment in chain and anchors.

It also applies to installations for essential services necessary for the ship to proceed at sea, be steered or manoeuvred, or undertake activities connected with its operation, and safety, such as:

- electrical installations
- machinery systems
- automation systems
- fire safety.

1.1.4 Sails

As a rule, surfaces on which wind will directly act (soft sails, rigid sails, inflatable sails or canopy for kite and rotating cylinder for rotor sail) are not covered within the scope of the present Rule Note.

However, these elements may be examined on a voluntary basis within the scope of an approval in principle process.

1.2 Scope

1.2.1 This Rule Note defines requirements for the:

- assignment of the notations **WINDPROPULSION** or **WINDPROPULSION -OPR** (see [1.3.2])
- assignment of the notation **WINDPROPULSION-PREPARED()** (see [1.3.3] and Sec 10)
- characteristics of structural materials and equipment used for the construction (see Sec 3)
- certification of materials and equipment (see Sec 3, [5])
- design load conditions (see Sec 4)
- safety rigging parts scantling (see Sec 5) and operating rigging parts scantling (see Sec 6)
- assessment of the electrical, hydraulic and automation drive systems (see Sec 7)
- assessment of the ship parts and systems affected by the propulsion system (see Sec 8)
- sea trials, initial inspection and testing (see Sec 9).

1.3 Classification notations

1.3.1 General

- a) Except for yacht and charter yacht, all ships fitted with a wind propulsion system are to be assigned the additional class notation **WINDPROPULSION** defined in [1.3.2].

The additional class notation may be complemented by the notation **-OPR** as defined in [1.3.2].

- b) Ships designed to accommodate the future installation of a wind propulsion system may be assigned the additional class notation **WINDPROPULSION-PREPARED()** defined in [1.3.3].

1.3.2 Ships fitted with a wind propulsion system

In accordance with NR467, Pt A, Ch 1, Sec 2, [6.16.1], ships equipped with a wind propulsion system as defined in [2.1], are assigned the additional class notation **WINDPROPULSION** and the safety rigging parts of the wind propulsion system are included in the scope of classification. The general requirements for the assignment of this notation are given in Sec 1 to Sec 5 and Sec 7 to Sec 10.

On a voluntary basis, the additional class notation **WINDPROPULSION** is completed by the notation **-OPR** when, in addition to the safety rigging parts, the operating rigging parts of the wind propulsion system are included in the scope of classification. The additional requirements for the assignment of the complementary notation **-OPR** are given in Sec 6.

Example:

WINDPROPULSION

WINDPROPULSION -OPR

The assignment of the additional class notation **WINDPROPULSION** is mandatory for ships assigned a service notation other than **yacht** or **charter yacht**.

Note 1: In accordance with NR500, Pt A, Ch 1, Sec 2, [2.3], ships assigned the service notation **yacht** or **charter yacht** and fitted with a sail propulsion are always completed by the additional service feature **sailing**. For these ships, the assignment of the additional class notation **WINDPROPULSION** and the complementary notation **-OPR** is voluntary.

The requirements for the maintenance of this notation are given in NR467, Part A, Ch 5, Sec 15.

1.3.3 Ships prepared for future installation of a wind propulsion system

In accordance with NR467, Pt A, Ch 1, Sec 2, [6.16.2], ships designed to accommodate the future installation of a wind propulsion system may be assigned the additional class notation **WINDPROPULSION-PREPARED()**.

This notation is to be completed between brackets by one or several of the following notations:

- **A** when the ship is arranged to accommodate the future installation of the wind propulsion system
- **S** when the stability of the ship is evaluated to take into account the future installation of the wind propulsion system
- **H** when the hull structure is designed to take into account the future installation of the wind propulsion system
- **O** when the hull outfitting for mooring and anchoring, rudder and steering gear are designed to take into account the future installation of the wind propulsion system
- **F** when the fire safety installations are designed to take into account the future installation of the wind propulsion system
- **E** when the electrical installations are designed to take into account the future installation of the wind propulsion system.

Example:

WINDPROPULSION-PREPARED (A, S, H)

WINDPROPULSION-PREPARED (O)

The requirements for the assignment of this notation are given in Sec 1 and Sec 10.

1.4 Risk assessment

1.4.1 Scope

A risk assessment is to be conducted to identify and address the risks arising from the use of wind propulsion systems affecting persons on board, the environment, the structural strength or the integrity of the ship. Consideration is to be given to the hazards associated with physical layout, operation and maintenance, following any reasonably foreseeable failure.

1.4.2 Methodology

The risks are to be analysed using acceptable and recognized risk analysis techniques. Loss of function, component damage, fire, stability and electric shock are to be considered, as a minimum. The analysis is to ensure that risks are eliminated wherever possible. Risks which cannot be eliminated are to be mitigated as necessary.

The assessment is to be carried out in accordance with acceptable and recognized techniques described in the current version of, for example, ISO 31010:2019 (Risk management - Risk assessment techniques), NORSOK Z-013 (Risk and emergency preparedness assessment standard) or CPR 12E. (Methods for determining and processing probabilities).

1.4.3 HAZID

An HAZID study is to be carried out, covering at least the following risks:

- the critical conditions that the system is capable to withstand for wind propulsion systems designed on the basis of unproven technology (new or without relevant experience history)
- the hazards and potential risks presented by mechanisms used for safeguarding the wind propulsion system in adverse environmental conditions (rotating, telescopic, foldable or tilting mechanisms)
- the risks arising from the use of the wind propulsion system affecting the integrity of the ship, such as:
 - damage the ship in such a way that flooding of water below the main deck or any progressive flooding occur
 - damage work areas or accommodation in such a way that people who stay in such areas under normal operating conditions are injured
 - disrupt the proper functioning of control stations and switchboard rooms for necessary power distribution and/or propulsion
 - damage life-saving equipment or associated launching arrangements
 - disrupt the proper functioning of fire-fighting equipment located outside the explosion-damaged space
 - affect other areas in the vessel in such a way that chain reactions involving, among others, cargo, gas and bunker oil may arise
 - prevent access to life-saving appliances or impede escape routes.

1.4.4 Failure Mode and Effect Analysis

A FMEA or a FMECA analysis is to be carried out for the drive systems of the wind propulsion system as deemed necessary by the HAZID study required in [1.4.3].

1.4.5 When required by the HAZID, the accidental conditions as defined in Sec 4, [3.1.2] are to be evaluated.

1.4.6 For modern rigs and traditional rigs of proven design as defined in [2.1.1], the risk assessment may be disregarded when deemed acceptable by the Society.

1.4.7 Risk analysis reports

A report defining the actions and mitigation measures resulting from the risk analysis is to be submitted to the Society.

1.5 Operating manual and maintenance instruction manual

1.5.1 Operating manual of the wind propulsion system

The operating manual of the wind propulsion system is to define the following information:

- a) The general operational instructions for safe operations of the wind propulsion system in:
 - seagoing conditions when the wind propulsion system is in operation
 - seagoing conditions when the wind propulsion system is in stand-by mode
 - accidental conditions evaluated by a risk analysis (if any).
- b) All permissible limits and operational restrictions for wind propulsion system operation, specifying the maximum apparent safe wind speed and direction (including gust effect) appropriate to the different configurations of the wind propulsion system to develop the thrust forces relative to the wind direction and the sea state, and the corresponding ship angle of heel
- c) Operational instructions release systems, if any.

The operating manual is to be kept available on board the ship.

In case the wind propulsion system is intended to be operated with the engine-driven propulsion system stopped, the following requirements have to be complied with:

- this operation mode is to be detailed in the operating manual including details and procedure for the starting of the engine-driven propulsion system in case of necessity
- this operating mode is to be taken into account in the risk assessment as defined in [1.4].

1.5.2 Maintenance plan

An installation, maintenance and inspection manual is to be submitted to the Society for information.

The following information is to be included in the maintenance plan:

- the critical details identified by the fatigue analysis according to Sec 5, [10] are to be listed
- in-service surveys are to be defined in the maintenance plan.

The repairs and criteria to replace equipment or accessories are defined at Society Surveyor' satisfaction.

The maintenance plan is to be kept on board the ship.

1.6 Applicable rules

1.6.1 Unless otherwise specified, the reference to other Rules of the Society are listed in Tab 1.

Table 1 : Reference to other Rules of the Society

Reference	Rule
NR467	Rules for the classification of steel ships
NR600	Hull structure and arrangement for the classification of cargo ships less than 65 m and non-cargo ships less than 90 m
NR500	Rules for the Classification and Certification of Yachts
NR216	Rules on materials and welding for the classification of marine units
NR266	Requirements for survey of materials and equipment for the classification of ships and offshore units
NR546	Hull in composite, plywood and high density polyethylene materials
NR561	Hull in aluminium alloys
NR615	Buckling assessment of plated structures

2 Definitions

2.1 Wind propulsion system types

2.1.1 The following types of wind propulsion systems are considered in the present Rule Note:

- **Modern rig:**
Rig with mast supporting mainsail and headsails, with or without spreaders and supported by transverse shrouds, forestay and backstays.
The sails trim to optimize the lift and thrust forces comprises a set of elements such as boom, mobile ropes, sheaves, clutch, winches.
The sails can be reefed and furled in unfavourable wind or extreme environmental conditions.
- **Traditional rig:**
Rig with mast supporting square sails and headsails supported by transverse and longitudinal shrouds.
The sails trim to optimize the lift and thrust forces comprises a set of elements such as boom, yards, mobile ropes, sheaves, clutch, winches.
The sails can be reefed and furled in unfavourable wind or extreme environmental conditions.
- **Free-standing rig:**
Self supporting mast directly embedded into the hull structure supporting main sail. As a rule, self supporting rigs have only mainsail.
The sail trim to optimize the lift and thrust forces comprises a set of elements such as boom or wishbone boom, mobile ropes, sheaves, clutch, winches... and/or a rotating system of the mast.
The sail can be reefed and furled in unfavourable wind or extreme environmental conditions.
- **Balestron rig:**
Self supporting mast directly embedded into the hull structure with integrated rigid boom extending fore and aft of the mast supporting the main sail and head sail. Mast forestay and/or backstay can be fixed to the balestron.
The sails trim to optimize the lift and thrust forces comprises a set of elements such as mobile ropes, sheaves, clutch, winch and a rotating system of the balestron rig.
The sails can be reefed and furled in unfavourable wind or extreme environmental conditions.
The balestron rig can be lowered by a tilting mechanism to drop the balestron rig on the ship deck in unfavourable wind or extreme external conditions.
- **Modern square-rig:**
Self supporting mast directly embedded into the hull structure with integrated curved yards fitted with yard shrouds supporting square sails.
The sails trim to optimize the lift and thrust forces comprises a mast rotating system.
The sails can be furled in the mast or the curved yards in unfavourable wind or extreme environmental conditions
- **Soft wing sails:**
Self supporting mast directly embedded into the hull structure with integrated boom and ribs supporting a soft sail. The soft wing sail may be equipped with a trailing edge coupled to the wing to change the camber of the profile.
The soft wing sail and flap adjustment to optimize the lift and thrust forces comprises a mast rotating system and a coupling system between the wing and the trailing edge.
The soft wing sail can be furled in unfavourable wind or in extreme environmental conditions.
The soft wing sail can be lowered by a tilting mechanism to drop the soft wing sail on the ship deck in unfavourable wind or extreme external conditions.

- Rigid wing sail:

Self supporting structure directly embedded into the hull structure. The rigid wing structure may consist of a mast or a load bearing-beam supporting the rigid wing sail or by the rigid wing sail structure itself when the rigid sail is of a self-supported structure type. The rigid wing sail may have a symmetrical profile or an asymmetrical profile and may be equipped with a trailing edge coupled to the wing to change the camber of the profile.

The rigid wing sail and flap adjustment to optimize the lift and thrust forces comprises a rotating system of the rigid wing sail and a coupling system between the wing sail and the trailing edge.

The rigid wing sail can be lowered by a telescopic retractable system, by a foldable system or by a tilting mechanism to drop the rigid wing sail on the ship deck in unfavourable wind or extreme external conditions.

- Kite sails:

Soft wing with an elliptical shape and geometry inflated with air, connected by towing ropes.

The kite is activated to perform a dynamic movement to maximize the traction force and is controlled through a control pod connected to the kite by a set of suspension ropes.

The kite can be retracted and docked back in unfavourable wind or extreme external conditions.

- Rotor sail:

Rotating cylinder powered by a motor, supported by a fixed self supporting tower directly embedded into the hull structure, generating lift force induced by a differential pressure between its opposite sides when it is exposed to an air flow (Magnus effect).

The intensity of the lift force is conditioned by the rotation speed of the rotating cylinder.

The rotor cylinder can be stopped or the rotor sail can be lowered by a tilting mechanism to drop the rotor sail on the ship deck in unfavourable wind or extreme external conditions.

- Suction wing sails:

Orientable rigid wing sail, with or without trailing edge coupled to the wing sail, with an internal mechanical air suction mechanism system to use boundary layer suction effect.

The suction wing sail adjustment to optimize the lift and thrust forces comprises a mast rotating system, a coupling system between the wing and the trailing edge and a speed air-regulation system.

The ventilator can be stopped and the trailing edge located in a centered position or the suction wing sail can be lowered by a tilting mechanism to drop the suction wing sail on the ship deck in unfavourable wind or extreme external conditions.

2.1.2 Other wind propulsion system are to be considered on a case by case basis by the Society.

2.2 Elements constituting the wind propulsion system - Safety and operating rigging parts

2.2.1 General

a) The terms “safety rigging parts” and “operating rigging parts” are to be regarded as generic terms in this Rule Note. They are used to refer to the different elements of the propulsion system to be considered within the scope of the notations **WINDPROPULSION** and **WINDPROPULSION -OPR** according to [1.3.2].

Safety and operating rigging parts are defined in [2.2.2] and [2.2.3] respectively.

b) List of main elements:

An inventory list of the main elements of the wind propulsion system is to be submitted to the Society for information in order to agree how the listed items are to be considered and categorized as safety or operating rigging parts.

Safety and operating rigging parts are categorized in Tab 2 for information according to the type of wind propulsion system.

2.2.2 Safety rigging parts of the wind propulsion system

The safety rigging parts mean:

- all the structural elements and accessories essential to the structural integrity of the wind propulsion system, preventing partial or whole collapse in all the design load scenarii defined in Sec 4, [3.1.1]. As a rule, it includes all the structural elements supporting the sails defined in [1.1.4].
- all the drive systems playing an essential part in the safety and structural integrity of the wind propulsion system in the design load scenarii SB-SEA and SB-HAR defined in Sec 4, [3.1.1], including the safety systems as defined in Sec 7.

The components and constituents of a safety rigging part of a wind propulsion system are defined in Tab 2 according to the type of wind propulsion system considered.

2.2.3 Operating rigging parts of the wind propulsion system

The operating rigging parts mean all the elements, accessories and drive systems used for the sails trim and adjustments of the wind propulsion system in the design load scenario OP-SEA defined in Sec 4, [3.1.1]. They are considered as non-essential to the structural integrity of the wind propulsion system.

The components and constituents of a operating rigging part of a wind propulsion system are defined in Tab 2 according to the type of wind propulsion system considered.

2.2.4 Drive unit

The drive unit includes the machinery and electrical equipments used to operate, control and monitor the wind propulsion system.

2.2.5 Automatic release system

Release system refers to the mechanism and associated control arrangements that are used to automatically release the loads on the wind propulsion system in a controlled manner.

2.3 Ship hull areas

2.3.1 The ship hull areas are the hull areas supporting the reaction forces and moments induced by the safety and operating rigging parts in way of:

- mast, load bearing-beam supporting wing sail, self supporting tower, winch and telescopic mast for kite
- rotating systems
- tilting systems
- pad eyes, chain plates
- sheet track rails, sheaves support, clutch
- winches, hydraulic cylinders.

Table 2 : Safety and operating rigging parts

Wind propulsion system	Safety rigging parts	Operating rigging parts
Modern rig	<ul style="list-style-type: none"> • Masts, shrouds, fore and back stays, running backstays, cable turnbuckles, spreaders, chain plates • Drive systems (3) 	<ul style="list-style-type: none"> • Booms, sail sheets and halyards, winches, clutch, sheaves • Drive systems as defined (3)
Traditional rig	<ul style="list-style-type: none"> • Masts, shrouds, fore and back stays, running backstays, cable turnbuckles, chain plates • Drive systems (3) 	<ul style="list-style-type: none"> • Yards, sail sheets, winches, clutch, sheaves • Drive systems as defined (3)
Free standing rig	<ul style="list-style-type: none"> • Mast • Drive systems (3) 	<ul style="list-style-type: none"> • Boom or wishbone boom, sail sheets and halyards, winches, clutch, sheaves, mast rotating system if any (1) • Drive systems (3)
Balestron rig	<ul style="list-style-type: none"> • Mast and integrated long boom, fore stay, backstays and running backstays when provided • Tilting mechanisms used for safeguarding the wind propulsion system in adverse environmental conditions if any • Drive systems (3) 	<ul style="list-style-type: none"> • Sail sheets and halyards, winches, clutch, sheaves, mast rotating system (1) • Drive system (3)
Modern square-rig	<ul style="list-style-type: none"> • Mast and integrated curved yards, yard shrouds • Drive systems (3) 	<ul style="list-style-type: none"> • Mast rotating system (1) • Drive systems as defined in Sec 7, [1.1.2]
Soft wing sail	<ul style="list-style-type: none"> • Mast and integrated long boom, trailing and leading edges coupled to the mast if any • Tilting mechanisms used for safeguarding the wind propulsion system in adverse environmental conditions if any • Drive systems (3) 	<ul style="list-style-type: none"> • Mast rotating system (flap rotation system if any) (1) • Drive systems (3)
Rigid wing sail	<ul style="list-style-type: none"> • Rigid wing structure and its coupled trailing and leading edges, if any (mast or load bearing-beam supporting the wing sail, or rigid wing sail structure if the rigid wing is of a self-supported structure type) • Telescopic, foldable or tilting mechanisms used for safeguarding the wind propulsion system in adverse environmental conditions if any • Drive systems (3) 	<ul style="list-style-type: none"> • Mast rotating system (flap rotation system if any) (1) • Telescopic or foldable systems used in normal environmental conditions • Drive systems (3)
<p>(1) When the mast rotating system (slewing ring) is part of a set of an automatic release system to avoid wind overload on the wind propulsion system considered for the scantling of the safety rigging parts, or used for safeguarding the wind propulsion system in adverse environmental conditions, the slewing ring is to be considered as safety rigging parts.</p> <p>(2) When the kite control pod is part of a set of an automatic release system to avoid wind overload on the wind propulsion system considered, it is to be considered as safety rigging parts</p> <p>(3) As defined in Sec 7, [1.1.2].</p>		

Wind propulsion system	Safety rigging parts	Operating rigging parts
Kite	<ul style="list-style-type: none"> • Mast used during deploying operations, kite suspension ropes, sheaves, winch • Drive systems (3) 	<ul style="list-style-type: none"> • Kite control pod, control lines with sheaves and dedicated winches (2) • Drive systems (3)
Rotor sail	<ul style="list-style-type: none"> • Self supporting tower, tilting mechanisms used for safeguarding the wind propulsion system in adverse environmental conditions if any • Drive systems (3) 	<ul style="list-style-type: none"> • Drive systems (3)
Suction wing sail	<ul style="list-style-type: none"> • Wing mast, tilting mechanisms used for safeguarding the wind propulsion system in adverse environmental conditions if any • Drive systems (3) 	<ul style="list-style-type: none"> • Mast rotating system (flap rotation system if any) (1), Air suction system • Drive systems as defined (3)
<p>(1) When the mast rotating system (slewing ring) is part of a set of an automatic release system to avoid wind overload on the wind propulsion system considered for the scantling of the safety rigging parts, or used for safeguarding the wind propulsion system in adverse environmental conditions, the slewing ring is to be considered as safety rigging parts.</p> <p>(2) When the kite control pod is part of a set of an automatic release system to avoid wind overload on the wind propulsion system considered, it is to be considered as safety rigging parts</p> <p>(3) As defined in Sec 7, [1.1.2].</p>		

Section 2 Documentation to be Submitted for Notations WINDPROPULSION

1 General

1.1 Application

1.1.1 The present Section defines the documentation to be submitted for the assignment of the additional class notation **WINDPROPULSION** or **WINDPROPULSION -OPR** to ships fitted with a wind propulsion system.

1.1.2 Documentation to be submitted for the wind propulsion system

The general documentation to be submitted is listed in Tab 1 for the wind propulsion system and in Tab 3 for the drive system.

The additional documentation to be submitted for the complementary notation **-OPR** is listed in Tab 2.

Note 1: Some documentation related to wind propulsion systems may be submitted by ship designer when the wind propulsion system is integrated to a ship.

1.1.3 Documentation to be submitted for the base ship

The documentation to be submitted for the base ship on which the wind propulsion system is installed is listed in Tab 4.

Note 1: Some documentation related to wind propulsion systems may be submitted by ship designer when the wind propulsion system is integrated to a ship.

Table 1 : General documentation to be submitted for the wind propulsion system

No.	A/I (1)	Documentation	Particulars
1	I	Functional description of the wind propulsion system	
2	I	Nomenclature of the wind propulsion system components	Covered within the scope of classification with regard to the assigned notation
3	I	Operating manual	Including the operational design conditions with meteorological limit conditions (wind and sea state)
4	I	Weight distribution report	
5	A	All drawings necessary to define the safety rigging parts	Specifying the materials and the connections between the different elements of the safety rigging parts (2)
6	I	Scantling justification report	<ul style="list-style-type: none"> • according to Sec 5, [2.2] • specifying for the different operating conditions (3): <ul style="list-style-type: none"> - the scantling design loads (wind speed and sea state conditions) considered and the safety margins against the operational manual defined in Sec 1, [1.5.1] if any - the detailed description of structural model including all model assumptions, assigned material properties and boundary conditions - the wind loads distribution on the model - the summaries and plots of deflections, forces reactions and stresses - the tabulated results showing the scantling design criteria considered - the computer calculations, reference
7	A	Drawings necessary to define the release systems to avoid wind overload	When taken into account for the structure assessment of the wind propulsion system
8	I	Shrouds and stays pre-tensioning values specifying the pre-tensioning control process at construction and in operation	where applicable

(1) A: for approval; I: for information

(2) Structural categories as defined in Sec 3, [3.1.2] are to be indicated in the appropriate drawings.

(3) Justifications may be based on experimental results, recorded on similar structures and possibly corrected to take into account minor variations of some parameters, effects of which have been suitably evaluated.

In that case, the tested structures, the test conditions, methods and results are to be defined, and variations in the parameters and their effects on the structure are to be justified

No.	A/I (1)	Documentation	Particulars
9	A	Systems used to put the wind propulsion system in "safe mode" in adverse environmental conditions	
10	A	Chain plates, pad eyes, etc., supporting the forces reactions induced by the safety rigging parts	
11	A	Connections of the slewing ring with mast	As applicable
12	I	Installation, maintenance and inspection manual	Including pre-tensioning values, as applicable
13	I	Aerodynamic test results in wind-tunnel	when relevant
14	A	Plan for non-destructive examinations	
15	I	Vibration analysis	

- (1) A: for approval; I: for information
 (2) Structural categories as defined in Sec 3, [3.1.2] are to be indicated in the appropriate drawings.
 (3) Justifications may be based on experimental results, recorded on similar structures and possibly corrected to take into account minor variations of some parameters, effects of which have been suitably evaluated.
 In that case, the tested structures, the test conditions, methods and results are to be defined, and variations in the parameters and their effects on the structure are to be justified

Table 2 : Additional documentation to be submitted for wind propulsion system - Ships assigned the complementary notation -OPR

No.	A/I (1)	Documentation	Particulars
1	A	All the drawings necessary to define the operating rigging parts	Specifying the materials and the mechanical characteristics of the different elements of the operating rigging parts (2)
2	A	Halyard and sheet ropes characteristics	According to Sec 6, [1.2]
3	A	Winch, clutch, sheet track rails, sheave supports characteristics... supporting the forces reactions induced by the operating rigging parts	according to Sec 6, [1.2]

- (1) A: for approval; I: for information
 (2) Justifications may be based on experimental results, recorded on similar structures and possibly corrected to take into account minor variations of some parameters, effects of which have been suitably evaluated.
 In that case, the tested structures, the test conditions, methods and results are to be defined, and variations in the parameters and their effects on the structure are to be justified

Table 3 : Documentation to be submitted for drive system

No.	A/I (1)	Documentation	Particulars
1	I	General specification for the automation of the wind propulsion system	Including: <ul style="list-style-type: none"> • specification of the safety devices • specification of the mechanical propulsion plant.
2	I	General operating principles of the wind propulsion system	Including: <ul style="list-style-type: none"> • description of modes of control (at open sea, in manoeuvre) • description of possible combinations of the various means of propulsion • description of propeller - sail coordination • modes of propulsion power sharing within the wind propulsion system and the main engine.
3	A	Detailed specification of the essential service systems	
4	A	List of components used in the automation circuits, and references	Manufacturer, type, etc.
5	I	Instruction manuals	
6	A	Diagram of the supply, monitoring and control systems of the wind propulsion system	

- (1) A: for approval; I: for information
 (2) As mentioned in NR467, Pt C, Ch 3, Sec 3, Tab 2
Note 1: Some documentation may be provided either by the wind propulsion system designer or by the ship designer, depending on the systems.

No.	A/I (1)	Documentation	Particulars
7	A	All the drawings necessary to define the general arrangement of the electrical and hydraulic installations	When applicable
8	I	List of computerized systems	As mentioned in NR467, Pt C, Ch 3, Sec 3, [1.6.1]
9	I	Software Registry	<ul style="list-style-type: none"> As mentioned in NR467, Pt C, Ch 3, Sec 3, [8.1.1] Including specification of the data processing hardware and description of the application software
10	I	Safe type certificate	<ul style="list-style-type: none"> Or equivalent according to NR467, Pt C, Ch 2, Sec 3, [10.3] when relevant
11	I	Test program and procedures for control, alarm and safety systems	
12	A	Arrangement of the control stations	Including a general diagram showing the monitoring and/or control positions for the various installations, with an indication of the means of access and the means of communication between the positions as well as with the engineers
13	A	List of monitored parameters for alarm/monitoring and safety systems	
14	A	Sensor list and data sheets	With justification of their qualification for the sea-going environmental conditions
15	I	Explanatory note on sensor location and duplication	Where necessary
16	A	Note on the analog sensor signal processing	
17	A	Alarm list and alarm system specification	
18	A	Diagram of the engineers' alarm system	
19	A/I (2)	Documentation and test attendance for computer based systems	

(1) A: for approval; I: for information
(2) As mentioned in NR467, Pt C, Ch 3, Sec 3, Tab 2
Note 1: Some documentation may be provided either by the wind propulsion system designer or by the ship designer, depending on the systems.

Table 4 : Documentation to be submitted for the base ship on which the wind propulsion system is installed

No.	A/I (1)	Documentation	
1	I	General arrangement of the ship showing the wind propulsion system	
2	I	Risk assessment report	According to Sec 1, [1.4]
3	I	Operating manual	Including the operational design conditions and environmental limiting conditions (wind and sea state)
4	A	Local hull structure reinforcements in way of ship hull areas	As defined in Sec 1, [2.3] Specifying the force reactions induced by the safety and operating rigging parts (winch, clutch, sheet track rails, sheave supports)
5	A	Connections of the slewing ring with the hull supporting structure in case of mast rotating systems	
6	I	Global hull girder calculation	According to Sec 8, [4.5]
7	A	Ship hydraulic and electrical installations intended to power the operating rigging system, as applicable	
8	A	Stability booklet	
9	A	Equipment number calculation	
10	I	Electrical load balance	
11	I	Fatigue analysis of the local hull structure	According to Sec 8, [4.4.2]
12	A	Fire protection, fire detection and fire fighting system	If any

(1) A: for approval; I: for information

Section 3 Materials, Equipment and Accessories

1 Scope of application

1.1 Application

1.1.1 The following materials, equipment and manufacturing processes are to comply with the requirements of this Section:

- materials and manufacturing process used for the mast or self supporting structure or tower, boom and long boom, spreader, yards, rotating devices
- shrouds and stays used for the safety rigging parts (steel wire rope, steel rod, synthetic fibres) and their terminals and accessories (turnbuckle, chain plate)
- safety rigging parts accessories and accessories between safety rigging parts and ship hull structure
- ropes and accessories for the operating rigging parts and their connection with ship hull structure (sail sheets and halyards, sheaves, padeyes, winches).

1.1.2 Drive systems

The drive systems are to comply with Sec 7.

1.2 General

1.2.1 Corrosion

- Structures and components constituting the wind propulsion system are to be protected against corrosion damage in marine environment, using suitable materials, combined with additional protective measure such as coating, if necessary.
- It is the responsibility of the wind propulsion system builder to define an overall plan for the corrosion protection specifying the characteristics of coating systems adapted to the nature of material, the surface preparation, the location of the component to be protected.

1.2.2 Navigation in cold environment

For ships assigned one of the additional class notations **COLD DI**, **COLD BASIC (H t_{DH}, E t_{DE})** and **COLD (H t_{DH}, E t_{DE})**, the wind propulsion systems is to comply with requirements of NR467, Pt F, Ch 8, Sec 4.

For the purpose of issuing a Polar Ship Certificate in accordance with the Polar Code, Polar Service Temperature (PST) of the ship is to be defined as per NR527, Sec 4, [1.2.3].

In the polar regions, the statistical mean over observation period is to be determined for a period of, at least, 10 years.

2 Construction materials

2.1 Steel

2.1.1 General

Steel materials are to be in compliance with the applicable requirements of NR216.

2.1.2 Stainless steels are considered by the Society on a case-by-case basis.

2.1.3 Structural steel grades

As a rule, the steel grades to be used for structural elements are defined in Tab 1 according to the plate thickness.

Table 1 : Steel grade for plates

Plate thickness t, in mm	Hull steel grade
$t \leq 20$	A or AH
$20 < t \leq 25$	B or AH
$25 < t \leq 40$	D or DH
$40 < t$	E or EH

2.1.4 Mechanical properties

a) Tab 2 gives the mechanical characteristics of steels to be generally used in the construction.

Note 1: For carbon steel materials, Young’s modulus is taken equal to 206000 N/mm² and Poisson’s ratio is taken equal to 0,3.

b) Higher strength steels other than those indicated in Tab 2 are considered by the Society on a case-by-case basis. In such a case, a detailed technical specification stating the manufacturing process, mechanical and chemical characteristics, ability for welding and forming, and the possible heat-treatments is to be submitted to the Society.

c) Where normal tensile loads induce out-of-plane stress greater than 0,5 R_{eH} in steel plates, the following measures are to be taken in order to prevent the risk of lamellar tearing;

- for plates with t < 15 mm, ultrasonic testing is to be carried out as detailed hereafter
- for plates with t ≥ 15 mm, Z-quality steel is to be used or ultrasonic testing is to be carried out as detailed hereafter.

The ultrasonic testing is to be carried out, before and after welding, over the full length of the weld joint to cover a band of 50mm width or “t”, whichever is the greater, on each side of the weld axis, in accordance with NR216, Ch 3, Sec 12.

Table 2 : Mechanical properties of steels

Steel grades t ≤ 100 mm	Minimum yield stress R _{eH} , in N/mm ²	Ultimate minimum tensile strength R _m , in N/mm ²
A-B-D-E	235	400 - 520
AH32-DH32 EH32-FH32	315	440 - 570
AH36-DH36 EH36-FH36 EH36CAS-FH36CAS	355	490 - 630
AH40-DH40 EH40- FH40 EH40CAS-FH40CAS	390	510 - 660
EH47 EH47CAS	460	570 - 720
Note 1: See NR216, Ch 3, Sec 2		

2.1.5 Design yield stress for scantling structure check

The design yield stress R_y, in N/mm² to be considered for the scantling structure check is to be taken equal to:

$$R_y = \min\left(R_{eH}, \frac{R_m}{1,2}\right)$$

where:

R_{eH}, R_m : Yield stress and ultimate tensile stress as defined in [2.1.4].

2.1.6 Steel for forgings and steel castings

Mechanical and chemical properties of steel forgings and steel castings used for structural members are to comply with the applicable requirements of NR216.

Steel forgings and steel castings intended for welded construction are to be in accordance with the applicable requirements of NR216.

2.1.7 Low temperature air

For ships intended to operate in areas with low air temperatures (–10°C or below), e.g. regular service during winter seasons to Arctic or Antarctic waters (known as the Polar Regions), the materials in exposed structures are to be selected based on the design temperature, to be taken as defined in NR467, Pt B, Ch 4, Sec 1.

For this purpose, the grade of steel to be used for wind propulsion system elements is to be considered as Class II (See NR467, Pt B, Ch 4, Sec 1, [2.5]).

2.2 Aluminium alloys

2.2.1 General

Aluminium alloys are to comply with the applicable requirements of NR216.

2.2.2 Aluminium alloys

a) As a rule, the aluminium alloys used for the construction are as follows:

- For rolled or extruded products:
 - series 5000: aluminium-magnesium alloy
 - series 6000: aluminium-magnesium-silicon alloy.

- For cast products:
 - aluminium-magnesium alloy
 - aluminium-silicon alloy
 - aluminium-magnesium-silicon alloy.

b) Influence of welding on mechanical characteristics:

Welding heat input lowers locally the mechanical characteristics $R_{p0,2}$ and R_m of aluminium alloys hardened by work hardening (series 5000 other than condition O) or by heat treatment (series 6000).

Consequently, where necessary, a drop in the mechanical characteristics of welded structures, with respect to those of the parent material, is to be considered for the structural calculation.

Note 1: As a general rule the heat affected zone (HAZ) is to be taken extending over 25 mm on each side of the weld axis.

c) Aluminium alloys of series 5000 (rolled or extruded):

Aluminium alloys of series 5000 in condition O (annealed) are not subject to a drop in mechanical strength in the welded areas.

Aluminium alloys of series 5000 other than condition O are subject to a drop in mechanical strength in the welded areas. The mechanical characteristics to be considered are normally those of condition O.

d) Aluminium alloys of series 6000:

Aluminium alloys of series 6000 are subject to a drop in mechanical strength in the vicinity of the welded areas.

The mechanical characteristics to be considered in this HAZ are normally indicated by the supplier.

When no information is provided by the supplier, the values given in Tab 4 may be used.

e) Unless otherwise agreed, the Young’s modulus for aluminium alloys is equal to 70000 N/mm² and the Poisson’s ratio equal to 0,33.

2.2.3 Design yield stress for scantling structure check

The design yield stress R_y , in N/mm² to be considered for the scantling structure check is to be taken equal to the minimum specified yield stress of the parent metal in welded condition $R'_{p0,2}$, in N/mm², but not to be taken greater than 70% of the minimum specified tensile strength of the parent metal in welded condition R'_m , in N/mm²

where:

$$R'_{p0,2} = \eta_1 R_{p0,2}$$

$$R'_m = \eta_2 R_m$$

$R_{p0,2}$: Minimum specified yield stress, in N/mm², of the parent metal in delivery condition

R_m : Minimum specified tensile stress, in N/mm², of the parent metal in delivery condition.

η_1 and η_2 are given in Tab 3.

2.2.4 Low temperature air

For ships intended to operate in areas with low air temperatures (–10°C or below), the aluminium alloys to be employed are to be agreed by the Society.

Table 3 : Aluminium alloys table for welded construction

Aluminium alloy	η_1	η_2
Alloys without work-hardening treatment (series 5000 in annealed condition O or annealed flattened condition H111)	1	1
Alloys hardened by work hardening (series 5000 other than condition O or H111)	$R'_{p0,2}/R_{p0,2}$	R'_m / R_m
Alloys hardened by heat treatment (series 6000) (1)	$R'_{p0,2}/R_{p0,2}$	0,6
(1) When no information is available, coefficient η_1 is to be taken equal to the metallurgical efficiency coefficient β defined in Tab 4.		
Note 1:		
$R'_{p0,2}$: Minimum specified yield stress, in N/mm ² , of material in condition O		
R'_m : Minimum specified tensile stress, in N/mm ² , of material in condition O		

Table 4 : Metallurgical efficiency coefficient β

Aluminium alloy	Temper condition	Gross thickness, in mm	β
6005 A (Open sections)	T5 or T6	$t \leq 6$	0,45
		$t > 6$	0,40
6005 A (Closed sections)	T5 or T6	All	0,50
6061 (Sections)	T6	All	0,53
6082 (Sections)	T6	All	0,45

2.3 Composite materials

2.3.1 General

The characteristics of the composite materials are to comply with the applicable requirements of NR546 "Hull in Composite Materials" in particular for the:

- raw materials analysis
- individual layers and laminate analysis.

Raw materials and laminates are to be tested in compliance with the applicable requirements of NR546.

2.3.2 Mechanical properties

The design review of the scantling of elements built in composite materials consists in checking the actual safety coefficients, equal to the ratio between the theoretical breaking stresses of the elementary layers of the laminate and the actual applied local stresses.

The values of the theoretical breaking stresses are defined in the NR546, Sec 5, [5].

Breaking stresses directly deduced from mechanical tests may be taken over from the theoretical breaking stresses defined in NR546 if mechanical test results are noticeably different from expected values.

2.3.3 Air temperature

a) General:

Attention is to be paid to the value of the T_g (glass transition temperature) of the composite material, primarily dependant on resin type and post-cure process.

As a rule, the value of T_g is to be at least greater than the air temperature provided in service increased by 15°.

b) Low temperature air:

For ships intended to operate in areas with low air temperatures (-10°C or below), the composite materials to be employed are to be agreed by the Society.

2.3.4 UV protection

UV protection by gel coat or painting and protection in way of fretting wear are to be provided.

2.4 Other materials

2.4.1 Other materials may be considered by the Society on a case-by-case basis.

3 Manufacturing and testing

3.1 Welding and non-destructive testing

3.1.1 General

The general requirements for fabrication by welding (welding consumables and procedures) for steel and aluminium alloys are defined in NR216.

Additional requirements for scantling, preparation, execution and inspection of steel welded connections are defined in NR467, Pt B, Ch 13, Sec 1.

Additional requirements for scantling, preparation, execution and inspection of aluminium alloys welded connections are defined in NR561, Sec 3.

3.1.2 Structural category

As a rule, the plan for non-destructive examination of weld joints is to be submitted to the Society based on the following structural element categories:

- Second category:
Second category elements are structural elements of minor importance, the failure of which might induce only localised effects.
- First category:
First category elements are structural elements essential to the overall structural integrity of the unit.
- Special category:
Special category elements are parts of first category elements located in way or at the vicinity of critical load transmission areas and of stress concentration locations.

Structural categories are to be indicated on the drawings submitted to the Society.

3.1.3 Plan for non-destructive examinations

A plan specifying the areas to be examined and the extent of testing and the quality levels, with reference to the NDT procedures to be used, is to be submitted to the Society for approval.

The lengths of weld and the location of welds to test are to be defined on a case by case basis taking into account the following criteria:

- structural category defined in [3.1.2]
- welds in high stressed areas
- fatigue sensitive areas
- other important structural elements
- welds which are inaccessible or very difficult to inspect in service
- suspected problem areas.

3.2 Bolting

3.2.1 When standardized bolts are used for connections of safety rigging elements, the screws and nuts are to be of the steel quality grades defined in Tab 5 in accordance with the requirements of the ISO 898. For the screws, this table specifies also the tensile strength R and the minimum yield stress R_e which are to be taken into account in strength calculations.

The threading of screws is to be formed by rolling.

3.2.2 The designation symbol of the steel quality grade mark is to be indicated on each screw and nut used.

3.2.3 For assemblies with pre-stressed high strength bolts, the quality grade marks of the screws are to be 8.8 or 10.9 and the quality grade marks of the nuts 8 or 10 respectively. The quality of the washers are to be appropriate to the quality grade marks of the screws and nuts.

Screw threading is to be obtained by rolling, exclusive of any other process.

Note 1: Applications for use of bolts with screws of 12.9 quality grade mark will be subject to special consideration.

Table 5 : Steel quality grade marks for screws and nuts

Quality grade marks for screws	6.8	8.8	10.9	12.9
Tensile strength of screws, in N/mm ²	600	800	1 000	1 200
Yield stress (minimum) of the screws, in N/mm ²	480	640	940	1 080
Quality grade marks for nuts	6	8	10	12
Note 1: Alternatively, other steel quality grades defined by national standards may be accepted.				

3.3 Riveting for aluminium alloy elements**3.3.1 General**

The conditions of riveting of aluminium alloy elements are defined in NR561, Sec3.

The aluminium alloy rivets characteristics are to be as defined in NR216, Ch 9, Sec 3.

As a rule, the rivet joints scantling are examined on a case by case basis by direct calculation approach.

3.4 Adhesive joint**3.4.1 General**

The following technical specifications of the adhesive joint are to be specified by the supplier:

- adhesive system type and trade mark
- density, Young modulus, shear modulus, Poisson coefficient
- breaking strength and elongation at break in tensile and shear.

In addition, the following parameters are to be specified:

- surface preparation (abrasion, cleaning...) and surface treatment of the components to be bonded
- geometry and thickness of the bonded joint
- service temperature range
- service humidity range
- curing process of the bonded joint.

3.4.2 Design shear stress for adhesive joint joint scantling check

As a rule, the value of the shear breaking stress to be considered is to be taken equal to the minimum value of the:

- initial shear yield stress, in N/mm², of the bonding resin specified by the supplier, corresponding to the initial yield stress on a substrate equivalent to the examined components, or
- theoretical breaking stress value τ_{IL} , in N/mm², of the first layer of the components bonded together.

The shear breaking stress may be determined on the basis of shear stress-strain curve as the intersection of a line tangent to the linear elastic region and a line tangent to the non linear plastic region of the curve (see Fig 1). This curve is to be defined taking into account the maximum air temperature provided in service.

Other values of shear breaking stress deduced from mechanical tests representative of the gluing joint parameters may be considered by the Society where deemed necessary.

Figure 1 : Initial yield stress

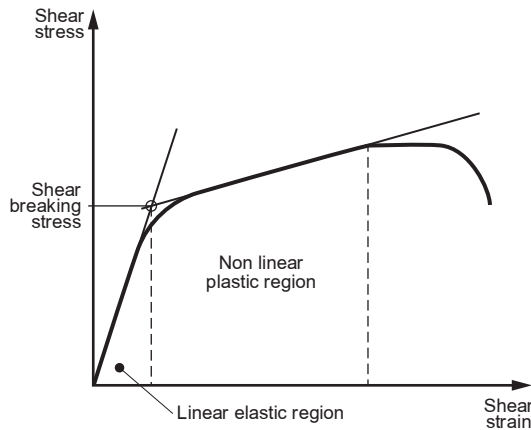

3.4.3 Mechanical tests

a) General:

Mechanical tests are to be carried out for structural gluing joints. The type of tests and the test temperature ranges are to be defined at the satisfaction of the Society.

The type and preparation of adherent, the application of adhesive and the curing process of test samples are to be representative of the construction process.

The characteristics of the sample tests (geometry and thickness of the gluing joint, stiffness of the adherends) are to be as much as possible representative of the actual joint to be characterized.

b) Documents to be submitted:

A test program specifying the considered mechanical tests and the number of specimen to be tested is to be submitted to the Society.

A technical report including the forces/displacements curves is to be submitted to the Society.

4 Equipment and accessories

4.1 Shrouds and stays (fore, back and running backstays)

4.1.1 The following material specifications of shrouds and stays and their accessories (end fittings, turnbuckle, stay tensioner...) are to be submitted for information:

- steel wire cable: composition and type of strand, grade, diameter
- rod cable: material, diameter
- carbon cable: type of fibre and resin
- synthetic cable: type of fibre.

4.1.2 For all type of cables, the following information are to be submitted:

- maximum breaking and safe working loads,
- load strain curve of shroud and stay
- expected service life and maintenance process and survey.
- arrangement details of end fittings, turnbuckle, stay tensioner...
- humidity, corrosion, UV and chafe protections.

Impact protection are to be provided, particularly for fibre cables, when objects hitting wind propulsion system elements may occur.

4.1.3 Steel wire cables and fibre cables are to be in accordance with the requirements of NR216 or other recognized standard accepted by the Society.

A programme of tests and examination, based on the requirements of the applicable standard is to be submitted to the Society for approval.

4.1.4 Control of pre-tensioning

Arrangements to control in service the pre-tensioning applied to the safety rigging parts by turnbuckles, stay tensioners or equivalent systems are to be justified by the Designer.

4.2 Mast slewing ring

4.2.1 A calculation note and an attestation from the slewing ring manufacturer, fixing the maximum permissible values for overturning moment and vertical force in the working conditions is to be submitted according to Sec 6, [3.2.4].

A BV product certificate is required with invitation of the Surveyor of the Society to attend the tests in addition to the manufacturer's document.

Raw materials data sheets of the main elements of the slewing ring including data such as chemical composition and mechanical properties are to be submitted.

4.2.2 Slewing ring and its associated drive systems are to be considered as:

- operating rigging parts when used for the sails trim and adjustments of the wind propulsion system in design load scenario OP-SEA defined in Sec 4, [3.1.1]
- safety rigging parts when playing an essential part in the safety and structural integrity of the wind propulsion system in design load scenarii SB-SEA and SB-HAR defined in Sec 4, [3.1.1].

4.3 Winches

4.3.1 Winches and testing procedures are to be in accordance with the requirements of the Rules of the Society, such as NR526, Ch 2, Sec 6 or other recognized standards.

Note 1: NR526 Rules for the certification of lifting appliances onboard ships and offshore units.

4.3.2 Construction drawings of winches are not required when standardized production is concerned, provided references of use in service are supplied to the Society satisfaction.

When prototype is concerned, a technical file is to be submitted for information. This file is to include a detailed technical specification, an operating manual, a general drawing, the constructional drawings of the main items and complete calculations of the Manufacturer. A test programme according to [4.3.1] is to be submitted for approval.

4.3.3 The following main winch capacity are to be submitted:

- rated line pull (RP): Line tension, in kN, that the winch can haul at a specified layer and in a safe manner
- brake capacity: Minimum rated holding force, in kN, of the static brake system at the reeled layer for which the RP is specified
- required nominal force: Line pull force that the winch can haul at the outer winding layer, in normal service conditions, when the drum rotates at its maximum service speed (nominal recovery speed) in order to satisfy the intended performance
- pulling capacity limiter: Capacity value of the device that prevents the winch to pull-in a load in excess of its rated or allowed overload capacity.

4.4 Ropes

4.4.1 The following material specifications of ropes are to be submitted for information:

- type of material and composition
- rope construction (braided or unidirectional fiber for core, type of cover)
- minimum breaking and safe working loads, elongation
- expected service life.

4.4.2 Ropes are to be in accordance with the requirements of NR216 or other recognised standard accepted by the Society.

4.4.3 A programme of tests and examination, based on the requirements of the applicable standard is to be submitted to the Society for approval.

For proof load tests provided in the programme of tests, the minimum proof load is to be greater than 1,5 the safe working load of the rope.

Breaking test may be required on case by case basis.

4.5 Sheaves

4.5.1 Sheaves construction and testing procedures are to be in accordance with the requirements of recognised standards accepted by the Society.

4.5.2 A programme of tests and examination is to be submitted to the Society for approval.

For proof load tests provided in the programme of tests, the minimum proof load is to be greater than 1,5 the safe working load of the sheave.

Breaking test may be required on case by case basis.

4.5.3 Safe working load for sheave

As a rule, this safe working load is defined for an angle by which the block turns the rope equal to 180°. When it is not the case, the value of the considered angle is to be defined with the value of the safe working load.

4.6 Wind propulsion system accessories

4.6.1 The present requirements are applicable to the attachment elements and connecting fittings between the different main safety and/or operating rigging parts.

4.6.2 Construction drawings of accessories are not required when standardized production is concerned, provided references of use in service are supplied to the Society satisfaction

For non-standard accessories, a technical file is to be submitted specifying technical characteristics and scantling criteria for approval.

4.6.3 As a rule, a programme of tests and examination is to be submitted to the Society for approval.

For proof load tests provided in the programme of tests, the minimum proof load is to be greater than 1,5 the safe working load of the accessories.

Breaking test may be required on case by case basis.

4.7 Ship hull interface accessories

4.7.1 The present requirements are applicable to the attachment elements and connecting fittings between the different main safety and operating rigging parts and ship hull structure.

The hull structure reinforcement in way of the interface accessories are to be examined as defined in Sec 8.

a) Chain plates and pad eyes:

- General:

Chain plates and pad eyes construction and testing procedures are to be in accordance with the requirements of the Rules of the Society or recognized standards.

- Tests:

A programme of tests and examination is to be submitted to the Society for approval.

For proof load tests provided in the programme of tests, the minimum proof load is to be greater than 1,5 SWL, where SWL as defined in Sec 5 for safety rigging element or in Sec 6 for operating rigging element.

Breaking test may be required on case by case basis.

- Standard product:

Construction drawings of chain plates and pad eyes are not required when standardized production is concerned, provided references of use in service are supplied to the Society satisfaction.

- Non standard products:

For non-standard chain plate and pad eyes, a technical file is to be submitted for information. This file is to include a detailed technical specification and scantling criteria (material characteristics, shear tear out, diametrical bearing pressure, welding...).

b) Other equipments (clutches, travelers):

- The following material specifications are to be submitted for information:

- type of material and composition
- maximum breaking and safe working loads
- expected service life.

- These equipments are to be in accordance with the requirements of recognized standard.

- A programme of tests and examination is to be submitted to the Society for approval.

For proof load tests provided in the programme of tests, the minimum proof load is to be greater than 1,5 SWL, where SWL as defined in Sec 6.

Breaking test may be required on case by case basis.

5 Certification requirements

5.1 General

5.1.1 A general document including the following information covering the rigging equipment defined in Article [4] is to be submitted to the Society for examination:

- recognised standards considered
- type of tests and documents stating the tests results
- type of certification process and certificate granted.

5.1.2 Certification requirements

Within the scope of the notations **WINDPROPULSION** and **WINDPROPULSION -OPR** the materials and equipment used in the construction of wind propulsion systems are subject to certification according to App 1.

Section 4 Environmental Conditions and Design Loads

1 General

1.1 Design loads

1.1.1 General case

This Section provides the design loads for the strength assessments of the wind propulsion system.

The overall design loads are to be derived from the:

- design load scenarios defined in Article [3]
- elementary design loads defined in Article [4]
- combination according to Article [5].

1.1.2 Specific case

On a case by case basis, the design loads for the strength assessments of the wind propulsion system may be deduced from a design wind heeling moment or a ship righting moment, according to [5.1.2].

2 Environmental conditions

2.1 Wind

2.1.1 Wind speed

Wind speed is speed of the wind measured at specified height above the sea level and averaged over a representative period, in m/s (see Fig 1).

The wind speed of constant wind is generally averaged over 10 minutes and calculated as follow:

$$V = \frac{1}{T} \int_0^T V(t) dt$$

The wind speed of gust is generally averaged over 3 seconds.

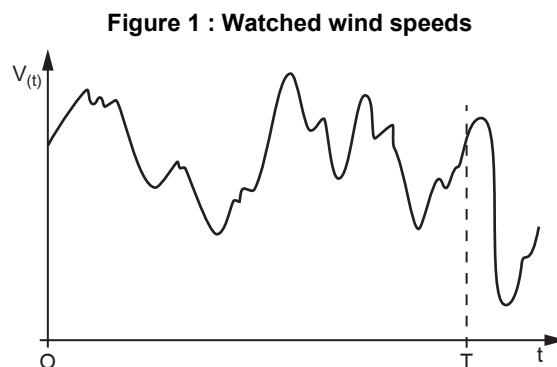

2.1.2 Wind speed sensors are to be provided to evaluate the weather conditions encountered with respect to the design conditions of the system.

They are to be fitted as far as possible at the upper part of the wind propulsion system and suitably located in order to avoid recording interference components of wind speed, such as:

- natural acceleration of flow in soft sails
- forced acceleration behind turbines
- turbulence in proximity to wing (especially at wing tip).

The measures are to be made continuously and corrected so as to reduce the momentarily steady overspeeds due to the ship rolling and pitching.

A minimum of two independent wind speed sensors dedicated to the wind propulsion system is to be installed. One of these sensors may be shared with the ship's existing meteorological or navigational instrumentation.

2.1.3 True wind

True wind is the wind measured on a solid body motionless with respect to the ground (see Fig 2).

True wind speed is to be described by wind speed distribution given by the following exponential variation law:

$$V(z) = V\left(\frac{z}{10}\right)^\alpha$$

where:

$V(z)$: True wind speed at height z , in m/s

α : Wind shear exponent, generally to be taken as:

- 0,14 for seagoing condition with the wind propulsion system in operation
- 0,11 for seagoing or harbour condition with the wind propulsion system in stand-by mode

V : True wind speed measured at 10 m above the sea level with:

- V not to be less than 36,01 m/s in seagoing conditions when the wind propulsion system is in stand-by mode
- V not to be less than 51,44 m/s in harbour conditions with the wind propulsion system in stand-by mode

z : Height above the sea level, in m.

Figure 2 : Apparent wind

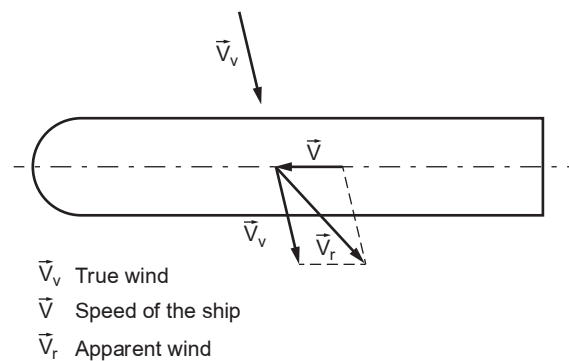

2.1.4 Apparent wind

Apparent wind is the wind measured on a moving solid body (for instance a ship), and is the result of the combination of the true wind and the wind induced by the own speed of the solid body.

It is the effect of the apparent wind which acts as wind propulsion of a ship, and thus it is the only one to be taken into consideration for structure scantlings assessment.

2.2 Sea state

2.2.1 The rule requirements for the scantling check of the safety rigging parts of the wind propulsion system are based on North Atlantic wave environment.

The ship motions and accelerations considered in the present Rule Note are given for a 25 years return period.

2.3 Snow and ice

2.3.1 Snow and icing are to be considered for wind propulsion system liable to operate in areas of snow and glazed frost as defined in NR467, Pt B, Ch 3, Sec 2, [6.4].

3 Design load scenarios for strength assessment

3.1 General

3.1.1 The design loads scenarios are defined as a combination of environmental and system conditions. The following scenarios are to be considered:

- a) Seagoing condition with the wind propulsion system in operation (OP-SEA):
Maximum wind and sea state conditions defined by the Designer in the operating manual for which the wind propulsion system can be operated.
- b) Seagoing conditions with the wind propulsion system in stand-by mode (SB-SEA):
Extreme wind as defined in [4.2.1]b) and accelerations as defined in [4.3.3]b) when the wind propulsion system is out of operation.
The Designer is to define the configuration of the wind propulsion system provided in extreme operating conditions (sails reefed or furled, lowered by telescopic or foldable system, tilting system, rotation of the wing...).

- c) Harbour conditions with the wind propulsion system in stand-by mode (SB-HAR):

Extreme wind as defined in [4.2.1)c) when the wind propulsion system is out of operation and ship is in harbour.

The Designer is to define the configuration of the wind propulsion system provided in harbour extreme conditions (sails reefed or furled, lowered by telescopic or foldable system, tilting system, rotation of the wing...).

3.1.2 When deemed necessary by the Society, accidental load, corresponding to abnormal system condition where the wind propulsion system is under unplanned configuration that result in activation of protection system and/or includes accidental loads scenario may be considered.

Accidental loads and conditions are to be identified following HAZID or FMECA outcomes results (See Sec 1, [1.4]).

4 Elementary design loads

4.1 General

4.1.1 As a rule, the elementary design loads to be considered for the wind propulsion system assessment for the different design load scenarios are to include:

- Lift and drag loads induced by apparent wind, specifying the associated combination of the wind propulsion system configurations and the wind angle of attack.
- Reaction forces on mast and boom induced by halyards or hooks, main sheet... and reaction forces on winch and platform induced by kite main cable
- Pre-tensioning forces, when applicable, provided in rigging elements (shrouds, stays...)
- Longitudinal, vertical and transversal inertia loads induced by ship motions.

In general, loads created by the hull girder deflection are negligible compared to the others, and are not taken into account. Anyhow, for particular arrangements, the Society may require that such loads are duly considered.

4.2 Wind loads

4.2.1 The wind load forces exerted on the structure of the wind propulsion system as defined in [4.1.1], items a) and b) are to be defined by the Designer and duly documented, specifying:

- a) For the design load scenario OP-SEA:

The load force distributions in relation to:

- the different configurations of the wind propulsion system in operation
- maximum apparent wind speed without gust effect, relative to the wind direction according the operating manual.

- b) For the design load scenario SB-SEA:

The load forces distributions in relation to:

- the configuration of the wind propulsion system in stand-by mode
- apparent wind speed considering a true wind speed not less than 70 knots, measured at 10 m above sea level and including gust effect.

When no information on ship speed in design load scenario SB-SEA is available, the apparent wind speed may be taken equal to 80 knots, measured at 10 m above sea level and including gust effect.

- c) For the design load scenario SB-HAR:

The load forces distributions in relation to:

- the configuration of the wind propulsion system in stand by mode
- true wind speed not less than 100 knots, measured at 10 m above sea level and including gust effect.

4.2.2 Wind force application

- a) Wind force calculation:

- General case:

The wind force resulting from the operating conditions of the wind propulsion system defined in [4.2.1] are to be deduced from a Computational Fluid Dynamics calculation (CFD), wind tunnel tests or by an equivalent calculation method to the satisfaction of the Society.

- Other cases:

Other method than CFD may be considered on a case by case by the Society, in particular when the wind force calculation are deduced from a design wind heeling moment. In this case, the design heeling moment, the angle of heel considered and the following information are to be submitted:

- maximum ship righting moment and corresponding heel angle
- calculation methodology considered to deduce the wind forces and their distribution exerted on the structure of the wind propulsion system according to [4.2.1]

- b) As a rule, the wind loads are to be applied on the structure model defined in Sec 5 as constant pressure or as punctual forces, as relevant.

4.3 Static and inertial forces induced by ship motions

4.3.1 General

a) General:

Static forces induced by the system own weight and ice accretions are to be considered in all seagoing and harbour conditions.

Inertial forces induced by ship motions and accelerations are to be considered for wind propulsion system in:

- design load scenario OP-SEA
- design load scenario SB-SEA

for full load and ballast loading conditions.

b) Wave angle of incidence:

The wave angles of incidence, as shown in Fig 3, are to be selected from the following wave incidences:

- Head sea and following sea: angle of incidence equal to 0° or 180°
- Beam sea: angle of incidence equal to 90° or 270°
- Forward oblique sea conditions: angle of incidence equal to 120° or 240°
- Following oblique sea conditions: angle of incidence equal to 60° or 300°

c) Wave angle of incidence to be considered:

As a rule, a minimum of three wave angle incidence cases are to be selected as follow:

- 1st case: maximum value of the longitudinal acceleration, selected from the incidences listed in b), with the transversal and vertical accelerations of the case considered
- 2nd case: maximum value of the vertical acceleration, selected from the incidences listed in b), with the transversal and longitudinal accelerations of the case considered
- 3rd case: maximum value of the transversal acceleration, selected from the incidences listed in b), with the vertical and longitudinal accelerations of the case considered.

When deemed necessary to the Society, additional cases may be requested depending on the wind propulsion geometry.

Figure 3 : Wave angle incidences

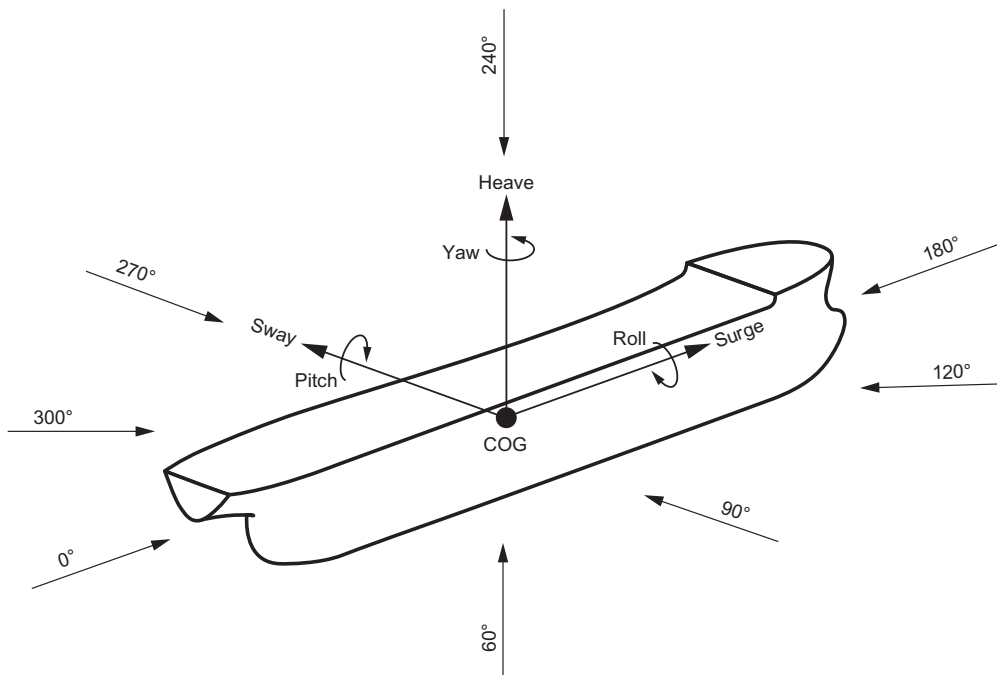

4.3.2 Static and inertial forces

a) Static force;

The static force applied on the elements of the wind propulsion system and which is to be taken into account for the scantling checks is:

$$F_{S,z,i} = -M_i g \text{ in vertical } z \text{ direction}$$

where:

- M_i : Mass of the elements considered, in tons, including the ice-added mass as defined in [4.4]
- g : Gravity acceleration, equal to 9,81 m/s²

b) Inertial forces calculation:

The inertial forces applied on the elements of the wind propulsion system and which are to be taken into account for the scantling checks are:

$F_{W,x,i} = M_i a_i$ in longitudinal x direction

$F_{W,y,i} = M_i a_i$ in transverse y direction

$F_{W,z,i} = M_i a_i$ in vertical z direction

where:

$F_{W,x,i}$, $F_{W,y,i}$, $F_{W,z,i}$: Dynamic forces in x, y and z direction respectively, in kN

M_i : Mass of the elements considered, in tons, including the ice-added mass as defined in [4.4]

a_i : Accelerations, in m/s^2 , at the center of gravity of the considered element:

- to be defined by the Designer according to [4.3.3)a) for the design load scenario OP-SEA
- to be as defined in [4.3.3)b) for the design load scenario SB-SEA

c) Inertial load application:

As a rule, the inertial loads are to be applied on the structure model defined in Sec 5 as pressure or as punctual forces, as relevant.

4.3.3 Accelerations

a) Accelerations in the design load scenario OP-SEA:

In the design load scenario OP-SEA limited by a maximum significant wave height, H_s , defined by the Designer in accordance with the operating manual, the accelerations considered to derive the inertial loads at any position are to be submitted and documented by the Designer.

When the values of the accelerations are not available from the Designer, the calculation approach defined in b) can be considered as a guideline for preliminary assessment of seagoing monohull displacement ships of conventional shape, speed and proportions.

In this case, the wave parameter coefficients defined in Tab 1 in relation to the H_s considered are to be taken into account to determine the ship motions.

b) Accelerations in the design load scenario SB-SEA:

The accelerations in the design load scenario SB-SEA used to derive the inertial loads at any position of the wind propulsion elements are defined in NR467, Pt B, Ch 5, Sec 3 [3.2].

These accelerations are based on the:

- ship motions as defined in NR467, Pt B, Ch 5, Sec 3 [2.1]: based on the wave parameter calculated with the coefficients defined in NR467, Pt B, Ch 5, Sec 3, Tab 1, the metacentric height and roll radius giration of the ship for the considered loading condition

Note 1: The metacentric height GM and roll radius of giration k_r are to be deduced from the actual loading conditions considered. When GM and K_r are unknown, these values may be taken as defined in NR467.

- accelerations of the ship at the centre of gravity as defined in NR467, Pt B, Ch 5, Sec 3 [2.2]
- position of the centre of the gravity of the considered elements of the wind propulsion system
- load combination factors to be applied to the accelerations as defined in NR467, Pt B, Ch 5, Sec 2 [2] based on the Equivalent Design Wave (EDW) concept.

Note 2: The EDW concept applies a consistent set of dynamic loads to the ship such that a specified dominant load response is equivalent to the required long term response value.

Ships other than seagoing monohull displacement ships of conventional shape, speed and proportions will be considered on a case by case by the Society. A direct long-term linear seakeeping analysis for a return period of 25 years, considering a North-Atlantic scatter diagram, may be required.

4.4 Ice**4.4.1 Ice load application**

a) Ice load calculation:

For ships operating in areas where ice accretion is likely to occur, the following icing weight to be applied to the wind propulsion system are to be considered:

- 30 kg per square metre on exposed horizontal surfaces
- 7,5 kg per square metre for the projected lateral area of each side of the wind propulsion system

Different amount of ice corresponding to local regulations or areas of navigation may be used instead of the above values.

The exposed areas are to consider the different positions of the wind propulsion system (position in service and tilted position when applicable).

b) Ice load application:

As a rule, the inertial loads induced by ice added-mass are to be applied on the structural model defined in Sec 5 as constant pressure or as punctual forces, as relevant.

Table 1 : Wave parameter H coefficients for strength assessment when sea state conditions are limited by H_s

H_s (1)	A_0	A_1	e_1	A_2	e_2	L_c
≤ 1,0 m	0,07	1,66	2,29	0,16	1,29	107,0
≤ 1,5 m	0,11	1,65	2,28	0,16	1,37	116,0
≤ 2,0 m	0,16	1,65	2,28	0,17	1,44	127,3
≤ 2,5 m	0,21	1,64	2,26	0,17	1,50	140,6
≤ 3,0 m	0,25	1,63	2,25	0,18	1,55	155,4
≤ 3,5 m	0,30	1,61	2,23	0,20	1,59	171,6
≤ 4,0 m	0,35	1,60	2,21	0,21	1,62	188,8
≤ 4,5 m	0,39	1,59	2,19	0,24	1,64	206,8
≤ 5,0 m	0,43	1,57	2,16	0,26	1,67	225,3
≤ 5,5 m	0,47	1,55	2,13	0,29	1,69	244,1
≤ 6,0 m	0,51	1,54	2,10	0,32	1,70	263,1
≤ 6,5 m	0,55	1,52	2,07	0,35	1,72	281,9
≤ 7,0 m	0,58	1,50	2,04	0,39	1,73	300,6
≤ 7,5 m	0,61	1,48	2,01	0,43	1,74	318,8
≤ 8,0 m	0,64	1,47	1,98	0,47	1,75	336,6
≤ 8,5 m	0,67	1,45	1,95	0,51	1,75	353,7
≤ 9,0 m	0,69	1,44	1,93	0,55	1,76	370,2
≤ 9,5 m	0,71	1,42	1,91	0,60	1,76	385,9
≤ 10,0 m	0,73	1,41	1,89	0,64	1,77	400,7

(1) H_s : Maximum significant wave height, in m, associated to the operating condition as defined by the Designer.

4.5 Pre-tensioning loads

4.5.1 When applicable, the pre-tensioning of the shrouds of the safety rigging parts is to be specified by the Designer. The application of the pre-tensioning on the structural model defined in Sec 5 is to be documented by the Designer.

4.6 Particular loads

4.6.1 Accidental loads

Accidental scenarios with loads not occurring during normal operations may be taken into account on a case by case basis when confirmed by a risk analysis.

4.6.2 Fatigue loads

When a fatigue capacity study of the wind propulsion system is carried out under the responsibility of the Designer, the loading conditions representative of the intended operation and the fraction of time spent in each condition are to be defined by the Designer and submitted to the Society for information.

The common loads to be considered for fatigue analysis are defined in [4.1.1]. For the different operating conditions, the constant and fluctuating loads induced by gust, ship motions and their frequency occurrence are to be considered.

5 Overall design loads

5.1 Design Load combinations

5.1.1 General case

The overall design loads to be considered for the stress assessment of the wind propulsion system are based on the combination of the elementary design loads defined in [4] taking into account the elementary load factors α defined in Tab 2.

When pre-tensioning loads are provided, these loads are to be combined with the elementary design loads.

5.1.2 Specific case

When the overall design loads for the strength assessments of the wind propulsion system are deduced from a design wind heeling moment or a design ship righting moment, the Designer is to submit the considered hypothesis according to one of the following calculation sequence a) or b):

a) Design wind heeling moment:

- values of apparent wind speeds including gust effects
- aerodynamic force values in relation to the different settings of the wind propulsion system
- heeling moment value and ship angle of heel
- calculation methodology to define the wind load forces distribution applied to the structure element of the wind propulsion system.

b) Design ship righting moment:

- value of ship righting moment and ship heel angle
- aerodynamic force values in relation to the different settings of the wind propulsion system
- values of apparent wind speeds including gust effects
- calculation methodology to define the wind load forces distribution applied to the structure element of the wind propulsion system.

The Designer is to justify the safety margin values considered between the design heeling or righting moment considered for the wind propulsion system scantling and the actual sailing conditions expected according to the condition navigation defined in the operating manual defined in Sec 1, [1.5.1]. The designer is to justify that these safety margin values are equivalent with the elementary load factors α defined in Tab 2.

- If deemed necessary by the Society, elementary design loads may have to be added to the overall design loads determined according to a) or b).

Table 2 : Elementary load factors α for design load combinations

SYSTEM IN OPERATION AT SEA (OP-SEA)					
Elementary design loads					
Wind loads			Static and inertial loads (1)		
Lift and drag loads induced by wind $\alpha_{w,ld}$	Reaction forces on mast $\alpha_{w,r}$ (4)		Mass of element $\alpha_{i,m}$	Ice added-mass $\alpha_{i,i}$	Acceleration $\alpha_{i,a}$
System condition	Apparent wind speed defined by the Designer		Ship motions and accelerations defined by the Designer or according to [4.3.3], item a)		
Intact	1,7 (3) (5)	1,05	1,05 (7)	1,0	1,3 (6)
Accidental (8)	1,0 (2)	1,0	1,05 (7)	1,0	1,0

SYSTEM IN STAND-BY MODE AT SEA (SB-SEA)					
Elementary design loads					
Wind loads			Static and inertial loads (1)		
Lift and drag loads induced by wind $\alpha_{w,ld}$ (2)	Reaction forces on mast $\alpha_{w,r}$ (4)		Mass of element $\alpha_{i,m}$	Ice added-mass $\alpha_{i,i}$	Acceleration $\alpha_{i,a}$
System condition	Apparent wind speed defined by the Designer considering a true wind speed not less than 70 knots as defined in [4.2.1] item b) (9)		Ship motions and accelerations as defined in [4.3.3], item b)		
Intact	1,0	1,0	1,05 (7)	1,0	1,0
Accidental (8)	1,0	1,0	1,05 (7)	1,0	1,0

SYSTEM IN STAND-BY MODE IN HARBOUR (SB-HAR)					
Elementary design loads					
Wind loads			Static and inertial loads (1)		
Lift and drag loads induced by wind $\alpha_{w,ld}$ (2)	Reaction forces on mast $\alpha_{w,r}$ (4)		Mass of element $\alpha_{i,m}$	Ice added-mass $\alpha_{i,i}$	Acceleration $\alpha_{i,a}$
System condition	True wind speed 100 knots as defined in [4.2.1] item c)		Ship motions and accelerations as defined in [4.3.3], item b)		
Intact	1,0	1,0	1,05 (7)	1,0	N.A.

- (1) As defined in [4.3].
- (2) Lift and drag loads induced by wind and their distribution induced by apparent wind with gusts effect, specifying the associated combination of the wind propulsion system configurations and the wind angle of attack.
- (3) Lift and drag loads induced by wind and their distribution induced by apparent wind without gusts effect, specifying the associated combination of the wind propulsion system configurations and the wind angle of attack. Loads induced by gusts are included in the load factor.
- (4) Reactions forces on mast as defined in [4.1.1], items b) and c).
- (5) When automatic release systems approved by the Society are provided to avoid wind overloads on the wind propulsion systems, as defined in Sec 7, [5.4.1], a value of 1,5 may be considered.
- (6) When direct calculation is performed for the acceleration calculations, a value of 1,15 may be considered. When automatic release systems, as defined in Sec 1, [2.2.5], approved by the Society, are provided to avoid inertial overloads on the wind propulsion systems, a value of 1,05 may be considered.
- (7) When weight report including sufficient margin is available, a value of 1,0 may be considered.
- (8) Accidental loads are to be defined on a case by case basis by risk analysis (HAZID or FMECA), if requested. Provided risk mitigation are taken, lower value of α may be considered by the Society on a case by case basis.
- (9) When no information on ship speed in design load scenario SB-SEA is available, the apparent wind speed may be taken equal to 80 knots, measured at 10 m above sea level and including gust effect.

Section 5 Safety Rigging Parts Structure

1 General

1.1 Application

1.1.1 The requirements of the present Section are applicable for the structure scantling check of the safety rigging parts of the wind propulsion system within the scope of the notation **WINDPROPULSION** or **WINDPROPULSION -OPR**.

The components and constituents of a safety rigging parts of a wind propulsion system are defined in Sec 1, [2.2.2] and Sec 1, Tab 2 according to the type of wind propulsion system considered.

1.1.2 The different materials considered in the present Section are:

- steel (ordinary or high tensile)
- aluminium alloys
- composites
- for shrouds, stays: Steel wire rigging, steel rod rigging and synthetic rigging.

Element of safety rigging parts built with other materials are to be specifically considered on a case by case basis.

2 Structure calculation approach

2.1 Structural model

2.1.1 General

The scantling check of the safety rigging parts is to be carried out on the basis of a 3D finite element calculation model or a beam model submitted by the Designer.

As a rule, the model is to take into account:

- the non-linear behaviour of safety rigging parts which result from the large deflection of the structure
- the linear behaviour of the material.

When deemed necessary by the Society, non-linear behaviour elements are to be considered in the model for components of the safety rigging parts (synthetic shroud and stays for example).

Other calculation approach may be considered by the Society on a case by case basis.

As a rule, the hull girder elastic deflection is not to be taken into account. However, if these deflections may affect the force reactions in the safety rigging, particularly in the shroud and stay pre-tensioning values considered for the calculations, the global hull structure deflection is to be considered for the calculation of the forces distribution in the safety rigging calculation.

2.1.2 Beam model

A beam model is made of beam elements, defined as line elements with axial, torsional, bi-directional shear and bending stiffness. Beam elements have constant properties along their length.

When a beam model is used for the structure check of the wind propulsion system, the beam torsional stresses induced by the eccentricity of the point of application of the beam forces from the neutral axis of the beams are to be considered in the beam model analysis.

2.1.3 Finite element model

The general types of finite elements to be used in finite element model are as follow:

a) Shell element:

- Standard mesh:

Element with in-plane stiffness and out-of-plane bending stiffness with constant thickness.

The shell elements mesh are to follow the stiffening system of the modelled safety rigging components considered as far as practicable, hence representing the actual plate panels between local reinforcements. As a rule:

- the size of elements is to be suitable to represent the concerned geometry where no stress concentration is expected
- the aspect ratio of shell elements is generally not to be greater than 2, and in no case greater than 4
- angles of quadrilateral elements are to be greater than 60° and less than 120°
- angles of triangular elements are to be greater than 30° and less than 120°.

- Fine mesh:

When a fine mesh is used for the analysis of structural details and for the evaluation of high stress in local areas:

- the size of the elements in the area of interest is not to be greater than 50 x 50 mm
- the extent of the refined area is to be at least of 5 elements in any direction around its centre.

- b) Beam element:

Line element with axial, torsional and bi-directional shear and bending stiffness and with constant properties along the length of the element.

- c) Rod element:

Line element with axial stiffness only and constant cross-sectional area along the length of the element.

2.2 Documentation to be submitted

2.2.1 General

- a) Model:

A document setting the hypothesis considered for the calculation model is to be submitted by the Designer for information, specifying:

- a complete representative safety rigging parts model geometry specifying for the different members contributing to the overall strength of the safety rigging parts their main characteristics (materials, mechanical characteristics, scantling)
- the orientation of the shell element co-ordinate system in relation to the reference co-ordinate system of the model
- the boundary conditions applied to the model (rotation and translation)
- the overall design load distribution
- the pre-tensioning forces provided in shrouds and stays
- the reference of the finite element analysis program used by the Designer.

- b) Results

A detailed report of the structural analysis is to be submitted by the Designer for information.

This report is to specify, for the different sailing operation conditions expected to occur, the following informations, as applicable, in relation with the type of wind propulsion system considered:

- global deflection of the safety rigging parts
- reaction forces and moments in way of the boundary conditions
- internal loads in the elements modelled with beams and rods, if any
- summaries and sufficient plots of stresses to demonstrate that the design criteria are not exceeded in any member
- buckling analysis and results
- proposed reinforcements to structure where necessary, including revised assessment of stresses and buckling showing compliance with design criteria.

3 Stress analysis

3.1 General

3.1.1 The stress analysis approach defined in the present Article takes into account:

- the type of element used in the model of the safety rigging parts, as defined in [2.1.2] and [2.1.3]
- the material.

3.1.2 The stress analysis approach defined in the present Article is to be corrected to take into account the stress concentrations in way of the safety rigging parts connections, accessories and structural discontinuities.

3.2 Stress analysis in shell elements made of steel and aluminium

3.2.1 Stress components

Stress components are generally identified with respect to the element co-ordinate system. The following stress components to be considered and calculated at the centroid of each element are:

- the normal stresses σ_1 and σ_2 in the directions of element co-ordinate system axes
- the shear stress τ_{12} with respect to the element co-ordinate system axes.

3.2.2 Stress calculation

The maximum stresses and buckling stresses are to be calculated as follow:

a) Maximum stress calculation:

The Von Mises equivalent stress, σ_{eq} , in N/mm², is to be derived as follows:

$$\sigma_{eq} = \sqrt{\sigma_1^2 + \sigma_2^2 - \sigma_1\sigma_2 + 3\tau_{12}^2}$$

Where σ_1 , σ_2 and τ_{12} are defined in [3.2.1].

b) Local buckling stress calculation:

Where the buckling panel is meshed by several finite elements, the stresses of the buckling panel are obtained by the following methodology:

- for each finite element, the stresses ($\sigma_{\xi e}^*$, $\sigma_{\psi e}^*$, τ_e^*) expressed in the element co-ordinate system are projected in the co-ordinate system of the buckling panel to obtained the stresses ($\sigma_{\xi e}$, $\sigma_{\psi e}$, τ_e).
- for the buckling panel, the stresses are calculated according to the following formula:

$$\sigma_x = \frac{\sum_i^n A_i \sigma_{x e_i}}{\sum_i^n A_i} \geq 0 \qquad \sigma_y = \frac{\sum_i^n A_i \sigma_{y e_i}}{\sum_i^n A_i} \geq 0$$

$$\tau = \frac{\sum_i^n A_i \tau_{e_i}}{\sum_i^n A_i} \geq 0$$

where:

- $\sigma_{x e_i}$, $\sigma_{y e_i}$: Stresses, in N/mm², of the finite element i, taken equal to 0 in case of tensile stress
- τ_{e_i} : Shear stress, in N/mm², of the plate finite element i
- A_i : Area, in mm², of the plate finite element i.

c) Column buckling stress calculation:

For mast shored up with shrouds and stays resulting in global compressive force on the mast, a column buckling check is to be carried out taking into account, for each parts of the mast between transversal support, the compressive forces deduced from the calculation.

The uniform compression stress, in N/mm², in the mast element is to be taken equal to:

$$\sigma_c = 10 \frac{P}{A}$$

where:

- P : Compressive force, in kN, deduced from the calculation
- A : Cross section, in cm², of the mast element considered.

3.3 Stress analysis in shell elements made of composite materials

3.3.1 General

The general calculation principle of composite panel is defined in NR546 "Hull in Composite Materials".

3.3.2 Stress components

Two main approaches are considered:

- a stress analysis in each individual layer of the composite panel ("ply by ply" analysis) in order to determine the following stresses in relation to the individual layer fibre direction:
 - main stresses (tensile, compressive and shear stresses), and
 - combined stresses.
- a stress analysis in the whole laminate panel in order to check the buckling behaviour of the composite panel.

3.3.3 Stress calculation

a) Main stresses:

The main stresses are to be calculated as follow:

- main tensile or compressive stresses σ_1 in the longitudinal direction of the fibre, mostly located in:
 - 0° direction of unidirectional tape
 - 0° and 90° directions of woven roving when the set of fibres are interweaved.

- main tensile or compressive stresses σ_2 in the perpendicular direction of the fibre, mostly located in:
 - 90° direction of unidirectional tape or combined fabrics when the set of fibres are stitched together without criss-crossing of fibre.
- main shear stresses parallel to the fibre located in the plane of the individual layer (τ_{12}) and/or between each individual layer (τ_{1L1} and τ_{1L2} , also designated as inter-laminar shear stresses).

b) Combined stresses:

- combined stresses calculated according to the Hoffman criterion as defined in NR546, Sec 2.

Note 1: Other combined stress criterion may be considered by the Society on a case by case basis.

c) Local buckling stresses:

- compression stresses in the longitudinal and transverse directions of the panel or structure element
- shear stresses in the plane of the panel or structure element.

d) Column buckling stress:

For mast shored up with shrouds and stays resulting in compressive force on the mast, a column buckling check is to be carried out taking into account, for each parts of the mast between transversal support, the compressive forces deduced from the calculation.

The uniform compression stress, in N/mm², in the mast element is to be taken equal to:

$$\sigma_c = 10 \frac{P}{A}$$

where:

P : Compressive force, in kN, deduced from the calculation

A : Cross section, in cm², of the mast element considered.

3.4 Stress analysis in beam elements made of steel and aluminium

3.4.1 The equivalent stress, in N/mm², to take into account at the middle of the element length is to be taken equal to:

$$\sigma_{eq} = \sqrt{\sigma_x^2 + 3\tau^2}$$

where:

σ_x : $\sigma_x = \sigma_a + \sigma_b$

σ_a : Axial stress induce by the global bending and compressive forces applied to the mast.

σ_b : Bending stress induced by the local loads applied to the stiffener where applicable

τ : Shear stress induced by the local loads applied to the stiffener where applicable.

3.5 Stress analysis in beam elements made of composite materials

3.5.1 The global stress σ_{Av} in N/mm², and the longitudinal strain ϵ_{Aref} in %, in the stiffener modeled by beam are to be deduced from the 3D model.

The global stress σ_{Ai} in N/mm², and strain ϵ_{Air} in %, in the basic elements of the stiffener (associated plate, web and flange) in the longitudinal axis of the stiffener are to be calculated as follow:

$$\sigma_{Ai} = \frac{E_i}{100} \epsilon_{Aref}$$

$$\epsilon_{Ai} = \frac{100}{E_i} \sigma_{Ai}$$

where:

E_i : Main moduli of the basic element of the stiffener, in the longitudinal axis of the stiffener, in N/mm², as defined in NR546, Sec 6.

The local stresses, in N/mm², in each layer of the laminates of the basic elements, in their local axes, are to be calculated according to NR546, Sec 7 [3.2].

3.6 Stress analysis in rod elements

3.6.1 The axial stress σ_{axial} in N/mm², is to be calculated based on the axial loads at the middle of the element length.

4 Scantling check

4.1 General

4.1.1 The scantling check defined in the present Article is based on:

- the type of element used in the model of the safety rigging parts, as defined in [2.1.2] and [2.1.3]
- the material.

4.2 Scantling check of items modeled as shell elements made of steel and aluminium

4.2.1 The following criteria are to be checked:

a) Yield criteria:

The Von Mises equivalent stress σ_{eq} defined in [3.2.2], item a) is to be in compliance with the following formula:

$$\sigma_{eq} \leq \frac{R_y}{\gamma_m \gamma_R}$$

where:

- R_y : Minimum yield stress, in N/mm², as defined in Sec 3
- γ_m : Material factor to be taken equal to 1,02
- γ_R : Resistance factor to be taken equal to:
- 1,2 for standard mesh shell elements
 - for fine mesh shell elements:
 - 0,8 for elements adjacent to the weld
 - 0,7 for elements not adjacent to the weld.

In addition, the following requirements apply to fine mesh shell elements:

- When a mesh size lower than 50 x 50 mm is used, the average stress within an area equivalent to 50 x 50 mm² is to comply with the requirements for fine mesh analysis.
- The average stress within an area equivalent to the standard mesh size is to comply with the requirements for standard mesh analysis. When the structural arrangement is not compatible with the standard mesh definition as given in [2.1.3], this average stress criterion is to be verified within an area equivalent to the minimum extent of the refined area as defined in [2.1.3].

b) Local buckling criteria:

The buckling acceptance criteria is defined as follow:

$$\eta_{act} \leq \eta_{all}$$

where:

- η_{all} : Allowable buckling utilisation factor equal to:
- $$\eta_{all} = 1 / (\gamma_m \gamma_R)$$
- γ_m : Material factor to be taken equal to 1,02
- γ_R : Resistance factor to be taken equal to 1,6.

Note 1: For safety rigging structure element that does not affect the overall safety rigging integrity from buckling point of view, the factor γ_R may be taken equal to 1,2.

- η_{act} : ratio of the applied equivalent stress and the corresponding buckling capacity

$$\eta_{act} = \frac{1}{\gamma_c}$$

- γ_c : Minimum stress multiplier factors γ_{ci} at plate limit state for each of the different limit states as calculated according to the following interaction formulae as defined in NR615:

For plate stiffened panel, η_{act} may be defined as follow:

$$\left(\frac{\gamma_{c1} \sigma_x S}{\sigma_{cx}} \right)^{e_0} + \left(\frac{\gamma_{c1} \sigma_y S}{\sigma_{cy}} \right)^{e_0} + \left(\frac{\gamma_{c1} |\tau| S}{\tau_c} \right)^{e_0} - \Omega = 1$$

with:

$$\Omega = B \left(\frac{\gamma_{c1} \sigma_x S}{\sigma_{cx}} \right)^{e_0/2} \left(\frac{\gamma_{c1} \sigma_y S}{\sigma_{cy}} \right)^{e_0/2}$$

- when $\sigma_x \geq 0$ (compressive):

$$\left(\frac{\gamma_{c2} \sigma_x S}{\sigma_{cx}} \right)^{2/\beta_p^{0,25}} + \left(\frac{\gamma_{c2} |\tau| S}{\tau_c} \right)^{2/\beta_p^{0,25}} = 1$$

- when $\sigma_y \geq 0$ (compressive):

$$\left(\frac{\gamma_{c3} \sigma_y S}{\sigma'_{cy}}\right)^{2/\beta_p^{0,25}} + \left(\frac{\gamma_{c3} |\tau| S}{\tau'_c}\right)^{2/\beta_p^{0,25}} = 1$$

- $\frac{\gamma_{c4} |\tau| S}{\tau'_c} = 1$

Note 2: In the present formula, compressive and shear stresses are to be taken as positive, tension stresses are to be taken as negative.

where:

σ_x, σ_y, τ : Normal and shear stresses applied on the plate panel, in N/mm², deduced from the calculation and to be taken as defined in [3.2.2] item b)

σ'_{cx} : Ultimate buckling stress, in N/mm², in the direction parallel to the longer edge of the buckling panel, as defined in NR615, Sec 5

σ'_{cy} : Ultimate buckling stress, in N/mm², in the direction parallel to the shorter edge of the buckling panel, as defined in NR615, Sec 5

τ'_c : Ultimate buckling shear stresses, in N/mm², as defined in NR615, Sec 5

$\gamma_{c1}, \gamma_{c2}, \gamma_{c3}, \gamma_{c4}$: Stress multiplier factors at plate limit state for each of the above different limit states.

γ_{c2} and γ_{c3} are to be considered only when $\sigma_x \geq 0$ and $\sigma_y \geq 0$, respectively

S : Partial safety factor to be taken as:

- for structure exposed to local concentrated loads: S = 1,1
- for other cases: S = 1,0

B, e₀ : Coefficients given in Tab 1.

c) Column buckling criteria:

For mast shored up with shrouds and stays resulting in global compressive force on the mast, a column buckling check is to be carried out taking into account, for each parts of the mast between transversal support, the compressive forces deduced from the calculation.

The compression stress σ_c is to be in compliance with the following formula:

$$\sigma_c \leq \frac{\sigma_{CB}}{\gamma_m \gamma_R}$$

where:

γ_m : Material factor to be taken equal to 1,02

γ_R : Resistance factor to be taken equal to 1,6

Note 3: For safety structure element that do not affect the overall safety rigging part integrity from buckling point of view, the factor γ_R may be taken equal to 1,2.

σ_{CB} : Critical column buckling, in N/mm² in the mast element submitted to compression, in N/mm², calculated by the finite element software and documented by the Designer or obtained from the following formulae:

$$\sigma_{CB} = \sigma_{E1} \quad \text{for } \sigma_{E1} \leq \frac{R_{eH}}{2}$$

$$\sigma_{CB} = R_{eH} \left(1 - \frac{R_{eH}}{4\sigma_{E1}}\right) \quad \text{for } \sigma_{E1} > \frac{R_{eH}}{2}$$

σ_{E1} : Euler column buckling stress, to be obtained, in N/mm², from the following formula:

$$\sigma_{E1} = \pi^2 E \frac{I}{A(f\ell)^2} 10^{-4}$$

I : Moments of inertia, in cm⁴, of the mast element with regard to the main axis of the mast

A : Cross-sectional area, in cm², of the mast element

ℓ : Span, in m, of the mast element between lateral support with regard to the main axis of the mast

f : Coefficient taking into account the boundary conditions of the mast element ends in way of the transversal supports and to be taken equal to:

- for both ends pinned: f = 1
- for one end fixed and the other end pinned: f = 0,7.
- for one end fixed and the other free: f = 2

Table 1 : Coefficient B and e₀

Applied stresses	B	e ₀
$\sigma_x \geq 0$ and $\sigma_y \geq 0$	$0,7 - 0,3 \beta_p / \alpha^2$	$2 / \beta_p^{0,25}$
$\sigma_x < 0$ or $\sigma_y < 0$	1,0	2,0

Note 1:

α : Aspect ratio of the plate panel, to be taken as:

$$\alpha = \frac{a}{b}$$

a : Length of the longer side of the plate panel, in mm
 b : Length of the shorter side of the plate panel, in mm
 β_p : Plate slenderness parameter taken as:

$$\beta_p = \frac{b}{t_p} \sqrt{\frac{R_{eH,P}}{E}}$$

t_p : Thickness of the plate panel, in mm.

4.3 Scantling check of items modeled as shell elements made of composite materials

4.3.1 General

The structure scantling criteria are based on the actual safety coefficients equal to the ratio between:

- for main stresses and combined stresses: the theoretical breaking stresses of each individual layers of laminates (as defined in NR546, Sec 5) and the actual stresses deduced from a finite calculation (see [4.3.2] and [4.3.3])
- for buckling stresses: the critical buckling stress of the whole laminate (as defined in NR546, Sec 6), and the actual stresses deduced from a finite calculation (see [4.3.4] and [4.3.5]).

In local areas where a fine mesh is used in the finite element model as defined in [2.1.3] a), the safety coefficients defined in [4.3.2] and [4.3.3] are to be reduced by 10%.

When the actual stress are deduced from a beam calculation as defined in [2.1.2], the safety coefficients defined in [4.3.2] and [4.3.3] are to be increased by 10%.

4.3.2 Main stresses in individual layers

The main stresses in each ply are to be in compliance with the following criteria:

$$\frac{\sigma_{bri}}{\sigma_{iapp}} \geq SF$$

where:

σ_{bri} : In-plane theoretical individual layer breaking stresses defined in NR546, Sec 5, [5]

σ_{iapp} : In-plane individual layer applied stresses

SF : Minimum stress criterion in layers to be taken equal to:

$$SF = C_v C_F C_R$$

C_v, C_F, C_R: Partial safety coefficients as per item [4.3.6].

4.3.3 Combined stresses in individual layers

The safety factor for the combined stresses in each ply is to be in compliance with the following criteria:

$$SF_{CS} \geq SF_{CSiapp}$$

where:

SF_{CSiapp} : Actual combined stress applied in layer as calculated in NR546, Sec 2, [1.3.3].

SF_{CS} : Minimum safety coefficient equal to:

$$SF_{CS} = C_v C_F C_{CS}$$

C_v, C_F, C_{CS}: Partial safety coefficients as per item [4.3.6].

4.3.4 Local buckling stresses

The local buckling stresses in the whole laminate are to be in compliance with the following criteria:

$$\frac{\sigma_c}{\sigma_A} \geq SF_B$$

where:

σ_c : Ultimate buckling stress, in N/mm², calculated by the finite element software. These values are to be documented by the Designer.

σ_A : Compressive stress applied to the whole laminate considered calculated according to [3.3.3], item c)

SF_B : Minimum stress criterion in layers to be taken equal to:

$$SF_B = C_V C_F C_{Buck}$$

C_V, C_F, C_{Buck} : Partial safety coefficients as per item [4.3.6].

4.3.5 Column buckling stresses

For mast shored up with shrouds and stays resulting in global compressive force on the mast, a column buckling check is to be carried out taking into account, for each parts of the mast between transversal support, the compressive forces deduced from the calculation.

The global buckling stresses in the whole laminate are to be in compliance with the following criteria:

$$\frac{\sigma_{cg}}{\sigma_A} \geq SF_B$$

where:

σ_{cg} : Critical global buckling stress to be taken equal to:

$$\sigma_{cg} = \pi^2 \frac{[EI]}{A(f\ell)^2} 10^{-6}$$

σ_A : Compressive stress applied to the whole laminate considered calculated according to [3.3.3], item c)

ℓ : Span, in m, of the mast element between lateral support with regard to the main axis of the mast

f : Coefficient taking into account the boundary conditions of the mast element ends in way of the transversal supports and to be taken equal to:

- for both ends pinned: $f = 1$
- for one end fixed and the other end pinned: $f = 0,7$.
- for one end pinned and the other free: $f = 2$

A : Global transverse section of the pillar, in mm^2

$[EI]$: Global bending rigidity of the pillar in its main axis, in N/mm^2 .

SF_B : Minimum stress criterion in layers to be taken equal to:

$$SF_B = C_V C_F C_{Buck}$$

C_V, C_F, C_{Buck} : Partial safety coefficients as per item [4.3.6].

4.3.6 Partial safety coefficients

The partial safety factors are to be taken at least equal to:

a) ageing effect factor C_V :

C_V takes into account the ageing effect of the composites and is generally taken equal to 1,1.

b) fabrication process factor C_F :

C_F takes into account the fabrication process and the reproducibility of the fabrication and is generally taken equal to:

$C_F = 1,10$ in case of a prepreg process

$C_F = 1,15$ in case of infusion and vacuum process

$C_F = 1,00$ for the core materials of sandwich composite

c) type of stress factor C_R :

C_R takes into account the type of stress in the fibres of the reinforcement fabrics and is generally taken equal to:

1) For fibres of the reinforcement fabrics:

- for tensile or compressive stress parallel to the continuous fibre of the reinforcement fabric:

$C_R = 2,1$ for unidirectional tape, bi-bias, three-unidirectional fabric

$C_R = 2,4$ for woven roving

- for tensile or compressive stress perpendicular to the continuous fibre of the reinforcement fabric:

$C_R = 1,25$ for unidirectional tape, bi-bias, three-unidirectional fabric

- for shear stress parallel to the fibre in the elementary layer and for interlaminar shear stress in the laminate:

$C_R = 1,6$ for unidirectional tape, bi-bias, three-unidirectional fabric

$C_R = 1,8$ for woven roving

- for mat layer:

$C_R = 2,0$ for tensile or compressive stress in the layer

$C_R = 2,2$ for shear stress in the layer and for interlaminar shear stress

2) For core materials:

- for tensile or compressive stress for cores:

- in the general case:

$C_R = 2,1$ for tensile or compressive stress

- for balsa:

$C_R = 2,1$ for tensile or compressive stress parallel to the wood grain

$C_R = 1,2$ for tensile or compressive stress perpendicular to the wood grain

- for shear stress, whatever the type of core material:

$C_R = 2,5$

- d) combination stress factor C_{CS} :

$C_{CS} = 1,7$ for unidirectional tape, bi-bias, three-unidirectional fabric

$C_{CS} = 2,1$ for the other types of layer

- e) buckling factor C_{BUCK} :

$C_{BUCK} = 1,45$

Note 1: For safety rigging structure element that do not affect the overall safety rigging integrity from buckling point of view, the factor C_{BUCK} may be taken equal to 1,1.

4.4 Scantling check of items modeled as beam elements made of steel and aluminium

4.4.1 The following criteria are to be checked:

- a) Maximum stresses:

The Von Mises equivalent stress σ_{eq} defined in [3.4.1] is to be in compliance with the following formula:

$$\sigma_{eq} \leq \frac{R_y}{\gamma_m \gamma_R}$$

where:

R_y : Minimum yield stress, in N/mm², as defined in Sec 3

γ_m : Material factor to be taken equal to 1,02

γ_R : Resistance factor to be taken equal to 1,3

- b) Buckling stresses:

The global column buckling stress and the local buckling stress of the basic elements of the stiffener (flange, web and associated plating) are to be checked taking into account the axial stress induced by the bending and compressive forces applied to the mast and the acceptance criteria γ_m and γ_R defined in [4.2.1], item b).

4.5 Scantling check of items modeled as beam elements made of composite material

4.5.1 The following criteria are to be checked:

- a) Maximum stresses and combined stresses:

The maximum stresses and the combined stresses in the basic elements of the stiffener (associated plate, web flange) are to fulfil the requirements defined in [4.3.1], [4.3.2] and [4.3.3].

- b) Buckling stresses:

Where deemed necessary by the Society, the column buckling stress and the local buckling stress of the basic elements of the stiffener (flange, web and associated plating) are to be checked taking into account the acceptance criteria defined in [4.3.4] and [4.3.5].

4.6 Scantling check of items modeled as rod elements

4.6.1 The following criteria applies to shrouds, fore and backstays, running backstay and their terminal accessories (end fittings, turnbuckles...), which are modeled as rod elements in the calculation model and considered as safety rigging parts, as defined in Sec 1, [2.2].

The minimum breaking force (MBF), in kN, of shrouds, stays... and their terminal accessories is to comply with the following criteria:

$$MBF \geq \eta \cdot F$$

where:

MBF : Minimum breaking load defined in Sec 6

F : The SWL of the cable and terminal accessories, to be taken at least equal to the maximum static tension, in kN, deduced from the model calculations as defined in Article [2]

η : Safety factor defined in Tab 2.

Table 2 : Safety factor η

Type of cable and terminal accessories	Safety factor η
Steel wire	3,0
Steel rod	2,5
Carbone	3,0
Polybenzoxazole (PBO)	4,0
Hight modulus polyethylen	3,0

4.7 Scantling check of mast rotating systems

4.7.1 When mast rotating systems are parts of the safety rigging, an attestation issued by the ring manufacturer giving the permissible values for overturning moment and vertical force in the design load scenarii SB-SEA and SB-HAR is to be submitted to the Society.

These values are not to be lower than those calculated according to the calculation approach defined in Article [2] increased by 10%.

5 Scantling check for safety rigging parts connections

5.1 Application

5.1.1 The requirements of the present Article apply for the scantling of mechanical connections of safety rigging parts.

5.2 Welding and weld connections

5.2.1 As a rule, the general requirements for the preparation, execution and scantling of welded connections are to be in accordance with the principles defined in the NR467, Pt B, Ch 13.

5.2.2 The main principles of weld connections between main elements of the safety rigging parts are:

- fillet welds and butt welds are to be continuous and butt welds are to be full penetration
- the throat thickness of the double fillet welds on T connections is to be in general neither lower than 3,5 mm nor higher than 0,7 times the thickness of the thinnest plate of the assembly. Full penetration welds may be required for highly stressed elements.

Other arrangements may be examined on a case by case basis.

5.2.3 When fillet weld scantling is determined by direct calculation, the fillet weld scantling is to be based on the scantling criteria defined in the present Section for the considered plates of the assembly.

5.3 Bolting connections

5.3.1 General

As a rule, the arrangement and scantling of bolted connections are to be checked by direct calculation and are to comply with a recognized standard.

5.3.2 The effective cross-sectional area (nominal stress area) to be taken into account for the bolting connection scantling, in mm², of the threaded part of a bolt is to be taken as equal to the following value:

$$S_b = \frac{\pi}{4}(d_b - 0,94 p)^2$$

where:

d_b : Nominal bolt diameter, in mm

p : Thread pitch, in mm.

If the diameter of the screw body is less than $d_b - 0,94p$ the nominal stress area of the bolt is to be taken as equal to the cross-sectional area of the screw body.

If the thread pitch is not indicated, it is assumed that it is an ISO metric threading complying with the ISO standard 898-1 of which are specified in Tab 3 according to the nominal diameter of the bolt.

5.3.3 The tightening of bolts is to be checked by suitable means and the pre-stress applied is to be between 70% and 90% of the yield stress of the bolts used.

When the tightening is checked by measuring the torque applied, then the value of this torque is to be specified. If the value, in daN.m, is not included between the minimum value C_{min} and the maximum value C_{max} , given hereunder, relevant explanations may be requested:

$$C_{min} = 0,14 \cdot 10^{-4} S_b d_b R_e$$

$$C_{max} = 0,16 \cdot 10^{-4} S_b d_b R_e$$

where:

- S_b : Nominal stress area, in mm², of the bolt as per [5.3.2]
- d_b : Nominal diameter, in mm, of the bolt
- R_e : Yield stress, in N/mm², of the bolt corresponding to its steel quality grade (see Sec 3, [3.2]).

Here above values for tightening torques are valid for bolts (screws, nuts and washers) suitably cleaned, without dust or rust, and slightly oiled.

Note 1: Bolt tightening for bolted connections on composite materials are to be examined on a case by case basis.

5.4 Riveting connections

5.4.1 As a rule, the arrangement and scantling of riveting connections are to be checked by direct calculations and are to comply with a recognized standard.

Table 3 : ISO metric thread value of thread pitch

Nominal diameter d_b of the bolt, in mm			Thread pitch (coarse thread) p , in mm
10			1,50
12			1,75
14	16		2,00
18	20	22	2,50
24	27		3,00
30	33		3,50
36	39		4,00

5.5 Bonded connections

5.5.1 General

As a rule, bonded connections are examined by direct calculations taking into account the shear force applied to the bonded joints deduced from the calculation, the surface of the joint, and the joint characteristics determined as defined in Sec 3, [3.4].

Where structure connection is submitted to tension or out of plane forces (cleavage, peel...) due to the joint geometry, or where adhesive with shear elongation at break greater than 10% is used, the bonded connection is to be examined on a case by case basis.

5.5.2 Scantling check

The safety factor equal to the ratio between the theoretical shear breaking stresses of the bonded joint defined in Sec 3, [3.4.2] and the actual applied shear stress in the connection is to fulfil the following condition:

$$SF \geq 2,4 C_t C_v C_F C_{T_p} \geq 4$$

where:

- C_t : Safety factor considered for the shear breaking stress as determined by mechanical tests according to Sec 3, [3.4.2] and Sec 3, [3.4.3].
 C_t is to be taken equal to 1,2.

- C_v : Factor taking into account the ageing effect, to be taken at least equal to 1,2.

Note 1: When the joint is directly exposed to UV and/or water, the value of C_v is to be determined by ageing tests

- C_F : Factor taking into account the gluing process and post control and generally taken as follows:
 - $C_F = 1,25$ in case of manual process
 - $C_F = 1,15$ in case of a vacuum process, infusion or equivalent

Note 2: The post control plan is to be submitted to the Society.

- C_{T_p} : Factor taking into account the temperature in service condition, to be taken equal to:
 - $C_{T_p} = 1$ when the joint is tested in laboratory with the min/max temperature provided in service
 - $C_{T_p} = 1,2$ when the mechanical characteristics of the joint at the min/max temperature provided in service are deduced from technical data sheets submitted by the adhesive supplier.

6 Scantling check for safety rigging parts accessories

6.1 General

6.1.1 The requirements of the present Article apply for the scantling check of accessories and connecting fittings fixed to the safety rigging parts.

The accessories and connecting fittings considered are the main attachment elements and connecting fittings between the different safety rigging element equipments, essential to the overall structure integrity of wind propulsion system.

The manufacturing and testing connections are to be as defined in Sec 3, [4.6].

Scantling check of the safety rigging parts accessories are to be based on the maximum load in the elements as deduced from the model calculation defined in Article [2], combined with one of the following scantling approaches:

- based on the element breaking load, as given in [6.2.1]
- based on the calculated stress in the element, as given in [6.2.2].

6.2 Scantling check

6.2.1 Scantling based on the element breaking load

The scantling check of the element based on its breaking load value is to fulfil the following criteria:

$$MBF \geq \eta \cdot F$$

where:

MBF : Minimum breaking load of the element

F : Maximum load in the safety rigging parts attached to the equipment, in kN, deduced from the model calculation as defined in Article [2]

η : Safety factor to be taken not less than:

- 3,5 for creeping-sensitive component
- 2,4 for non creeping-sensitive element.

6.2.2 Scantling based on the calculated stress in the element

The scantling check of the element based on calculation approach is to fulfill the following criteria:

$$\sigma_{eq} \leq \frac{R_y}{\gamma_m \gamma_R}$$

where:

σ_{eq} : Von Mises equivalent stress, in N/mm² induced by the load in the safety rigging parts attached to the equipment deduced from the model calculation as defined in Article [2].

R_y : Minimum yield stress of the equipment, in N/mm², as defined in Sec 3

γ_m : Material factor to be taken equal to 1,02

γ_R : Resistance factor to be taken as defined in Tab 4:

For components built in composite materials, the main stresses and the combined stresses are to comply the criteria defined in [4.3.1], [4.3.2] and [4.3.3] respectively with SF and SF_{CS} increased by 20%.

Table 4 : Resistance factor γ_R

Type of element used in the model		Creeping-sensitive element	Non creeping-sensitive element
Beam elements		2,10	1,45
Standard mesh shell elements		1,90	1,35
Fine mesh shell elements (1)	Elements adjacent to the weld	1,30	0,90
	Elements not adjacent to the weld	1,10	0,80

(1) In addition, the following requirements apply to fine mesh shell elements:

- When a mesh size lower than 50 x 50 mm is used, the average stress within an area equivalent to 50 x 50 mm² is to comply with the requirements for fine mesh analysis.
- The average stress within an area equivalent to the standard mesh size is to comply with the requirements for standard mesh analysis. When the structural arrangement is not compatible with the standard mesh definition as given in [2.1.3], this average stress criteria is to verified within an area equivalent to the minimum extent of the refined area as defined in [2.1.3].

7 Scantling check for ship hull interface accessories

7.1 General

7.1.1 The interface components between the ship hull and the safety rigging parts (chain plate, pad eye or equivalent devices) are to fulfil the requirements defined in [6].

Local ship hull reinforcements in way of the ship hull interface accessories are to be as defined in Sec 8.

8 Deflection

8.1 Maximum horizontal deflection

8.1.1 When relevant, the acceptability of deflections are to be considered under operating conditions. Acceptability criteria are to be defined by the Designer.

9 Vibration

9.1 General

9.1.1 The main origins of vibratory excitation sources of the wind propulsion system are:

- ship induced sources:
 - engine and propeller installations
 - hydraulic or electric energy production installation
 - mechanical installations inherent to wind propulsion system (ventilators, turbines, etc...).
- external sources
 - variations of wind instantaneous speeds
 - induced vibratory phenomenon (for instance Van Karman vortices).

It is the builder's responsibility to evaluate, if deemed necessary, the risk of resonance of the wind propulsion system, and the possible vibratory level.

10 Fatigue

10.1 General

10.1.1 It is the Builder's responsibility to carry out an assessment of the fatigue capacity of the wind propulsion system and critical structural details under fluctuating stresses.

The critical details identified by the fatigue analysis and subject to periodical inspections are to be listed in the maintenance manual defined in Sec 1, [1.5.2].

Section 6 Operating Rigging Parts Structure

1 General

1.1 Application

1.1.1 General

The requirements of the present section are applicable for the scantling check of the operating rigging parts within the scope of the notation **WINDPROPULSION -OPR**.

The components and constituents of an operating rigging parts are defined in Sec 1, [2.2.3] and Sec 1, Tab 2 according to the type of wind propulsion system considered.

1.2 Documentation to be submitted

1.2.1 General

The documentation to be submitted to define the general arrangement of the operating rigging parts is defined in Sec 2, Tab 3.

A general arrangement drawing of the operating rigging parts specifying the following informations is to be submitted:

- positions of winches and clutches
- positions of tracks, padeyes
- arrangement of sail sheets and halyards specifying the change of angles in way of blocks
- details of ship hull interface accessories (blocks, padeyes, winches...).

A table is to be submitted by the Designer, specifying the forces applied to the operating rigging parts in the different wind propulsion system configurations deduced from the calculations method defined in Article [2] or by an equivalent calculation method.

1.2.2 For each operating rigging parts, the following documents are to be submitted to the Society for information:

- technical specifications as defined in Sec 3
- structure drawings of elements such as boom, mast rotating systems, wing orientable systems... when applicable.
- manufacturer's documents stating the results of the tests performed on the equipment and product certificate.

2 Calculation methods

2.1 Application

2.1.1 Loads

The loads in the operating rigging parts deduced from the calculation method defined in Sec 5, [2] are to be calculated taking into account the elementary load factors α considered in the overall designed loads defined in Sec 4, [5].

When the loads in the operating rigging parts are deduced from an equivalent calculation method, the Designer is to justify the calculation approach.

2.1.2 Load on sheave blocks

As a rule, the load on sheave blocks is to be determined on the basis of vectorial composition of force exerted by the rope taking into account the angle by which the block turns the rope.

The maximum load on a sheave block is obtained for an angle equal to 180° and is equal to 2 times the tensile rope force.

3 Scantling check for operating rigging parts

3.1 General

3.1.1 Reference loads

The reference loads to be considered for the scantling check of the operating rigging parts are to be based on:

- a) for sail sheets and halyards, clutch, sheaves: the breaking load MBL of the element, or the maximum load in the element deduced from the calculation approach defined Sec 5, [2]

Note 1: The minimum breaking force of an element is the static force in kN, corresponding to its minimum load which causes its breaking.

- b) for winch: the brake value of the winch
- c) for boom: the loads deduced from the calculation approach defined in Article [2]

Note 2: Integrated long boom for balestron rig or soft wing sails rig is to be considered as safety rigging parts and is to be examined according to Sec 5.

- d) mast rotating systems: the loads deduced from the calculation approach defined in Article [2]

Note 3: When the mast rotating system is a part of a set of an automatic release system to avoid wind overload or used for safeguarding the wind propulsion system in extreme environmental conditions, the mast rotating system is to be considered as safety rigging parts and is to be examined according to Sec 5.

3.2 Scantling criteria for operating rigging parts

3.2.1 Scantling based on the element breaking load

The scantling check is to fulfill the following criteria:

$$MBF \geq \eta \cdot F$$

where:

- MBF : Minimum breaking force, in kN, of the considered element
- F : The maximum load, in kN, as defined in [3.1.1]
- η : Safety factor to be taken not less than:
 - 3,1 for creeping-sensitive elements
 - 2,1 for non creeping-sensitive elements

Note 1: For fiber ropes of materials other than polyester and HMPE (High Modulus Polyethylene), the minimum values of safety factors are to be increased in the rope itself (i.e. not including other parts of the line) by 10%.

3.2.2 Scantling based on the calculated stress in the element

The scantling check is to fulfill the following criteria:

$$\sigma_{eq} \leq \frac{R_y}{\gamma_m \gamma_R}$$

where:

- σ_{eq} : Von Mises equivalent stress, in N/mm² induced by the load defined in [3.1.1]
- R_y : Minimum yield stress of the equipment, in N/mm², as defined in Sec 3
- γ_m : Material factor to be taken equal to 1,02
- γ_R : Resistance factor to be taken as defined in Tab 1.

For components built in composite materials, the main stresses and the combined stresses are to comply the criteria defined in Sec 5, [4.3.1], Sec 5, [4.3.2] and Sec 5, [4.3.3].

When deemed necessary, the Society may require buckling analysis based on criteria defined in Sec 5, [4.2] for metallic structure and Sec 5, [4.3] for composite structure.

Table 1 : Resistance factor γ_R

Type of element used in the model		creeping-sensitive element	non creeping-sensitive element
Beam elements		1,90	1,30
Standard mesh shell elements		1,70	1,20
Fine mesh shell elements (1)	Elements adjacent to the weld	1,10	0,80
	Elements not adjacent to the weld	1,00	0,70

(1) In addition, the following requirements apply to fine mesh shell elements:

- When a mesh size lower than 50 x 50 mm is used, the average stress within an area equivalent to 50 x 50 mm² is to comply with the requirements for fine mesh analysis.
- The average stress within an area equivalent to the standard mesh size is to comply with the requirements for standard mesh analysis. When the structural arrangement is not compatible with the standard mesh definition as given in Sec 5, [2.1.3], this average stress criteria is to be verified within an area equivalent to the minimum extent of the refined area as defined in Sec 5, [2.1.3].

3.2.3 Scantling check for winches

The design of the winches and equivalent equipments is based on the brake capacity in service conditions.

The minimum brake capacity of the winch is to be at least equal to the values defined in Tab 2.

3.2.4 Scantling check for mast rotating systems

An attestation from the ring manufacturer fixing the maximum permissible values for overturning moment and vertical force in the design load scenario OP-SEA is to be submitted to the Society.

These values are not to be lower than those calculated according to calculation approach defined in Sec 5, [2] increased by 10%.

The connections of the slewing ring with the mast and the hull support is to be documented.

Table 2 : Minimum braking force

RP, in kN (1)	Minimum braking force, in kN (2)
$RP < 200$	$1,50 RP$
$200 \leq RP \leq 500$	$1,20 RP + 60$
$RP > 500$	$1,32 RP$

(1) Rated line pull, in kN, deduced from [2.1.1]
 (2) Minimum rated holding force, in kN, of the static brake system at the reeled layer for which the RP is specified.

4 Scantling check for ship hull interface accessories**4.1 General**

4.1.1 The interface components between operating rigging parts and ship hull structure are to fulfill the criteria defined in Article [3].

Local ship hull reinforcements are to be as defined in Sec 8.

Section 7 Drive Systems

1 General

1.1 Application

1.1.1 The present Section applies to drive systems of the wind propulsion system. It includes the drive unit with all the machinery and electrical equipment/systems used to operate, control and monitor the wind propulsion system.

Drive systems include the following types:

- electrical drive
- hydraulic drive.

1.1.2 The present Section applies to drive systems in accordance with the following:

- For ships assigned the notation **WINDPROPULSION**:
 - Drive systems playing an essential part in the safety and structural integrity of the wind propulsion system in the design load scenarii SB-SEA and SB-HAR defined in Sec 4, [3.1.1].
- For ships assigned the notation **WINDPROPULSION -OPR**:
 - Drive systems, considered for the notation **WINDPROPULSION**,
 - Drive systems playing an essential part in the sails trim and adjustments of the wind propulsion system in the design load scenario OP-SEA defined in Sec 4, [3.1.1].

This scope of application is summarized in Tab 1.

Table 1 : Drive systems classification scope

Class notation	Function of the drive system	
	Safety	Operational
WINDPROPULSION	X	
WINDPROPULSION -OPR	X	X

1.1.3 Wind propulsion system control includes the following modes:

- full automatic if any automation
- remote operated from navigation bridge
- locally hand-operated.

1.2 Applicable requirements

1.2.1 Drive systems are to comply with the applicable requirements according to Tab 2.

Table 2 : Applicable requirements for drive systems

Item	Rule Reference
Main principles	<ul style="list-style-type: none"> • Article [2]
Machinery	<ul style="list-style-type: none"> • Article [4] • NR467, Pt C, Ch 1
Electrical installations	<ul style="list-style-type: none"> • Article [3] • NR467, Pt C, Ch 2
Automation	<ul style="list-style-type: none"> • Article [5] • NR467, Pt C, Ch 3

2 Main design principles

2.1 General

2.1.1 Machinery essential for the control and safety of the wind propulsion system is to be provided with effective means for its operation and control.

2.1.2 Drive system is to be designed so that any damage to pump, motor, monitoring system, electrical or hydraulic fluid supply will not cause the wind propulsion system to be out of control and thus endanger the life of operators or of the personnel.

2.1.3 Fail-to-safety principle

Control, alarm and safety systems are to be based on the fail-to-safety principle.

2.1.4 Type approved products

The drive system and its components, as indicated in NR467, Part C, are to be of a type approved by the Society.

Case by case certification may also be accepted at the discretion of the Society, based on submission of adequate documentation and subject to the satisfactory outcome of any required tests.

2.1.5 Environmental conditions

The drive system is to be designed to operate satisfactorily in the environment in which it is located. The environmental conditions are given as follows;

- For machinery installations: see NR467, Pt C, Ch 1, Sec 1
- For electrical installations: see NR467, Pt C, Ch 2, Sec 2.

2.1.6 Essential services

Essential service means a service necessary for a ship to proceed at sea, be steered or manoeuvred, or undertake activities connected with its operation, and for the safety of life, as far as class is concerned.

Examples of equipment for essential services are given in Tab 3.

Table 3 : Examples of essential services

Description of service	WINDPROPULSION	WINDPROPULSION -OPR
Mast rotating system	(1)	X
Mast lashing system	X	X
Winches used for safety rigging parts	X	X
Winches used for operating rigging	(1)	X
Monitoring and safety devices/systems	X	X
Control system of wind propulsion system	(1)	X
Fire detection and alarm system	X	X
Emergency shut-down systems having an impact on essential services	X	X
Mast tilting system	(1)	X
Navigation lights, aids and signals	X	X
Main lighting system for those parts of the wind propulsion system normally accessible to and used by the personnel	X	X
Hydraulic pumps supplying the above equipment	(1)	X
Auxiliary services supplying the above equipment (lubricating oil pumps, cooling water pumps)	(1)	X
(1) When system is used as safety guard		

2.2 Power sources

2.2.1 Loss of any power source (hydraulic, pneumatic, electric) is to be triggered by a specific alarm.

2.2.2 In case of a total loss of the usual means of control, appropriate emergency facilities are to be provided in order to possibly secure all the sail equipment in a safe position.

Duplication of power supplies is required if a single failure may disable the wind propulsion system to return to a safe state.

3 Electrical installations

3.1 General

3.1.1 Hazardous areas

As far as practicable, electrical installations intended for the wind propulsion system should not be located in hazardous areas (defined in Sec 8, [7.1.2]).

Where due to the operational requirements, some electrical equipment is located in hazardous areas zone 1 or zone 2, it has to comply with the requirements for such equipment in hazardous areas, as defined in NR467, Pt C, Ch 2, Sec 1.

3.1.2 Degrees of protection

Electric motors, equipment and cables are to be duly protected against:

- overcurrent
- ingress of liquids, depending on their location
- ingress of solid foreign bodies, depending on their intended use
- moisture and corrosion in sea water atmosphere
- accidental shocks, depending their on location.

The index of protection against ingress of liquids and solid bodies of electrical equipment, in relation to their location is generally that specified in NR467, Pt C, Ch 2, Sec 3, Tab 2.

4 Machinery

4.1 General

4.1.1 Safety devices on moving parts

Suitable access restrictions are to be provided in way of moving parts in order to avoid accidental contact of personnel with moving parts.

4.2 Hydraulic systems

4.2.1 Hydraulic installations are to comply with the applicable requirements of NR467, Pt C, Ch 1, Sec 10.

4.2.2 Hydraulic equipment are to be duly protected against

- overpressure
- oil pollution (abrasive particles)
- corrosion
- accidental shocks.

4.2.3 The design pressure of piping system is the pressure considered by the manufacturer to determine the scantling of the system components. It is not to be taken less than the maximum working pressure expected in this system or the highest setting pressure of any safety valve or relief device whichever is the greater.

Note 1: Maximum working pressure is to be determined according to loads defined in Sec 4 and load cases defined in Sec 4, Tab 2.

Special attention is to be paid on accidental case resulting in high transient working pressure so that the safety valve or relief device, is not reacting,

4.2.4 Scantlings of cylinder shell

The minimum thickness t of the steel cylindrical shell of luffing or slewing hydraulic cylinders is given, in mm, by the following formula:

$$t = pD / (2K - p)e$$

where:

- p : Design pressure, in MPa
 D : Inside diameter of the cylinder, in mm
 K : Permissible stress, in N/mm²

Where not otherwise specified, the permissible stresses K , may be taken as the minimum of the values obtained by the following formulae:

- $K = R_{m,20} / A$
- $K = R_s / B$

e : Efficiency of welded joint equal to 1 in general, specially considered by the Society depending on the service and the manufacture procedure.

A, B : Coefficients of utilisation defined in Tab 4.

$R_{m,20}$: Minimum tensile strength at ambient temperature (20°C), in N/mm²

R_s : Minimum between R_{eH} and $R_{p0.2}$ at the design temperature T , in N/mm^2 .

The thickness obtained is net thickness, as it does not include any corrosion allowance. The thickness obtained by the above formulae is to be increased by 0,75mm.

The Society reserves the right to increase the corrosion allowance value in the case of vessels exposed to particular accelerating corrosion conditions. The Society may also consider the reduction of this factor where particular measures are taken to effectively reduce the corrosion rate of the vessel.

Irrespective of the value calculated by the formulae, the thickness t is not to be less, in mm, than the following:

$$t = 3 + D/1500$$

No corrosion allowance needs to be added to the above value.

Note 1: The formula of t is applicable if the ratio external diameter/inside diameter is equal to or less than 1,5, if not the cylinder is subject to special consideration.

Table 4 : Coefficients of utilisation

	A	B
Steel	2,7	1,8
Steel castings	3,4	2,3
Nodular cast iron	4,5	3,5

4.2.5 Scantlings of cylinder heads

The thickness of the bottom and of the head of the cylinder is to comply with the applicable requirements of NR467, Pt C, Ch 1, Sec 3, [2.7].

4.2.6 Scantlings of piston rods

Scantlings of piston rods are to be checked for buckling according to the following strength criterion:

$$\omega \sigma_c \leq 0,55 R_e$$

where:

ω : Buckling coefficient determined with the following formula:

- $\omega = 1$ where $\lambda < 30 (235/R_e)^{1/2}$
- $\omega = B + \sqrt{B^2 - A}$ otherwise

where:

$$A = 112,8 \times 10^{-6} \lambda^2 R_e / 235$$

$$B = 0,5(A + 1) + \zeta(\sqrt{A} - 0,2)$$

σ_c : Compression stress, in N/mm^2

R_e : Yield stress, in N/mm^2 , considered in calculations of cylinder rod resistance.

λ : Slenderness ratio equal to the following value:

$$\lambda = 100 \ell \sqrt{\frac{S}{I}}$$

ℓ : Effective length of buckling equal to twice the maximum reach of cylinder rod

S : Cross sectional area, in cm^2

I : Moment of inertia, in cm^4 , of the considered cross-section

ζ : Coefficient equal to the following value:

- $\zeta = 0,1$ for closed cross-section beams (tubes, box beams, etc.)
- $\zeta = 0,17$ for open cross-section beams (lattice beams, angle bars, I, T or U-shape sections, etc.)

4.2.7 Testing pressure

a) Hydraulic cylinders

The hydraulic cylinders, the functions of which are the luffing, slewing or tilting of the boom, mast, balestron are to be submitted to an hydraulic test under a pressure at least equal to 1,5 times the design pressure.

b) Pumps

The pumps are to be submitted to a hydraulic test under the conditions as per NR467, Pt C, Ch 1, Sec 10, i.e. at a test pressure P_H , in MPa, equal to the following value:

- $P_H = 1,5 P$ when $P \leq 4$
- $P_H = 1,4 P + 0,4$ when $4 < P \leq 25$
- $P_H = P + 10,4$ when $P > 25$

where P is the design pressure, in MPa.

4.2.8 Pressure pipes are to satisfy the applicable requirements of NR467, Pt C, Ch 1, Sec 10. Flexible pipes are to be of approved type as per requirements of NR467 Pt C, Ch 1, Sec 10.

4.3 Pneumatic equipment

4.3.1 Design is to be established on the same basis as hydraulic equipment.

4.3.2 It is to be demonstrated that level of safety is not less than that which would be achieved by hydraulic equipment ensuring same functions and performances.

5 Automation

5.1 General

5.1.1 When automatically controlled, the system is not to increase significantly the bridge operator tasks.

5.1.2 Operating modes selection

The operating mode selection is to be made from the navigating bridge.

5.1.3 Failure behaviour

The automation system is to have non-critical behaviour in the event of power supply failure, faults or restoration of operating condition following a fault. If a redundant power supply is used, it must be taken from an independent source.

5.1.4 Failure alarm

Failure of automation systems is to generate an alarm.

Detailed indication, alarm and safety requirements regarding automation systems for individual machinery and installations are to be found in tables located in:

- NR467, Part C, Chapter 1, and
- NR467, Part F, Chapter 3 (for ships assigned a notation **AUT**).

5.1.5 Power supply

The conditions of power supply to be considered are defined in NR467, Pt C, Ch 3, Sec 1, [3.2].

5.2 Remote control

5.2.1 Failure of the remote control system is to activate an alarm.

Automatic fail-to-safety provisions may be required, depending on the risk assessment.

This automatic arrangement may be combined with the automatic release provided to avoid wind overloads on the wind propulsion systems (see Sec 4, Tab 2, note 5)

The case of wind assistance during the manoeuvre will specially be considered.

5.2.2 Wind propulsion system orders from the navigation bridge are to be indicated in the main machinery control room, and at the manoeuvring platform.

Indicators are to be fitted for:

- wind propulsion system inclination indicator, when relevant (e.g. tilt up mast)
- wind speed indicator
- alarm system with clear text indicating the failure of:
 - general failure of the control system
 - failure in the power system
 - failure of the stability system.

5.2.3 The control is to be performed by a single control device for each independent wind propulsion system, with automatic performance of all associated services, including, where necessary, means of preventing overload of the propulsion machinery.

Where multiple wind propulsion system are designed to operate simultaneously, they are to be controlled by one control device.

5.2.4 The wind propulsion system is to be provided with an emergency stopping device on the navigation bridge which is to be independent of the navigation bridge control system.

In the event that there is no reaction to an order to stop, provision is to be made for an alternative emergency stop. This emergency stopping device may consist of a simple and clearly marked control device, for example a push-button. This fitting is to be capable of putting the wind propulsion system in the less wind resistant position or sail furling, whatever the cause of the failure may be.

5.3 Alarm system

5.3.1 General

Alarm systems are to meet the requirements given in NR467, Pt C, Ch 3, Sec 2, [7].

Some non-restrictive recommendations are given in Tab 5.

Table 5 : Monitoring - Alarms

	Parameters	Alarms	Others
Sails	Automatic safety furling, folding or equivalent action	X	
	Overload	X	
Hydraulics	Oil tank level	Low	
	Oil pressure	Low	Auto start of stand-by pump
		Very low	
Oil temperature	High		
Pneumatics	Air pressure	Low	
Electrical equipment	General supply voltage	Low	
	Instrumentation supply voltage (sensors, alarms, computers)	Low	
	Instrumentation supply insulation	Low	
	Tripping of any computer watch dog	X	

5.4 Safety systems

5.4.1 The safety systems are intended to protect the wind propulsion system and the base ship against either casual or exceptional overload due to environmental conditions.

They include devices such as circuit breakers, safety valves, sail furling equipment, etc.

Automatic release systems provided to avoid wind overloads on the wind propulsion systems (see Sec 4, Tab 2, Note 5) are to be considered as safety systems.

5.4.2 Safety devices or systems are to operate separately from the control and alarm systems. Their operation is to give a suitable alarm.

5.4.3 Safety system failures

A safety system is to be designed so as to limit the consequence of failures. It is to be constructed on the fail-to-safety principle. The safety system is to be of the self-check type; as a rule, failure within the safety system, including the outside connection, is to activate an alarm.

5.4.4 Safety system activation

The safety system is to be activated in the event of identified conditions which could lead to damage of associated machinery, system or structural part such that:

- normal operating conditions are restored (e.g. by the starting of the standby unit), or
- the operation of the wind propulsion system is temporarily adjusted to avoid overloading (e.g. by reducing the tension in the sail sheets or kite tension line), or
- the wind propulsion system is protected, as far as possible, from critical conditions by arranging the wind propulsion system is an appropriate configuration that it induces wind forces as small as possible on structures (e.g. by furling the soft sails, stopping flettner rotors, folding or trimming the wind sails in such a way the combination lift/drag is as small as possible).

5.4.5 Safety system monitoring

When the safety system has been activated, it is to be possible to trace the cause of the safety action. This is to be accomplished by means of a central or local indication.

When a safety system is made inoperative by a manual override, this is to be clearly indicated at corresponding control stations.

Automatic safety actions are to activate an alarm at predefined control stations.

5.4.6 Shutdown

For shutdown systems of machinery, when the system has stopped a machine, the latter is not to be restarted automatically before a manual reset of the safety system has been carried out.

5.4.7 Testing

The safety systems are to be tested in accordance with the requirements in NR467, Pt C, Ch 3, Sec 6.

5.5 Interconnection and relationship with the mechanical propulsion plant

5.5.1 Time delayed alarm

When an automatic power load sharing “sails - main engine” is in service, a time delayed alarm given to the navigation bridge, is to be provided in case the engine operating load remains too low during an excessive period of time. Alternatively, similar arrangements may be provided by the application software.

5.5.2 Overload alarm

Where a possibility to cancel the automatic co-ordination sails - engine(s) exists, a dedicated overload alarm of the engines is to be provided.

5.5.3 Manoeuvre

In case of “crash stop” manoeuvre, it may be required, according to the ship and sail type, that optimal sail control be automatically achieved.

Section 8 Base Ship Requirements

1 Application

1.1 General

1.1.1 When a wind propulsion system is fitted on board, the requirements applicable to the ship are defined in the present Section.

1.1.2 The requirements of the present Section cover the:

- general arrangement
- stability
- hull structural assessment
- hull outfitting
- fire safety
- electrical installations.

2 General arrangement

2.1 General

2.1.1 Location of wind propulsion system

Wind propulsion system is to be so located and protected as to reduce to a minimum any danger to personnel, due regard being paid to moving parts or other hazards. Adequate provisions are to be made to facilitate cleaning, inspection and maintenance.

Note 1: Attention is to be paid to the following:

- SOLAS Ch.V Reg.22, where applicable, for visibility from the wheelhouse
- COLREG 1972 for the navigation lights
- any additional flag Administration specific requirements.

2.1.2 Configuration of wind propulsion system

When the wind propulsion system is in stand-by mode, it is to be possible to secure it and its configuration is to be so arranged that it induces wind forces as small as possible on structures.

3 Stability

3.1 General

3.1.1 This article specifies the stability criteria which are to be complied with when considering unfavourable effects resulting from the wind actions on the wind propulsion system.

The Society approves the intact stability files and, when applicable, the damage stability ones, according to the type of wind propulsion system and service notation of the ship, taking into consideration the criteria defined by the Society and subject to acceptance by the Flag Administration.

The Society may accept stability approvals and checking made by the Flag Administration or any Organisation duly recognized by the latter. In such a case, the documents which demonstrate that checking and approvals have been made are to be submitted to the Society.

Note 1: For multihulls and ships assigned the service notation **yacht** or **charter yacht**, different criteria may be applied on a case-by-case basis.

3.1.2 Icing

For any ship operating in areas where ice accretion is likely to occur, effect of icing-up of all or parts of the wind propulsion system on ship stability is to be examined according to NR467, Pt B, Ch 3, Sec 2, [6].

An inventory list of elements of the wind propulsion system where ice accretion is likely to occur is to be submitted to the Society for information.

3.2 Intact stability

3.2.1 The intact stability criteria specified in [3.2.3] or [3.2.4] as applicable depending on the configuration of the wind propulsion system as defined in [3.2.2], are to be complied with for the loading conditions mentioned in NR467, Pt B, Ch 3, App 2, [1.2]. However, the lightship condition not being an operational loading case, the Society may accept that part of the above-mentioned criteria are not fulfilled.

3.2.2 Wind propulsion system configurations

The different wind propulsion system configurations which provide unfavourable effects resulting from wind actions are to be considered.

At least the following configurations are to be investigated, when applicable:

- Wind propulsion system in stand-by mode and in a secured stowed position
- Wind propulsion system in operation with the following magnitude of operation:
 - full operation
 - intermediate operation
 - reduced operation.

Critical configurations as required by the risk analysis are to be evaluated.

3.2.3 Wind propulsion system in stand-by mode

The ability of a ship to withstand the combined effects of beam wind and rolling, with the wind propulsion system in stand-by mode, is to comply with NR467, Pt B, Ch 3, Sec 2, [1] to [5] for the loading conditions specified in [3.2.1].

Alternatively, and upon specific agreement with the Administration, the steady wind heeling lever ℓ_{w1} defined in NR467, Pt B, Ch 3, Sec 2, [3] may be taken as follows, with reference to Fig 1 and Fig 2:

- a) ℓ_{w1} may be taken equal to:
- For ships less than 500 GT:

$$\ell_{w1} = \frac{\sum_{i,j} F_{i,j} z_{i,j}}{1000g\Delta} \cos^{1,3} \theta$$

- For other ships:

$$\ell_{w1} = \frac{\sum_{i,j} F_{i,j} z_{i,j}}{1000g\Delta}$$

where:

$$F_{i,j} = 0,5\rho V^2 C_{si} C_{Hi,j} A_{i,j}$$

g : Gravity acceleration, equal to 9,81 m/s²

Δ : Displacement in t

θ : Angle of heel, in degrees

C_{si} : Coefficient depending on the shape of the ith member exposed to the wind (see Tab 1)

A_{i,j} : Projected lateral area of the ith exposed surface element, at the jth height stripes, in m²

C_{Hi,j} : Coefficient depending on the height above sea level of the A_{i,j} lateral area exposed to wind, at the jth height stripes (see Tab 2)

z_{i,j} : Vertical distance in m, from the centre of A_{i,j} to the centre of the underwater lateral area or approximately to a point at one half the draught

ρ : Air mass density, equal to 1,222 kg/m³

V : Wind speed, equal to 26 m/s.

- b) Alternative means for determining the wind heeling lever (ℓ_{w1}) may be accepted. When such alternative tests are carried out, reference is to be based on the Interim Guidelines for alternative assessment of the weather criterion (IMO MSC.1/Circ.1200). The wind velocity used in the tests is to be 26 m/s in full scale with uniform velocity profile. The value of wind velocity used for ships in restricted services may be reduced to the satisfaction of the Society.

These alternative tests may be completed by computational fluid dynamics models. In such a case, documentation specifying the methodology used and the procedures applied for the validation of models are to be submitted to the Society for review. Other documentation may be required on a case-by-case basis.

Figure 1 : Righting lever curve for wind propulsion system in stand-by mode for ship less than 500GT

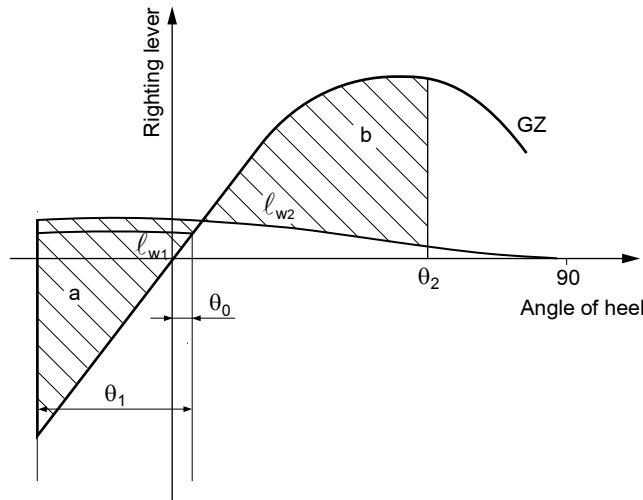

Note 1: a, b, l_{w2} , θ_0 , θ_1 and θ_2 are defined in NR467, Pt B, Ch 3, Sec 2, [3].

Figure 2 : Righting lever curve for wind propulsion system in stand-by mode for ship more than 500GT

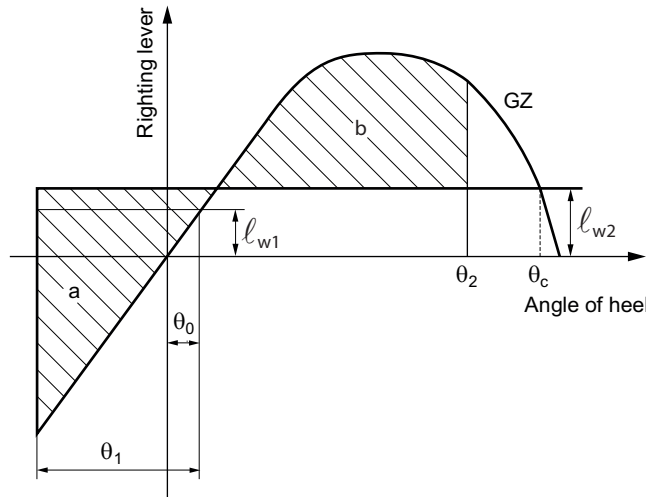

Note 1: a, b, l_{w2} , θ_0 , θ_1 and θ_2 are defined in NR467, Pt B, Ch 3, Sec 2, [3].

Table 1 : Values of the coefficient C_{Si}

Shape of each i^{th} member exposed to the wind	C_{Si}
Cylindrical	0,50
Round stranded wires	1,20
Note 1: Without specific available data, this coefficient is to be taken equal to 1,1.	
Note 2: Other shape coefficients may be considered on a case-by-case basis.	

Table 2 : Values of the coefficient $C_{Hi,j}$

Height above sea level of each j^{th} stripe (m)	$C_{Hi,j}$
0 - 15,3	1,00
15,3 - 30,5	1,10
30,5 - 46,0	1,20
46,0 - 61,0	1,30
61,0 - 76,0	1,37
76,0 - 91,5	1,43
91,5 - 106,5	1,48
106,5 - 122,0	1,52

3.2.4 Wind propulsion system in operation

The ability of a ship to withstand the combined effects of beam wind and rolling with the wind propulsion system in operation is to comply with the following criteria for the loading conditions specified in [3.2.1]:

- a) The angle of the static heel ϕ_{e1} due to the wind heeling lever is to be limited to the angle of heel corresponding to 90% of the immersion of the deck, or 20°, whichever is less
- b) The area “c” above the wind heeling lever and below the GZ curve, between the angle of static wind heel and the downflooding angle, is to be at least equal to 0,065 m.rad, with reference to Fig 3
- c) The metacentric height corrected by the free surface effects, is to be greater than or equal to 0,30 m.

The wind heeling lever used to assess the compliance with the criteria in a) and b) is to be calculated as follows:

$$\lambda = \frac{Fz}{1000g\Delta} \cos^{1.3} \theta$$

Where:

F : To be taken as defined in [3.2.3], item a), with V being the maximum wind speed including gusts, in m/s, for which the ship operates. This value may be different for each specific configuration of wind propulsions system in operation defined in [3.2.2].

z, g, Δ and θ: as defined in [3.2.3], item a).

Additional heeling lever resulting from the lift force acting on the wind propulsion system is to be considered. This value is to be specified by the Designer.

Figure 3 : Righting lever curve for wind propulsion system in operation

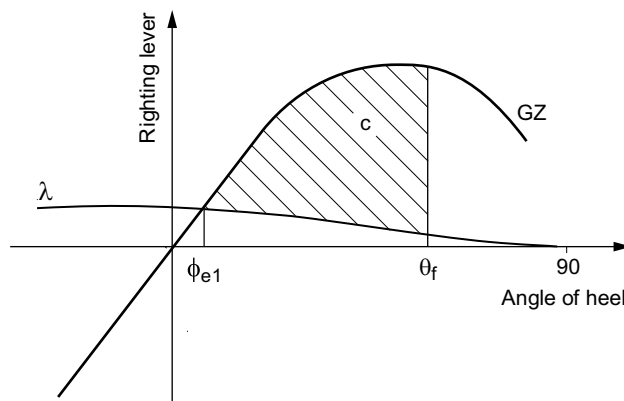

3.3 Counter-heeling systems

3.3.1 The stability of a ship sailing with counter-heeling system is to be assessed against the sudden loss of heeling moment due to the wind propulsion system.

3.3.2 The area on the leeward side of the ship (Area A₂) is to be greater than the residual area on the windward side of the ship (Area A₁), as shown in Fig 4, according to the following criterion:

$$A_2 > 1,4 A_1$$

where

GZ : Net righting lever curve accounting for the heeling moment due to the wind propulsion system and for the righting moment provided by the counter-heeling system

φ_{e1} : Angle of static heel due to the wind heeling lever

φ_{e2} : Angle of static equilibrium after loss of heeling moment due to the wind propulsion system

φ_f : Angle of down-flooding or the heel angle corresponding to the second intersection between heeling and righting arm curves, whichever is less.

The term “net righting lever” means that the calculation of the GZ curve includes the ship's true transverse centre of gravity as function of the angle of heel.

Note 1: When, after the loss of the lifted load, the ship still heels to the side of the lift, there is no need to comply with the above criterion.

Figure 4 : Righting lever curve after sudden loss of the heeling moment due to the wind propulsion system

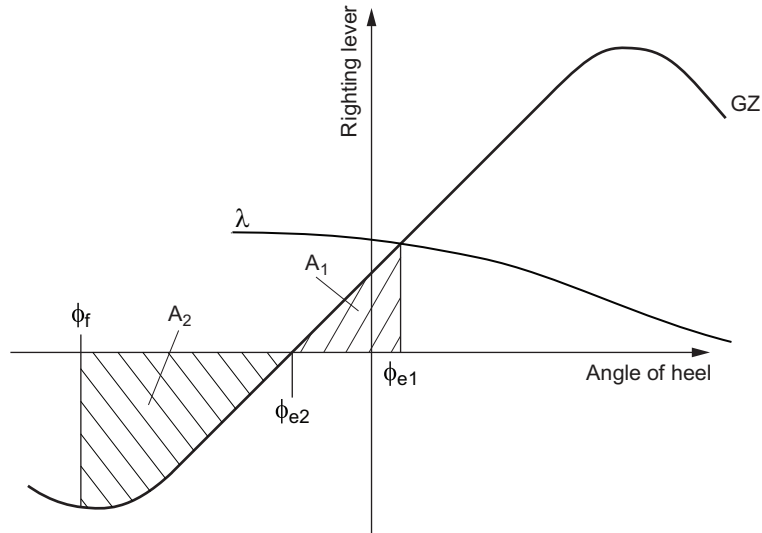

4 Structural strength

4.1 General

4.1.1 The ship foundation structure elements in way of the safety and operating rigging parts are to be designed taking into account the reaction forces and moments induced by the wind propulsion system according to the present Article.

4.1.2 The strength of the supporting hull structure is to be assessed in way of the hull areas defined in Sec 1, [2.3]

4.2 Design principles

4.2.1 The supporting hull structure is to be so arranged and designed to distribute uniformly, as far as practicable, the loads from the wind propulsion system foundation to the ship structure, in particular by maintaining a structural strength continuity between the various strength members.

4.3 Design loads

4.3.1 The design loads to be considered are the overall design loads defined in Sec 4, [5] increased by an additional safety factor of 1,15.

4.4 Local ship hull reinforcement

4.4.1 Ship hull reinforcement in way of safety and operating rigging parts

Ship hull reinforcement in way of safety and operating rigging parts is to comply with the requirements of NR467, NR600 or NR500, as applicable, taking into account design loads defined in [4.3.1].

4.4.2 Special considerations

- When the local ship hull structure in way of the wind propulsion system foundation contributes to the hull girder strength, the normal stresses in the hull girder induced by still and wave global bending moments and, when applicable, induced by the wind propulsion system arrangement in operation, are to be combined with the local stresses for the local reinforcement structure check.
- When deemed necessary to the Society, a fatigue analysis of the local hull structure in way of hull reinforcement may be carried out on a case by case basis.
- Ships fitted with a wind propulsion system and having specific hull shape may be subject to bottom slamming. In this case, local bottom reinforcement are to be considered on a case by case basis in the area where bottom slamming may occur.
- Buckling of deck in way of wind propulsion system is to be properly assessed.

4.5 Strength check of the global hull girder

4.5.1 General

When the wind propulsion system arrangement induces significant global hull girder bending moments and shear forces, these moments and forces are to be combined with the still and wave global hull girder loads to carry out the strength check of the hull girder structure.

The values of the global bending moments and shear forces induced by the wind propulsion system arrangement in operation are to be defined by the Designer. These values may be calculated on the basis of the moments and forces deduced from the structural model defined in Sec 5 reduced by 30%.

The strength check of the hull girder structure is to be carried out as defined in NR467 or NR600 as applicable.

5 Hull outfitting

5.1 Rudder

5.1.1 Strength and performance

The main steering gear and rudder stock are to be of adequate strength and capable of steering the ship in the different operating conditions of the wind propulsion system.

5.1.2 Rudder scantling

The rudder scantling is to be as defined in NR467, Pt B, Ch 12, Sec 1.

The rudder force C_R is to take into account the reaction force induced by the moment generated by the transverse forces from wind propulsion system and anti-drift forces. This reaction force is to be defined by the Designer.

5.2 Keel and leeboard

5.2.1 For keels and leeboards provided for ship stability purposes, the structure and hull reinforcements are to be examined on a case-by-case basis.

The weight of the keel or leeboard, the maximum ship heeling angles and the hydrodynamic anti-drift forces on keel or leeboard are to be submitted by the Designer.

The structure is to be checked taking into account a Von Mises equivalent stress σ_{eq} in compliance with the following formula:

$$\sigma_{eq} \leq \frac{R_y}{\gamma_m \gamma_R}$$

where:

R_y : Minimum yield stress, in N/mm², as defined in Sec 3

γ_m : Material factor to be taken equal to 1,02

γ_R : Resistance factor to be taken equal to:

- 1,9 for direct calculation
- 1,65 for finite element calculation in standard mesh areas and 1,5 in fine mesh areas.

The buckling acceptance criteria is to be as defined in Sec 5, [4.2.1], item b).

For keel structure and hull built in composite material, the main stresses and the combined stresses are to comply the criteria defined in Sec 5, [4.3.1], Sec 5, [4.3.2] and Sec 5, [4.3.3] respectively with SF and SF_{CS} increased by 40%.

5.2.2 For keels and leeboards provided for anti drift purposes only, the structure and hull reinforcements are to be examined as defined in [5.2.1]. The resistance factors and the buckling acceptance criteria are to be reduced by 20%.

5.2.3 The requirements in [5.2.1] and [5.2.2] are not applicable to bilge keels, which arrangement, scantlings and connection with bilge plating are to comply with the requirements given in NR467 or NR600, as applicable.

5.3 Equipment for anchoring and mooring

5.3.1 General

The equipment for anchoring and mooring of the ship is to be determined taking into account the calculation approach defined in NR467, NR500 or NR600, as applicable, with the wind propulsion system in the position defined in the operating manual for anchoring and mooring operations (mast tilted at horizontal position if applicable).

In addition, the forces due to the wind on the rigging are to be considered as follows:

a) For ships for which NR600 applies:

On the basis of the dynamic force F_{EN} in kN calculated as defined in NR600 increased by $1,5F_m$, where F_m is the static force defined in [5.3.2].

b) For ships for which NR500 applies:

On the basis of the dynamic force F_{EN} in kN calculated as defined in NR500 increased by $1,5F_m$ where F_m is the static force defined in NR500.

c) For others ships:

On the basis of the equipment number EN calculated as defined in NR467 increased by the following value EN_m :

$$EN_m = 7F_m$$

where F_m is the static force defined in [5.3.2].

5.3.2 Force on rigging

The theoretical static force induced by wind applied on the rigging, in kN, is defined according the following formula for each mast:

$$F_m = \frac{1}{2} \rho (C_{xm} h_m b_m + \sum C_{xi} \ell_i d_i 10^{-3} + 0,8 \sum S_{bfr_i} + 0,08 \sum S_{blat_i}) V^2 10^{-3}$$

where:

- ρ : Air density, equal to 1,22 kg/m³
- V : Speed of the wind, in m/s, as defined in NR467 or NR600, as applicable
- C_{xm} : Mast or rotor sail drag coefficient to be taken equal to:
 - 0,5 for cylindrical mast or rotor
 - 0,22 for streamlined mast or wing mast.

Note 1: Other drag coefficient may be taken into account if duly justified.

- h_m : Height, in m, of the mast or rotor
- b_m : Breadth, in m, of the mast or rotor
- C_{xi} : Shroud or furled sails drag coefficient to be taken equal to 1,2
- ℓ_i : Length, in m, of mast shrouds (lower and upper, fore and backstay) or furled sails
- d_i : Diameter, in mm, of shrouds or furled sails
- S_{bfr_i} : Front surface of i horizontal spar element (boom, balestron or other horizontal longitudinal element), in m², projected on a vertical plane perpendicular to the longitudinal axis of the ship

Note 2: when an horizontal spar element is situated behind a mast, S_{bfr_i} may be taken equal to 0.

- S_{blat_i} : Partial lateral surface of one single side of i horizontal spar element (boom, balestron or other horizontal longitudinal element), in m², projected on a vertical plane parallel to the longitudinal axis of the ship and situated aft of a distance equal to $4h_{bi}$ from the most forward part of the i element. When $\ell_{bsi} \leq 4h_{bi}$, S_{blat_i} is to be taken equal to 0
- h_{bi} : Height of the i horizontal spar element (boom, balestron or other horizontal longitudinal element), in m
- ℓ_{bsi} : Overall length of the i horizontal spar element (boom, balestron or other horizontal longitudinal element), in m.

For ship having several masts or rotors, the total static force induced by wind applied on the rigging is to be taken equal to the sum of the forces F_m of each mast or rotors.

Note 3: Mast, rotor sail or other system, tilted in horizontal position for anchoring and mooring operations, are to be considered as horizontal spar elements.

6 Fire safety

6.1 General

6.1.1 When required by risk analysis outputs, exposed surfaces are not to give rise to smoke or toxic or explosive hazards at elevated temperatures, this being determined in accordance with IMO Fire Test Procedures Code.

6.1.2 Machinery spaces containing the drive unit of the wind propulsion system are to comply with fire protection, detection and extinction requirements given in NR467, Pt C, Ch 4, considering these machinery spaces as other machinery spaces. Depending on the outputs of risk analysis or if deemed necessary by the Society, additional requirements may be considered on a case by case basis.

7 Electrical installation

7.1 General

7.1.1 Power supply

When the ship main power plant is used to supply the wind propulsion system, it is to have sufficient power to run simultaneously:

- the wind propulsion system at its maximum rated load
- the essential services (as defined in Sec 7, [2.1.6])
- the ballast system, when relevant.

7.1.2 Hazardous area

Electric and wiring are not to be installed in a hazardous area unless essential for operational purposes or safety enhancement, they are of certified safe type for use in the area.

Note 1: Hazardous area as defined in NR467, Pt C, Ch 2, Sec1 means an area in which an explosive gas atmosphere is or may be expected to be present, in quantities such as to require special precautions for the construction, installation and use of electrical apparatus.

7.2 Lightning protection and earth protection

7.2.1 Earthing definition

Electrical connections between conductive parts and local earth (in this case, the local earth, ship's hull, or metallic structure) in such a manner as to ensure an immediate discharge of electrical energy without danger at all times.

7.2.2 A protective system is to be fitted to the structure of non metallic construction or having a substantial number of non-metallic members. The lightning and earthing system is to be designed in accordance with the requirements of IEC 60092-401.

Section 9 Sea Trials, Initial Inspection and Testing

1 General

1.1 Application

1.1.1 This Section covers shipboard tests, both at the quay and during sea trials.

Note 1: Reference is made to Sec 3, [5] and App 1 for materials and components used in the construction of wind propulsion systems to be inspected and tested in relation to their use at the manufacturer's works.

1.1.2 Shipboard tests are intended to demonstrate that the wind propulsion system is functioning properly.

1.1.3 A list of the shipboard tests intended to be carried out is to be submitted to the Society by the wind propulsion system supplier.

For each test, the following information is to be provided:

- scope of the test
- acceptable wind speed range, when applicable
- relevant ship speed range, when applicable
- parameters to be recorded.

1.1.4 The tests are to be witnessed by a Surveyor.

The final test results and reports are to be submitted to the Society for examination.

2 Tests after fitting

2.1 General

2.1.1 After fitting, the wind propulsion system installations are submitted to the tests considered as necessary to check the good operational conditions.

Such tests are carried out at quay, when possible, or, if not, at sea.

2.1.2 A detailed programme of tests is to be approved by the Society. It is to include, in particular, the following tests:

- dielectric and insulation tests of the electric circuits
- test of each alarm channel
- test of any safety device, such as safety valves, automatic furling equipment limit switches
- test of the various modes of automatic use
- test of the last emergency control
- test of behaviour in case of black out
- test of automatic restarting for ships assigned a notation **AUT**
- test emergency operation of the system
- pretensioning check of safety rigging parts including rig tension, mastjack load or major bolts loads, if applicable.

2.1.3 Tests of piping system

Except otherwise permitted by the Society, all piping systems are to be leak tested under operational conditions after completion on board.

3 Sea trials

3.1 General

3.1.1 Global demonstrative trial is to be carried out at sea according to an approved programme to check that the wind propulsion system is satisfactory from the operation and control point of view.

3.1.2 Sea trial normally includes a period of navigation time under each of the navigation modes, including the emergency ones. The good working of the safeguards is also to be verified.

3.1.3 A demonstration of the behaviour of the ship under sails when a “black-out” occurs, and a “crash-stop” manoeuvre are also to be achieved, stopping distances and wind speed are to be noted for crew information purpose.

3.2 Functional tests

3.2.1 During sea trials, piping systems including associated monitoring and control devices, are to be subjected to functional tests at the nominal power of the machinery. Operating parameters (pressure, temperature, consumption) are to comply with the values recommended by the equipment manufacturer.

Section 10 Wind Propulsion Prepared Ships

1 General

1.1 Application

1.1.1 The additional class notation **WINDPROPULSION-PREPARED()** is assigned to new or existing ships that are designed to accommodate the future installation of a wind propulsion system, and complying with the requirements of this Section.

1.1.2 The additional class notation **WINDPROPULSION-PREPARED()** is to be associated to a well defined wind propulsion system that may be installed on the ship in the future. The wind propulsion system and its characteristics necessary for the assignment of the notation are to be indicated in a memorandum.

1.1.3 The additional class notation **WINDPROPULSION-PREPARED()** is to be completed, between brackets, by one or a combination of the following additional notations:

- **A** when the ship is arranged to accommodate the future installation of the wind propulsion system, in compliance with the requirements of Sec 8, [2]
- **S** when the stability of the ship is evaluated to take into account the future installation of the wind propulsion system, in compliance with the requirements of Sec 8, [3]
- **H** when the hull structure is designed to take into account the future installation of the wind propulsion system, in compliance with the requirements of Sec 8, [4]
- **O** when the hull outfitting for mooring and anchoring, rudder and steering gear are designed to take into account the future installation of the wind propulsion system, in compliance with the requirements of Sec 8, [5]
- **F** when the fire safety installations are designed to take into account the future installation of the wind propulsion system, in compliance with the requirements of Sec 8, [6].
- **E** when the electrical installations are designed to take into account the future installation of the wind propulsion system, in compliance with the requirements of Sec 8, [7].

1.2 Documentation to be submitted

1.2.1 The general documentation to be submitted for the additional class notation **WINDPROPULSION-PREPARED()** is listed in Tab 1.

The additional documentation to be submitted for the notations **S, H, O, F, E** is listed in:

- Tab 2 for the notation **S**
- Tab 3 for the notation **H**
- Tab 4 for the notation **O**
- Tab 5 for the notation **F**
- Tab 6 for the notation **E**.

Note 1: No additional documentation is to be submitted for the notation **A**.

1.2.2 The documentation listed in Tab 1 to Tab 5 is to take into account the effects of the future installation and operation of the wind propulsion system.

Table 1 : General documentation to be submitted

No.	A/I (1)	Documentation	Particulars
1	I	General arrangement of the ship	Showing the wind propulsion system and its characteristics
2	I	Risk assessment report	According to Sec 1, [1.4]
3	I	Operating manual	Including the operational design conditions and environmental limiting conditions (wind and sea state)
(1) A: to be submitted for approval; I: to be submitted for information.			

Table 2 : Additionnal documentation for the notation S

No.	A/I (1)	Documentation	Particulars
1	A	Preliminary stability booklet	
(1) A: to be submitted for approval; I: to be submitted for information.			

Table 3 : Additionnal documentation for the notation H

No.	A/I (1)	Documentation	Particulars
1	A	Local hull structure reinforcements in way of ship hull areas	<ul style="list-style-type: none"> Specifying the reaction loads induced by the safety and operating rigging parts (winch, clutch, sheet track rails, sheave supports) The ship hull areas are defined in Sec 1, [2.3]
2	A	Connections of the slewing ring with the hull supporting structure	In case of mast rotating systems
3	I	Global hull girder loads calculation	According to Sec 8, [4.5]
4	I	Fatigue analysis of the local hull structure	According to Sec 8, [4.4.2]
(1) A: to be submitted for approval; I: to be submitted for information.			

Table 4 : Additionnal documentation for the notation O

No.	A/I (1)	Documentation	Particulars
1	A	Equipment number calculation	
2	I	Calculation of the reaction force in way of the rudder	According to Sec 8, [5.1.2]
(1) A: to be submitted for approval; I: to be submitted for information.			

Table 5 : Additionnal documentation for the notation F

No.	A/I (1)	Documentation	Particulars
1	A	Fire protection, fire detection and fire fighting system, if any	As applicable to the machinery spaces containing the drive unit of the wind propulsion system
(1) A: to be submitted for approval; I: to be submitted for information.			

Table 6 : Additionnal documentation for the notation E

No.	A/I (1)	Documentation	Particulars
1	A	Ship hydraulic and electrical installations	As applicable, for installations intended to power the operating rigging system
2	I	Electrical load balance	
(1) A: to be submitted for approval; I: to be submitted for information.			

Appendix 1 Requirements for Survey of Materials and Equipment

1 Application

1.1 General

1.1.1 This Appendix gives the certification requirements for materials and equipment (generally referred as “products”) which are covered for classification purpose in the scope of the additional class notations **WINDPROPULSION** and **WINDPROPULSION -OPR** defined in Sec 1, [1.3.2].

The certification requirements for the various type of wind propulsion systems defined in Sec 1, [2.1] are given as follows:

- for rotor sails, see Tab 1
- for suction wing sails, see Tab 2
- for kite sails, see Tab 3
- for soft wing sails and rigid wing sails, see Tab 4
- for rig sails (modern rig, traditional rig, free standing rig, balestron rig and modern square rig), see Tab 5.

1.1.2 The requirements for materials and equipment used or fitted on board are given in the relevant parts of the present Rules or NR467, as applicable.

1.1.3 The certification scheme of materials and equipment is given in the Society’s Rule Note NR320 “Certification Scheme of Materials and Equipment for the Classification of Marine Units”.

1.1.4 The particular conditions and requirements expressed by Flag Administration, owners, shipyards or manufacturers may lead to additional surveys or other services to be specified and agreed in each case by the concerned parties.

1.2 Explanatory notes, symbols and abbreviations

1.2.1 Symbols used in Tab 1 to Tab 5 have the following meaning:

- C : BV product certificate is required with invitation of the Surveyor to attend the tests, unless otherwise agreed, in addition to the manufacturer’s document stating the results of the tests performed and/or compliance with the approved type (as applicable).
- W : Manufacturer’s document is required, stating the results of the tests performed and/or stating compliance with the approved type (as applicable).
- X : Examinations and tests are required.
- Where fitted, each additional index (h, ndt) indicates a specific type of test:
- h : Hydraulic pressure test (or equivalent)
- ndt : Non destructive tests as per Rules.

1.2.2 Column 1 (item name)

Column 1 contains the name of the equipment or component with, eventually, its sub-systems.

1.2.3 Column 2 (design assessment / approval index)

Column 2 contains the design assessment / approval index. The meaning of the letters TA and DA is the following:

- TA : Type Approval is required
- TA (HBV): Type Approval is required with work’s recognition (HBV scheme as per NR320)
- DA : Design assessment/Appraisal of the product is required; this one may be carried out as applicable:
- either for a specific unit, or
 - using the Type Approval procedure.

Where nothing is mentioned in column 3, a design assessment/approval of the specific unit is not required.

1.2.4 Column 3 (raw material certificate)

Column 3 indicates the nature of the document that is to be submitted by the manufacturer or supplier of the concerned raw material.

Note 1: Consistently with the Rules or agreed specifications, this document includes data such as material tests (chemical composition and mechanical properties), non-destructive tests and surface hardness (if hardened).

1.2.5 Columns 4 (examination and testing)

Column 4 indicates that examination and/or testing are required, and are to be carried out by the manufacturer. For the type of examination and/or testing required, reference is to be made to the relevant provisions of the present Rules.

As a general rule, even if a cross "X" is not fitted in a cell under column 5, examination and tests during fabrication may be required with invitation/attendance of the Society's Surveyor.

1.2.6 Column 5 (product certificate)

Column 5 indicates the nature of the document to be supplied by the manufacturer of the concerned product.

1.2.7 Column 6 (remarks)

Column 6 indicates the remarks (if any) associated to the concerned equipment or component.

1.3 Notice regarding columns 2 to 6 (product certification)

1.3.1 Column 2, column 3, column 4, column 5 and column 6 summarize the product certification process or steps to be completed by the manufacturer within the scope of Survey of Materials and Equipment at Works by the Society.

**Table 1 : Requirements for survey of materials and equipment -
Rotor sails for ships assigned with the additional class notations WINDPROPULSION or WINDPROPULSION -OPR**

Item	Product certification				Remarks
	Design assessment / Approval	Raw material certificate	Examination and testing	Product certificate	
Rotor sail - Wind propulsion system	DA/TA		X ndt	C (1)	(1) When the full assembly is completed by the manufacturer
Steel and aluminum (Raw materials)					
1 - Steel plates, profiles, bars for mast structure	(1)	C (1)		(3)	(1) Approval as per NR216 and NR480, as applicable (2) Type approval as per NR216 (3) See raw material certification
2 - Aluminum alloy plates, profiles, bars for mast structure	(1)	C (1)		(3)	
3 - Filler products for welding (welding consumables)	TA (2)			W	
4 - Aluminum alloy rivets for mast structure	(1)	C (1)		(3)	
5 - Transition joints steel / aluminum alloy	TA (1)	C		C	
6 - Steel castings/forgings	(1)	C (1)	X ndt	(3)	
7 - Aluminum alloy castings	(1)	C (1)	X ndt	(3)	
Laminate composite materials					
1 - Adhesives assembly	DA (5)		X (5)	C / W (3)	(1) see provisions of NR546 (2) Representative samples of the composite construction is to be tested and qualified as per agreed program; relevant tests to be carried out by a testing laboratory accepted by the Society (3) Document type according to the agreed survey scheme - as per conditions set in the DA (4) Mechanical tests according to Sec 3, [3.4.3] (5) See NR613, NR546 and Sec 5, [5.5] (6) An equivalent raw material homologation process may be applied according to NR546, App 1, [3]
2 - Reinforcement fibres	TA HBV (6)			W	
3 - Resin systems	TA HBV (6)			W	
4 - Core materials for sandwiches	TA HBV (6)			W	
5 - Adhesives	TA HBV (4)			W	
6 - Prepreg	TA HBV (6)			W	
7 - Test panel	DA (1)		X (2)		

Item	Product certification				Remarks
	Design assessment / Approval	Raw material certificate	Examination and testing	Product certificate	
Rotor sail - safety rigging parts (excluding drive unit)					(1) Approval as per the present Rule Note (2) The extent and the nature of the non-destructive examinations are subject to the Society's agreement. (3) According to type of materials (5) Tests as per Sec 3, [4.6] (6) For special bolts (i.e. expansion type), product certificate C is required. In other cases, ISO 898-1 :2013 certified bolts are to be considered as per section 3 [3.2] and a Work's certificate is required. Notes: Checking of fitting on board
1 - Mast	DA /TA (1)	(3)	X (2)	C	
2 - Wind propulsion system accessories	DA (1)	W	X (2) (5)	W	
3 - Coupling bolts	DA (1)	C/W (6)	X	C / W (6)	
4 - Bearings	DA	W	X (2)	W	
5 - Slewing ring	DA	C	Xndt	C	
6 - Pedestal (not permanently connected to the hull)	DA	C	Xndt	C	
Rotor sail - Operating rigging parts (excluding drive unit)					(1) Approval as per Sec 3, [4.6] (2) For welded construction. The extent and the nature of the non-destructive examinations are subject to the Society's agreement (3) Tests as per Sec 3, [4.6]
1 - Wind propulsion system accessories	DA (1)	W	X (2) (3)	W	
2 - Slewing ring	DA	C	Xndt	C	
Rotor sail - Drive unit - Mechanical system (safety or operating rigging parts)					(1) Electrical motors and equipment to be considered as intended 'for essential services'. Survey requirements as per NR266 item K (2) As per Society's agreement. (3) Diesel engines to be type approved as marine engines. Survey requirements as per NR266 item E1 and applicable provisions of NR467, Pt C, Ch 1, Sec 2
1 - Reduction gears with transmitted power ≥ 110 kW	DA / TA	W / C	X h ndt	C	
2 - Reduction gears with transmitted power < 110 kW	DA / TA	W	X	W	
3 - Motors and electrical equipment essential for the function of the winch (1)			X	C	
4 - Auxiliary machinery items essential for the function of the wind propulsion system	(2) (3)				
Rotor sail - Drive unit - Electrical system (safety or operating rigging parts)					(1) Electrical motors and equipment to be considered as intended 'for essential services'. Survey requirements as per NR266 item K (2) As per NR467, Pt C, Ch3 (3) As per condition set in TA
1 - Electric motors for essential functions of the wind propulsion system (1)	DA / TA		X	C / W	
2 - Cables, Circuit breakers, Contactors, Switch	TA			W / C (3)	
3 - Convertors	DA / TA			C	
4 - Switchboard	DA		X	C	
5 - Other electrical equipment (1)	DA	(1)	(1)	(1)	
6 - Control and monitoring system	DA / TA (2)		X	C / W (3)	

**Table 2 : Requirements for survey of materials and equipment -
Suction wind sails for ships assigned with the additional class notations WINDPROPULSION or WINDPROPULSION -OPR**

Item	Product certification				Remarks
	Design assessment / Approval	Raw material certificate	Examination and testing	Product certificate	
Suction wind sail - Wind Propulsion System	DA/TA		X ndt	C (1)	(1) When the full assembly is completed by the manufacturer
Steel and aluminum (Raw materials)					(1) Approval as per NR216 and NR480, as applicable (2) Type approval as per NR216 (3) See raw material certification
1 - Steel plates, profiles, bars for mast structure	(1)	C (1)		(3)	
2 - Aluminum alloy plates, profiles, bars for mast structure	(1)	C (1)		(3)	
3 - Filler products for welding (welding consumables)	TA (2)			W	
4 - Aluminum alloy rivets for mast structure	(1)	C (1)		(3)	
5 - Transition joints steel / aluminum alloy	TA (1)	C		C	
6 - Steel castings/forgings	(1)	C (1)	X ndt	(3)	
7 - Aluminum alloy castings	(1)	C (1)	X ndt	(3)	
Laminate composite materials					(1) see provisions of NR546 (2) Representative samples of the composite construction is to be tested and qualified as per agreed program; relevant tests to be carried out by a testing laboratory accepted by the Society (3) Document type according to the agreed survey scheme - as per conditions set in the DA (4) Mechanical tests according to Sec 3, [3.4.3] (5) See NR613, NR546 and Sec 5, [5.5] (6) An equivalent raw material homologation process may be applied according to NR546, App 1, [3]
1 - Adhesives assembly	DA (5)		X (5)	C / W (3)	
2 - Reinforcement fibres	TA HBV (6)			W	
3 - Resin systems	TA HBV (6)			W	
4 - Core materials for sandwiches	TA HBV (6)			W	
5 - Adhesives	TA HBV (4)			W	
6 - Prepreg	TA HBV (6)			W	
7 - Test panel	DA (1)		X (2)		

Item	Product certification				Remarks
	Design assessment / Approval	Raw material certificate	Examination and testing	Product certificate	
Suction wind sail - Safety rigging parts (excluding drive unit)					(1) Approval as per the present Rule Note (2) The extent and the nature of the non-destructive examinations are subject to the Society's agreement. (3) According to type of materials (4) Tests as per Sec 3, [4.6] (5) For special bolts (i.e. expansion type), product certificate C is required. In other cases, ISO 898-1 :2013 certified bolts are to be considered as per section 3 [3.2] and a Work's certificate is required. Notes: Checking of fitting on board
1 - Mast	DA /TA (1)	(3)	X (2)	C	
3 - Coupling bolts	DA (1)	C/W (5)	X	C / W (5)	
4 - Bearings	DA	W	X (2)	W	
5 - Slewing ring	DA	C	Xndt	C	
6 - Pedestal (not permanently connected to the hull)	DA	C	Xndt	C	
Suction wind sail - Operating rigging parts (excluding drive unit)					(1) Approval as per Sec 3, [4.6] (2) For welded construction. The extent and the nature of the non-destructive examinations are subject to the Society's agreement (3) Tests as per Sec 3, [4.6]
1 - Wind propulsion system accessories	DA (1)	W	X (2) (3)	W	
2 - Slewing ring	DA	C	Xndt	C	
Suction wind sail - Drive unit - Mechanical system (safety or operating rigging parts)					(1) Electrical motors and equipment to be considered as intended 'for essential services'. Survey requirements as per NR266 item K (2) As per Society's agreement. (3) Diesel engines to be type approved as marine engines. Survey requirements as per NR266 item E1 and applicable provisions of NR467, Pt C, Ch 1, Sec 2
1 - Reduction gears with transmitted power ≥110 kW	DA / TA	W / C	X h ndt	C	
2 - Reduction gears with transmitted power < 110 kW	DA / TA	W	X	W	
3 - Motors and electrical equipment essential for the function of the winch (1)			X	C	
4 - Auxiliary machinery items essential for the function of the wind propulsion system	(2) (3)				
Suction wind sail - Drive unit - Electrical system (safety or operating rigging parts)					(1) Electrical motors and equipment to be considered as intended 'for essential services'. Survey requirements as per NR266 item K (2) As per NR467, Pt C, Ch3 (3) As per condition set in TA
1 - Electric motors for essential functions of the wind propulsion system (1)	DA / TA		X	C / W	
2 - Cables, Circuit breakers, Contactors, Switch	TA			W / C (3)	
3 - Convertors	DA / TA			C	
4 - Switchboard	DA		X	C	
5 - Other electrical equipment (1)	DA	(1)	(1)	(1)	
6 - Control and monitoring system	DA / TA (2)		X	C / W (3)	

**Table 3 : Requirements for survey of materials and equipment -
Kite sails for ships assigned with the additional class notations WINDPROPULSION or WINDPROPULSION -OPR**

Item	Product certification				Remarks
	Design assessment / Approval	Raw material certificate	Examination and testing	Product certificate	
Kite Sail - Wind Propulsion System	DA/TA		X ndt	C (1)	(1) When the full assembly is completed by the manufacturer
Steel and aluminum (Raw materials)					(1) Approval as per NR216 and NR480, as applicable (2) Type approval as per NR216 (3) See raw material certification
1 - Steel plates, profiles, bars for mast structure	(1)	C (1)		(3)	
2 - Aluminum alloy plates, profiles, bars for mast structure	(1)	C (1)		(3)	
3 - Filler products for welding (welding consumables)	TA (2)			W	
4 - Aluminum alloy rivets for mast structure	(1)	C (1)		(3)	
5 - Transition joints steel / aluminum alloy	TA (1)	C		C	
6 - Steel castings/forgings	(1)	C (1)	X ndt	(3)	
7 - Aluminum alloy castings	(1)	C (1)	X ndt	(3)	
Laminate composite materials					(1) see provisions of NR546 (2) Representative samples of the composite construction is to be tested and qualified as per agreed program; relevant tests to be carried out by a testing laboratory accepted by the Society (3) Document type according to the agreed survey scheme - as per conditions set in the DA (4) Mechanical tests according to Sec 3, [3.4.3] (5) See NR613, NR546 and Sec 5, [5.5] (6) An equivalent raw material homologation process may be applied according to NR546, App 1, [3]
1 - Adhesives assembly	DA (5)		X (5)	C / W (3)	
2 - Reinforcement fibres	TA HBV (6)			W	
3 - Resin systems	TA HBV (6)			W	
4 - Core materials for sandwiches	TA HBV (6)			W	
5 - Adhesives	TA HBV (4)			W	
6 - Prepreg	TA HBV (6)			W	
7 - Test panel	DA (1)		X (2)		

Item	Product certification				Remarks
	Design assessment / Approval	Raw material certificate	Examination and testing	Product certificate	
Kite Sail - Safety rigging parts (excluding drive unit)					(1) Approval as per the present Rule Note (2) The extent and the nature of the non-destructive examinations are subject to the Society's agreement. (3) According to type of materials (4) Tests as per Sec 3, [4.6] (5) For special bolts (i.e. expansion type), product certificate C is required. In other cases, ISO 898-1 :2013 certified bolts are to be considered as per section 3 [3.2] and a Work's certificate is required. Notes: Checking of fitting on board
1 - Mast	DA /TA (1)	(3)	X (2)	C	
2 - Wind propulsion system accessories	DA (1)	W	X (2) (4)	W	
3 - Coupling bolts	DA (1)	C/W (5)	X	C / W (5)	
4 - Pedestal (not permanently connected to the hull)	DA	C	Xndt	C	
Kite Sail - Operating rigging parts (excluding drive unit)					(1) Approval as per Sec 3, [4.6] (2) Breaking test on specimen as per Sec 3, [4.6] (3) For welded construction. The extent and the nature of the non-destructive examinations are subject to the Society's agreement (4) Proof load as per Sec 3, [4.7]a) (5) Tests as per Sec 3, [4.3] (6) Tests as per Sec 3, [4.5] (7) Tests as per Sec 3, [4.6]
1 - Ropes intended for operating rigging parts - Steel and fiber ropes -Terminal accessories	DA (1)	W	X (2)	W	
2 - Deck eyeplates, chain plate for operating rigging parts	DA (1)	W	X (3) (4)	W	
3 - Sheaves	DA (1)	W	X (3) (6)	W	
4 - Wind propulsion system accessories	DA (1)	W	X (3) (7)	W	
5 - Winches and their accessories for operating rigging parts	DA (1)	W	X (5)	W	
Kite Sail - Drive unit - Mechanical system (safety or operating rigging parts)					(1) Approval as per the present Rule Note (2) Material as per NR216 (3)For welded construction. The extent and the nature of the non-destructive examinations are subject to the Society's agreement (4) Running test as per agreed program (5) Electrical motors and equipment to be considered as intended 'for essential services'. Survey requirements as per NR266 item K
1 - Winches for rotating and release systems	DA (1)	(2)	X (3) (4)	C	
2 - Motors and electrical equipment essential for the function of the winch (5)			X	C	
Kite Sail - Drive unit - Electrical system (safety or operating rigging parts)					(1) As per NR467, Pt C, Ch3 (2) As per condition set in TA
1 - Cables, Circuit breakers, Contactors, Switch	TA			W / C (2)	
2 - Switchboard	DA		X	C	
3 - Control and monitoring system	DA / TA (1)		X	C / W (2)	

**Table 4 : Requirements for survey of materials and equipment -
Wing sails for ships assigned with the additional class notations WINDPROPULSION or WINDPROPULSION -OPR**

Item	Product certification				Remarks
	Design assessment / Approval	Raw material certificate	Examination and testing	Product certificate	
Wing Sail - Wind Propulsion System	DATA		X ndt	C (1)	(1) When the full assembly is completed by the manufacturer
Steel and aluminum (Raw materials)					
1 - Steel plates, profiles, bars for mast structure	(1)	C (1)		(3)	(1) Approval as per NR216 and NR480, as applicable (2) Type approval as per NR216 (3) See raw material certification
2 - Aluminum alloy plates, profiles, bars for mast structure	(1)	C (1)		(3)	
3 - Filler products for welding (welding consumables)	TA (2)			W	
4 - Aluminum alloy rivets for mast structure	(1)	C (1)		(3)	
5 - Transition joints steel / aluminum alloy	TA (1)	C		C	
6 - Steel castings/forgings	(1)	C (1)	X ndt	(3)	
7 - Aluminum alloy castings	(1)	C (1)	X ndt	(3)	
Laminate composite materials					
1 - Adhesives assembly	DA (5)		X (5)	C / W (3)	(1) see provisions of NR546 (2) Representative samples of the composite construction is to be tested and qualified as per agreed program; relevant tests to be carried out by a testing laboratory accepted by the Society (3) Document type according to the agreed survey scheme - as per conditions set in the DA (4) Mechanical tests according to Sec 3, [3.4.3] (5) See NR613, NR546 and Sec 5, [5.5] (6) An equivalent raw material homologation process may be applied according to NR546, App 1, [3]
2 - Reinforcement fibres	TA HBV (6)			W	
3 - Resin systems	TA HBV (6)			W	
4 - Core materials for sandwiches	TA HBV (6)			W	
5 - Adhesives	TA HBV (4)			W	
6 - Prepreg	TA HBV (6)			W	
7 - Test panel	DA (1)		X (2)		

Item	Product certification				Remarks
	Design assessment / Approval	Raw material certificate	Examination and testing	Product certificate	
Wing Sail - Safety rigging parts (excluding drive unit)					(1) Approval as per the present Rule Note (2) The extent and the nature of the non-destructive examinations are subject to the Society's agreement. (3) According to type of materials (4) Proof load as per Sec 3, [4.7], item a) (5) Tests as per Sec 3, [4.6] (6) For special bolts (i.e. expansion type), product certificate C is required. In other cases, ISO 898-1 :2013 certified bolts are to be considered as per section 3 [3.2] and a Work's certificate is required. Notes: Checking of fitting on board
1 - Mast	DA /TA (1)	(3)	X (2)	C	
2 - Shrouds intended for safety rigging parts: - Steel and fiber ropes - Terminal accessories	DA (1)	W	X (2)	C	
3 - Deck eyeplates, chain plate for safety rigging parts	DA (1)	(1)	X (2) (4)	C	
4 - Wind propulsion system accessories	DA (1)	W	X (2) (5)	W	
5 - Coupling bolts	DA (1)	C/W (6)	X	C / W (6)	
6 - Bearings	DA	W	X (2)	W	
7 - Slewing ring	DA	C	Xndt	C	
8 - Pedestal (not permanently connected to the hull)	DA	C	Xndt	C	
Wing Sail - Operating rigging parts (excluding drive unit)					(1) Approval as per Sec 3, [4.6] (2) Breaking test on specimen as per Sec 3, [4.6] (3) For welded construction. The extent and the nature of the non-destructive examinations are subject to the Society's agreement (4) Proof load as per Sec 3, [4.7], item a) (5) Tests as per Sec 3, [4.3] (6) Tests as per Sec 3, [4.5] (7) Tests as per Sec 3, [4.6]
1 - Ropes intended for operating rigging parts - Steel and fiber ropes -Terminal accessories	DA (1)	W	X (2)	W	
2 - Deck eyeplates, chain plate for operating rigging parts	DA (1)	W	X (3) (4)	W	
3 - Sheaves	DA (1)	W	X (3) (6)	W	
4 - Wind propulsion system accessories	DA (1)	W	X (3) (7)	W	
5 - Winches and their accessories for operating rigging parts	DA (1)	W	X (5)	W	
6 - Slewing ring	DA	C	Xndt	C	
Wing Sail - Drive unit - Mechanical system (safety or operating rigging parts)					(1) Material certificate of small pumps or valve required depending on the type of wind propulsion system. (2) Same considerations as for Pumps. See NR467 Pt.C, Ch.1, Sec.10, tab 41 (material certificates according to the piping class)
1 - Hydraulic accumulator	DA / TA	W / C	X h ndt	W / C	
2 - Hydraulic cylinders class I	DA / TA	C	X h ndt	C	
3 - Hydraulic motors / pumps belonging to class I and II	DA / TA	W / C (2)	X h ndt	C	
4 - Hydraulic motors / pumps belonging to class III			X h	W	
5 - Flexible hoses	TA	W	X h	C	
6 - Piping system and fittings		W / C (1)	X h ndt	W / C	

Item	Product certification				Remarks
	Design assessment / Approval	Raw material certificate	Examination and testing	Product certificate	
Wing Sail - Drive unit - Electrical system (safety or operating rigging parts)					(1) Electrical motors and equipment to be considered as intended 'for essential services'. Survey requirements as per NR266 item K (2) As per NR467, Pt C, Ch3 (3) As per condition set in TA
1 - Electric motors for essential functions of the wind propulsion system (1)	DA / TA		X	C / W	
2 - Cables, Circuit breakers, Contactors, Switch	TA			W / C (3)	
3 - Switchboard	DA		X	C	
4 - Control and monitoring system	DA / TA (2)		X	C / W (3)	



**Table 5 : Requirements for survey of materials and equipment -
Rig sails for ships assigned with the additional class notations WINDPROPULSION or WINDPROPULSION -OPR**

Item	Product certification				Remarks
	Design assessment / Approval	Raw material certificate	Examination and testing	Product certificate	
Rig Sail (modern rig, traditional rig, free standing rig, baleson rig and modern square rig) - Wind Propulsion System	DA/TA		X ndt	C (1)	(1) When the full assembly is completed by the manufacturer
Steel and aluminum (Raw materials)					
1 - Steel plates, profiles, bars for mast structure	(1)	C (1)		(3)	(1) Approval as per NR216 and NR480, as applicable (2) Type approval as per NR216 (3) See raw material certification
2 - Aluminum alloy plates, profiles, bars for mast structure	(1)	C (1)		(3)	
3 - Filler products for welding (welding consumables)	TA (2)			W	
4 - Aluminum alloy rivets for mast structure	(1)	C (1)		(3)	
5 - Transition joints steel / aluminum alloy	TA (1)	C		C	
6 - Steel castings/forgings	(1)	C (1)	X ndt	(3)	
7 - Aluminum alloy castings	(1)	C (1)	X ndt	(3)	
Laminate composite materials					
1 - Adhesives assembly	DA (5)		X (5)	C / W (3)	(1) see provisions of NR546 (2) Representative samples of the composite construction is to be tested and qualified as per agreed program; relevant tests to be carried out by a testing laboratory accepted by the Society (3) Document type according to the agreed survey scheme - as per conditions set in the DA (4) Mechanical tests according to Sec 3, [3.4.3] (5) See NR613, NR546 and Sec 5, [5.5] (6) An equivalent raw material homologation process may be applied according to NR546, App 1, [3]
2 - Reinforcement fibres	TA HBV (6)			W	
3 - Resin systems	TA HBV (6)			W	
4 - Core materials for sandwiches	TA HBV (6)			W	
5 - Adhesives	TA HBV (4)			W	
6 - Prepreg	TA HBV (6)			W	
7 - Test panel	DA (1)		X (2)		

Item	Product certification				Remarks
	Design assessment / Approval	Raw material certificate	Examination and testing	Product certificate	
Rig Sail - Safety rigging parts (excluding drive unit)					(1) Approval as per the present Rule Note (2) The extent and the nature of the non-destructive examinations are subject to the Society's agreement. (3) According to type of materials (4) Proof load as per Sec 3, [4.7]a) (5) Tests as per Sec 3, [4.6] (6) For special bolts (i.e. expansion type), product certificate C is required. In other cases, ISO 898-1 :2013 certified bolts are to be considered as per section 3 [3.2] and a Work's certificate is required. Notes: Checking of fitting on board
1 - Mast	DA /TA (1)	(3)	X (2)	C	
2 - Shrouds intended for safety rigging parts: - Steel and fiber ropes - Terminal accessories	DA (1)	W	X (2)	C	
3 - Deck eyeplates, chain plate for safety rigging parts	DA (1)	(1)	X (2) (4)	C	
4 - Wind propulsion system accessories	DA (1)	W	X (2) (5)	W	
5 - Coupling bolts	DA (1)	C/W (6)	X	C / W (6)	
6 - Bearings	DA	W	X (2)	W	
7 - Slewing ring	DA	C	Xndt	C	
8 - Pedestal (not permanently connected to the hull)	DA	C	Xndt	C	
Rig Sail - Operating rigging parts (excluding drive unit)					(1) Approval as per Sec 3, [4.6] (2) Breaking test on specimen as per Sec 3, [4.6] (3) For welded construction. The extent and the nature of the non-destructive examinations are subject to the Society's agreement (4) Proof load as per Sec 3, [4.7]a) (5) Tests as per Sec 3, [4.3] (6) Tests as per Sec 3, [4.5] (7) Tests as per Sec 3, [4.7.1]b) (8) Tests as per Sec 3, [4.6]
1 - Ropes intended for operating rigging parts - Steel and fiber ropes -Terminal accessories	DA (1)	W	X (2)	W	
2 - Deck eyeplates, chain plate for operating rigging parts	DA (1)	W	X (3) (4)	W	
3 - Sheaves	DA (1)	W	X (3) (6)	W	
4 - Clutch, travelers and other operating rigging accessories	DA (1)	W	X (3) (7)	W	
5 - Wind propulsion system accessories	DA (1)	W	X (3) (8)	W	
6 - Winches and their accessories for operating rigging parts	DA (1)	W	X (5)	W	
7 - Slewing ring	DA	C	Xndt	C	



Item	Product certification				Remarks
	Design assessment / Approval	Raw material certificate	Examination and testing	Product certificate	
Rig Sail - Drive unit - Mechanical system (safety or operating rigging parts)					
1 - Winches for rotating and release systems	DA (1)	(2)	X (3) (4)	C	(1) Approval as per the present Rule Note (2) Material as per NR216 (3) For welded construction. The extent and the nature of the non-destructive examinations are subject to the Society's agreement (4) Running test as per agreed program (5) Electrical motors and equipment to be considered as intended 'for essential services'. Survey requirements as per NR266 item K (6) Material certificate of small pumps or valve required depending on the type of wind propulsion system. (7) Same considerations as for Pumps. See NR467 Pt.C, Ch.1, Sec.10, tab 41 (material certificates according to the piping class)
2 - Hydraulic systems and other component essential for the function of the winch		C	X	C	
3 - Motors and electrical equipment essential for the function of the winch (5)			X	C	
4 - Hydraulic accumulator	DA / TA	W / C	X h ndt	W / C	
5 - Hydraulic cylinders class I	DA / TA	C	X h ndt	C	
6 - Hydraulic motors / pumps belonging to class I and II	DA / TA	W / C (7)	X h ndt	C	
7 - Hydraulic motors / pumps belonging to class III			X h	W	
8 - Flexible hoses	TA	W	X h	C	
9 - Piping system and fittings		W / C (6)	X h ndt	W / C	
Rig Sail - Drive unit - Electrical system (safety or operating rigging parts)					
1 - Electric motors for essential functions of the wind propulsion system (1)	DA / TA		X	C / W	(1) Electrical motors and equipment to be considered as intended 'for essential services'. Survey requirements as per NR266 item K (2) As per NR467, Pt C, Ch3 (3) As per condition set in TA
2 - Cables, Circuit breakers, Contactors, Switch	TA			W / C (3)	
3 - Switchboard	DA		X	C	
4 - Control and monitoring system	DA / TA (2)		X	C / W (3)	





BUREAU VERITAS MARINE & OFFSHORE

Tour Alto
4 place des Saisons
92400 Courbevoie - France
+33 (0)1 55 24 70 00

marine-offshore.bureauveritas.com/rules-guidelines

© 2026 BUREAU VERITAS - All rights reserved



**BUREAU
VERITAS**

Shaping a World of Trust